



UNIVERSITÀ POLITECNICA DELLE MARCHE
Repository ISTITUZIONALE

Engineering knowledge formalization and proposition for informatics development towards a CAD-integrated DfX system for product design

This is the peer reviewed version of the following article:

Original

Engineering knowledge formalization and proposition for informatics development towards a CAD-integrated DfX system for product design / Favi, C.; Campi, F.; Germani, M.; Mandolini, M.. - In: ADVANCED ENGINEERING INFORMATICS. - ISSN 1474-0346. - 51:(2022). [10.1016/j.aei.2022.101537]

Availability:

This version is available at: 11566/296902 since: 2024-10-03T16:43:57Z

Publisher:

Published

DOI:10.1016/j.aei.2022.101537

Terms of use:

The terms and conditions for the reuse of this version of the manuscript are specified in the publishing policy. The use of copyrighted works requires the consent of the rights' holder (author or publisher). Works made available under a Creative Commons license or a Publisher's custom-made license can be used according to the terms and conditions contained therein. See editor's website for further information and terms and conditions.

This item was downloaded from IRIS Università Politecnica delle Marche (<https://iris.univpm.it>). When citing, please refer to the published version.

(Article begins on next page)

Title: Engineering knowledge formalization and proposition for informatics development towards a CAD-integrated DfX system for product design

Authors: Claudio Favi ^a, Federico Campi ^b, Michele Germani ^b, Marco Mandolini ^b

^a: Università degli Studi di Parma – Parco area delle scienze 181/A, 43121, Parma, Italy.

(claudio.favi@unipr.it)

^b: Università Politecnica delle Marche – via breccie bianche n. 12, 60121, Ancona, Italy.

(f.campi@univpm.it; m.germani@univpm.it; m.mandolini@univpm.it)

Corresponding author: Claudio Favi

(claudio.favi@unipr.it)

List of acronyms

<i>2D</i>	<i>Two dimensional</i>
<i>3D</i>	<i>Three dimensional</i>
<i>BOM</i>	<i>Bill of Materials</i>
<i>CAD</i>	<i>Computer Aided Design</i>
<i>CAPP</i>	<i>Computer-aided process planning</i>
<i>DB</i>	<i>Database</i>
<i>DfA</i>	<i>Design for Assembly</i>
<i>DfD</i>	<i>Design for Disassembly</i>
<i>DfM</i>	<i>Design for Manufacturing</i>
<i>DfX</i>	<i>Design for X</i>
<i>DfW</i>	<i>Design for Welding</i>
<i>GUI</i>	<i>Graphic User interface</i>
<i>KB</i>	<i>Knowledge Based</i>
<i>KPI</i>	<i>Key Performance Indicator</i>
<i>N.A.</i>	<i>Not Applicable</i>
<i>OWL</i>	<i>Ontology Web Language</i>
<i>PCB</i>	<i>Printed Circuit Board</i>
<i>PDP</i>	<i>Product Development Process</i>
<i>PMI</i>	<i>Product and Manufacturing Information</i>
<i>QFD</i>	<i>Quality Function Deployment</i>

Abstract:

Target design methodologies (DfX) were developed to cope with specific engineering design issues such as cost-effectiveness, manufacturability, assemblability, maintainability, among others. However, DfX methodologies are undergoing the lack of real integration with 3D CAD systems. Their principles are currently applied downstream of the 3D modelling by following the well-known rules available from the literature and engineers' know-how (tacit internal knowledge).

This paper provides a method to formalize complex DfX engineering knowledge into explicit knowledge that can be reused for Advanced Engineering Informatics to aid designers and engineers in developing mechanical products. This research work wants to define a general method (ontology) able to couple DfX design guidelines (engineering knowledge) with geometrical product features of a product 3D model (engineering parametric data). A common layer for all DfX methods (horizontal) and dedicated layers for each DfX method (vertical) allow creating the suitable ontology for the systematic collection of the DfX rules considering each target. Moreover, the proposed framework is the first step for developing (future work) a software tool to assist engineers and designers during product development (3D CAD modelling).

A design for assembly (DfA) case study shows how to collect assembly rules in the given framework. It demonstrates the applicability of the CAD-integrated DfX system in the mechanical design of a jig-crane. Several benefits are recognized: (i) systematic collection of DfA rules for informatics development, (ii) identification of assembly issues in the product development process, and (iii) reduction of effort and time during the design review.

Keywords:

DfX, CAD, Design guidelines, Design rules, Feature recognition, Engineering knowledge, Ontology.

1. Introduction

Product Development Process (PDP) is a consolidated engineering activity that takes a service or a product from conception to market. Product development includes a few steps: drafting the concept, creating the overall design, developing detailed design and prototyping. The first PDP stages consist of iterative steps to figure out conceptual solutions (idea generation). In contrast, the last steps concern more practical activities with recursive tasks (engineering design). The engineering design defines the complete set of product components specifications (geometry, materials, and tolerances) through detailed and general drawings, respectively, for parts and assemblies. One of the most recurring disciplines in the engineering design context relates to solid modelling and drawing. Since its birth, CAD (Computer-Aided Design) evolved from an electronic drawing board to a 3D solid modeller with parametric philosophy. Nowadays, CAD tools combine the initial capabilities for which they were conceived (e.g., to virtually create and visualize a part, verify the consistency of the final assembly and quickly realize a 2D engineering drawing) with the benefits deriving from the integration of the multidisciplinary design methodologies. During the time, CAD systems integrated different environments for specific aims, such as environmental assessment [Morbidoni et al., 2011; Tao et al., 2018], kinematic analysis [Lee and Chang, 2003; Komoto and Tomiyama, 2012] and ergonomic evaluation [Feyen et al., 2000; Marconi et al., 2018].

DfX is a general term used in the engineering community as a placeholder for design objectives. The particular "x" is the key to achieving success in the design phase. DfX provides a rule or a knowledge system where best practices related to the implementation of technical specifications allow engineers to comply with design requirements while developing a product. Based on the concepts represented by "x" (e.g., manufacturability, assembly, cost-effectiveness, reliability, maintainability, etc.), several guidelines were developed and collected in handbooks by the scientific communities or reside in the private repositories as part of the company's know-how (tacit internal knowledge). One of the main issues raised by academics and industry concerns disseminating this knowledge in technical departments and the possibility of having it when it is needed. This evidence highlights a gap in the state-of-the-art on CAD-integrated DfX methods and tools and opportunities to share engineering knowledge in the early product design phases (explicit knowledge). Integrating DfX techniques within computer-aided design software can reduce redesign and control activities which are knowledge-intensive engineering tasks. Based on the research gap illustrated above, the following research questions arise:

1. How can we make use of DfX guidelines for a software application?
2. Which type of information can be retrieved by analysing the 3D CAD model (i.e., type of feature to recognize, parameter to query) to develop a CAD-integrated DfX system and tool?

The paper addresses these two questions, providing a method that helps designers during the 3D modelling activities oriented to specific engineering objectives. This research aims to close the gap between the design and other engineering departments by creating a KB system (ontology) that translates tacit DfX knowledge into explicit and reusable knowledge applying an engineering informatics method. The analysis of a 3D CAD model allows anticipating engineering issues during the embodiment design phase. The investigation of 3D product features can provide valuable tips (feedback) about the implemented design choices in a given model with the possibility to assess KPIs (Key Performance Indicators) related to the specific objective. This work encompasses several engineering design topics such as knowledge formalization, design methodology, CAD modelling, feature recognition, and computer science, among others.

The novel contribution of this work consists of defining a methodological framework and knowledge representation that can be adopted to develop a CAD-integrated DfX tool (engineering informatics tool). This novelty deals with the current limitation observed in the scientific and industry literature reviews. The definition of a methodological framework is considered the starting point for developing a software tool to embed within a 3D CAD system. However, the CAD-integrated DfX software tool development is beyond the scope of this work.

After this introduction, the paper is structured as follows. Section 2 presents the literature analysis of related works about the same topic. Section 3 describes the overall methodology, including the DfX data collection, knowledge formalization (ontology definition) and link with geometric features retrieved by the analysis of the CAD model. Section 4 investigates the applicability of the given ontology for a specific objective: the DfA. Section 5 reports concluding remarks and future perspectives on this subject.

2. Research background

PDP is a long and iterative process for specific products. During the PDP, five main design activities are identified before the product release to the market: (i) problem definition and customer requirements, (ii) conceptual design, (iii) embodiment design, (iv) detailed design, and (v) prototyping. [Pahl et al., 2007] [Ulrich and Eppinger, 2011]. CAD tools are recognized as being reliable and efficient in the development of complex products during the early stages of product design (i.e. embodiment design and detail design). CAD tools allow designers to take advantage of the 3D product representation, switching from sketches to virtual models. Potentials of CAD tools are well-known in engineering activities covering a broad range of disciplines such as drawing, simulation, prototyping [Robertson and Radcliffe, 2009] [Chang, 2013]. Design for X (DfX) represents a suite of target-oriented design methodologies that aids designers while developing products, to solve specific engineering challenges (i.e., manufacturability, assemblability, maintainability, sustainability, and recyclability) [Benabdellah et al., 2019]. Despite the long history of DfX methods in engineering design, these methodologies suffer from the lack of real integration in terms of tools and computer-aided systems [Favi et al., 2018].

Preliminary attempts related to the definition of DfX tool were done at the end of '90s with the proposition of DfX shells [Huang and Mak, 1997; Huang and Mak, 1999]. The DfX shell concept was developed with the aim to apply a variety of DfX tools easily, quickly and consistently. The DfX shell exploits two concepts for product modelling: bill of materials (BOM) and key characteristics which are used to describe and analyse the overall product structure and features. Even if the design data represented in the mentioned documents provides a complete overview of the product information, the need for more pragmatic product data models suitable for DfX was mentioned, highlighting the possibility to develop devising data structures to support computer-aided design (CAD) systems. This limitation was tackled by the attempt to introduce more sophisticated data structures to support intelligent CAD systems, in terms of not only design data but also design knowledge. From those preliminary works related to DfX tools and their practical implementation into the product development process, two main research challenges emerged on this field. The first one concerns the knowledge formalization process which is a practice able to catch, collect, share, and reuse DfX rules and guidelines. Indeed, DfX is data intensive process and experience indicates that collecting appropriate data is a bottleneck in carrying out DfX analyses. The second one concerns the integration of DfX methods within available design tools (i.e., the CAD tool) where, currently, data is available in a complete and suitable form for engineering informatics. The integration allows

creating a smart and efficient system to check the consistency of the project with the DfX principles, with the aim to assist product designers during the design process.

In relation to the first challenge (DfX engineering knowledge formalization) a few attempts were proposed in literature through the adoption of a knowledge-based engineering system. The research applying knowledge-based systems to DfX methods can be divided into two main families: (i) the design knowledge management in DfX methodologies, and (ii) the definition of dedicated ontologies for specific design targets (e.g., DfM, DfA, etc.). Today, ontology-based knowledge processing is getting much attention for enhancing capability of product data management systems [Schmidt et al., 2020]. The concept of ontology allows representing knowledge over shared meta-data and to manipulate its contextual structure under the standpoint of computer engineering and apart from design engineering. The use of ontology in informatics enables for a more interoperable and thorough management of a significant amount of knowledge across multiple domains, tasks, and disciplines. An interesting research work about the design knowledge management in DfX methodologies was presented by Nomaguchi and Fujita [Nomaguchi and Fujita, 2007] which debate the contrast between DfX methodologies and knowledge-based design support systems. The paper experimentally implemented a prototype system (ontology) in an object-oriented language, based on a QFD-based cost-worth analysis. The example demonstrated that the QFD structure and the proposed ontology characterized by layers are appropriate for building a knowledge-based design support system; however, the data management is a limitation as well the adaptability of this approach for large-scale projects as compared with practice. Another work proposed by Faerber et al., [Faerber et al., 2008] tried to expand the concept of a multidimensional process-oriented knowledge management system by integrating two separate models for the DfX structuring: (i) a process model which describes the development process itself, the dependencies between work steps and documents produced, and (ii) a knowledge model which describes the context and best practices that can be used while working on a certain process step. These two models can be integrated into a single data model deriving an ontology for the process based storage of DfX criteria. Concerning specific design targets (e.g., DfM, DfA, DfD, etc.), more research works are available about the definition of dedicated ontologies. DfM and DfA, among others, were the most debating target design methodologies where the use of ontologies for knowledge formalization process was adopted [Yang et al., 2008] [Chang et al., 2010] [Debord et al., 2018] [Li et al., 2018] [Ahmad et al., 2018] [Poorkiany et al., 2016] [Chhim et al., 2019]. Molcho et al. proposed one of the most promising works on this subject, focusing on a feature-based analysis system able to capture diverse DfM know-how in a structured manner [Molcho et al., 2008]. DfM knowledge formalization was largely debated in the literature and the collection of manufacturing knowledge to improve product design is a well-addressed topic. However, the possibility to have a general framework for DfX methods rules collection and formalization is still a grey area with potential for research activities.

In relation to the second challenge (CAD-integrated DfX methods) the literature provided only dedicated examples referring to a specific target (e.g., manufacturing, assembly, disassembly, etc.). To the best of the authors' knowledge, a synthesis allowing to switch from the dedicated target (i.e., CAD-integrated design for metal stamping, CAD-integrated design for welding) to multiple targets is currently missing. Manufacturability and assemblability were firstly addressed by the scholars exploring the application of feature-based representation to incorporate the tooling and technology considerations into the early stages of design [Mantripragada et al., 1996] [Chen et al., 1998]. Parts created by CAD system are represented by features that are easily linked with manufacturing features and operations (i.e., CAM and CAPP) [Ma et al., 2018] [Campi et al., 2019]. On this aim, ontological relations between DfM principles and the necessary interpretation of the virtual model available by the CAD were addressed [Heeranand et al., 2017] [Gembariski, 2020]. The developed tools allow the analysis of CAD models, integrating DfM principles which contribute to manufacturing time and rework reduction. Commercially available solutions were developed on the given methods, i.e. the Calibre DFM

software tool able to support electronic engineering in the development of manufacturing compliant print circuit board (PCB), as well as DFMPPro® which focus is the design of mechanical components in compliance with the traditional technology processes (e.g., machining, stamping, metal casting, etc.) [DFMPRO, 2020]. At a later time compared with manufacturing and assembly, disassembly was also investigated through the means of feature-based approach, trying to couple DfD principles and feature data extracted from CAD models. Data necessary for DfD analysis and retrieved by the CAD models is not only related to the product features, but concerns the direction of extraction, the adoption of specific tool, accessibility and so on [Desai and Mital, 2005] [Favi et al., 2019]. Feature-based approach for life cycle analysis and environmental concerns were studied with the aim to link CAD feature with LCA methodology encouraging the use of CAD models for the life cycle inventory phase which is time consuming and prone to error [Morbidoni et al., 2011] [Tao et al., 2017]. The same approach based on feature analysis from CAD models was also investigated in the context of ergonomics assessment to implement design for ergonomics tools [Marconi et al., 2018]. Among the several systems proposed for design for ergonomics, to cite a few CAD-based tool were developed on this aim and commercially available (i.e., DELMIA by Dassault Systemes) enabling the evaluation of workplace and product designs through 3D environment.

The feature-based approach which is the backbone theory of the developed methods seems promising in the development of the CAD-integrated DfX method but a complete framework is necessary to tackle the peculiarities of different DfX methods. In all the mentioned systems and tools, feature extraction from a 3D solid model is a fundamental task in the integration of DfX rules within the design process due to the possibility to check design constraints when design changes are made.

3. Materials and Method

Intending to integrate the DfX approach within the 3D CAD modelling, this section describes the materials and methods used for this purpose. The CAD-integrated DfX method concerns the following aspects: the methodological framework (section 3.1) and the knowledge-based (KB) system (section 3.2).

3.1 Methodological framework

The framework proposed in this research is the ontology used to collect and represent knowledge referring to DfX methodologies. An ontology (i.e. structuring and formalization of data into hierarchies and classes to establish the relations between the data required for efficient machine processing) allows to define DfX guidelines for software application and provides a comprehensive description of the domain of interest (DfX rules). In this case, the proposed ontology consists of a horizontal layer that is common and consistent across all DfX methodologies, as well as a collection of vertical layers (n-layers), one for each design objective and capable of representing various design methodologies (Figure 1). When a new design methodology is integrated into this framework, the arrangement of new concepts is required only in the vertical layer. The ontology is the means that provides the semantic (logic) used to switch from tacit knowledge (unstructured) to explicit knowledge (structured).

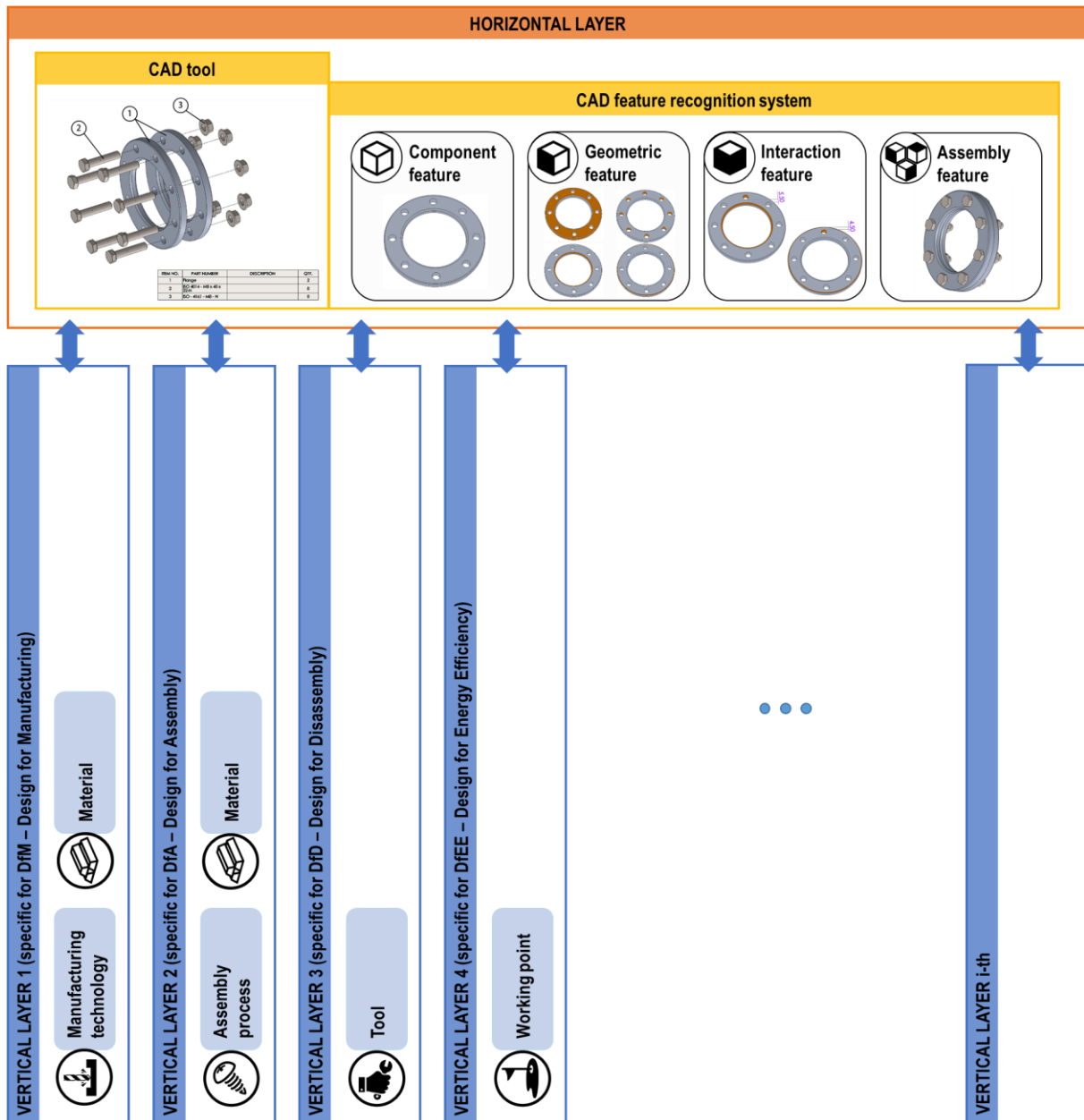

Figure 1: methodological framework of the CAD-integrated DfX system

It is well known that DfX approaches focus on specific stages of product lifecycle or a particular aspect of products or processes. This fact makes holistic product design optimization highly complex. For this reason, in the proposed framework, each set of rules for a specific design objective is developed independently of the others.

The horizontal layer contains sets of data retrieved by the CAD model under development and required to characterize a DfX rule. This layer is common among the several types of objectives the user wants to account for. The first set of data concerns features of every single component of the assembly (i.e., component feature, geometric feature and interaction feature) and associated parameters. The second data set involves the features related to the overall assembly (i.e., assembly feature), components' spatial distribution, and their relations. The use of feature recognition methods allows extracting features from a 3D CAD model. A feature recognition process begins by defining the types of features to be identified. Up to now, a common and standardized methodology for feature classification is still missing because it depends on the

application scenario [Sanfilippo and Borgo, 2016]. The same authors provided a 3D CAD features classification according to the specific objective of welded assemblies – Design for Welding [Favi et al., 2021]. A more broad and complete classification is provided in this work, and Figure 2 illustrates the types of features used in this research and their relationships:

- *Component feature*: this is a feature used to represent components (e.g., screw, nut shaft) [Staub et al., 2003]. It describes the most relevant characteristics of a component, such as material (i.e., material feature), mass, volume and area. There is only one feature for each component;
- *Geometric feature*: this is a specific form feature (i.e., a feature that embodies elements characterized via shape properties) used for representing manufacturing features (e.g., step, slot, pocket, hole, pad, chamfer, fillet, etc.) through its type, list of faces, list of properties, volume, etc. [Sanfilippo and Borgo, 2016]. There is one or many features for each component;
- *Interaction feature*: this is a feature (definition rearranged from [Nasr 2006]) determined by the interaction of two or multiple geometric features (e.g., the distance between a slot and a hole). It describes the relationships (e.g., distance, overlapping) between adjacent features. There could be none or multiple interaction features for each component. Each interaction feature is made of two or many geometric features
- *Assembly feature*: this is a specific kind of form feature that is functional to assemble different components (e.g., screw/hole, belt/pulley) through its type (simple contact, treaded, welded, snap-fit, adhesive bonding, riveting, electrical, etc.), list of components that belongs to the assembly type, list of removal direction in different axis or paths (e.g. X-direction, Y-direction, Z-direction, axial rotation), list of properties, etc. [Sanfilippo and Borgo, 2016]. There is at least one feature for each assembly that join two or multiple components.

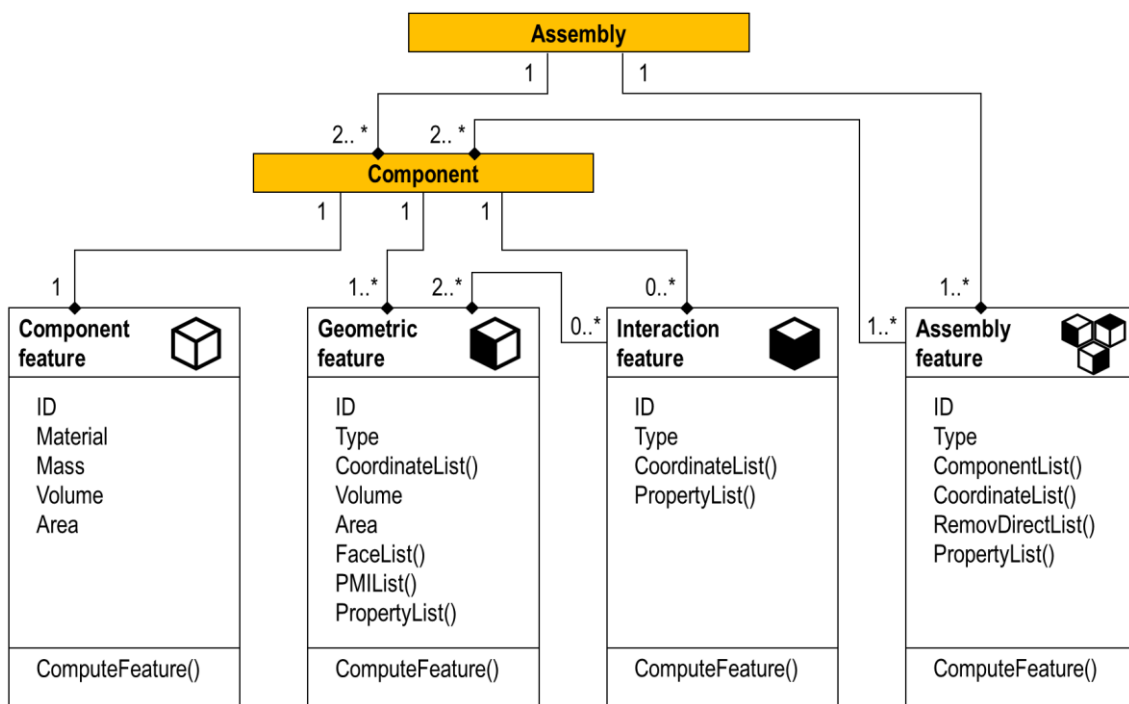

Figure 2: Feature recognition framework (Class Diagram).

Component features are usually available by querying the 3D geometry (B-rep model – boundary representation) because attributes included in this class are readily accessible. Geometric, interaction, and assembly features can be extracted from a 3D model using specific software tools for geometric feature recognition (e.g., SolidWorks feature recognition tool by

Dassault Systemes). Following the OWL (ontology web language) representation, the proposed ontology for geometric features and parameters dataset is shown (as an excerpt) in Figure 3, including the relationships among the identified features concepts.

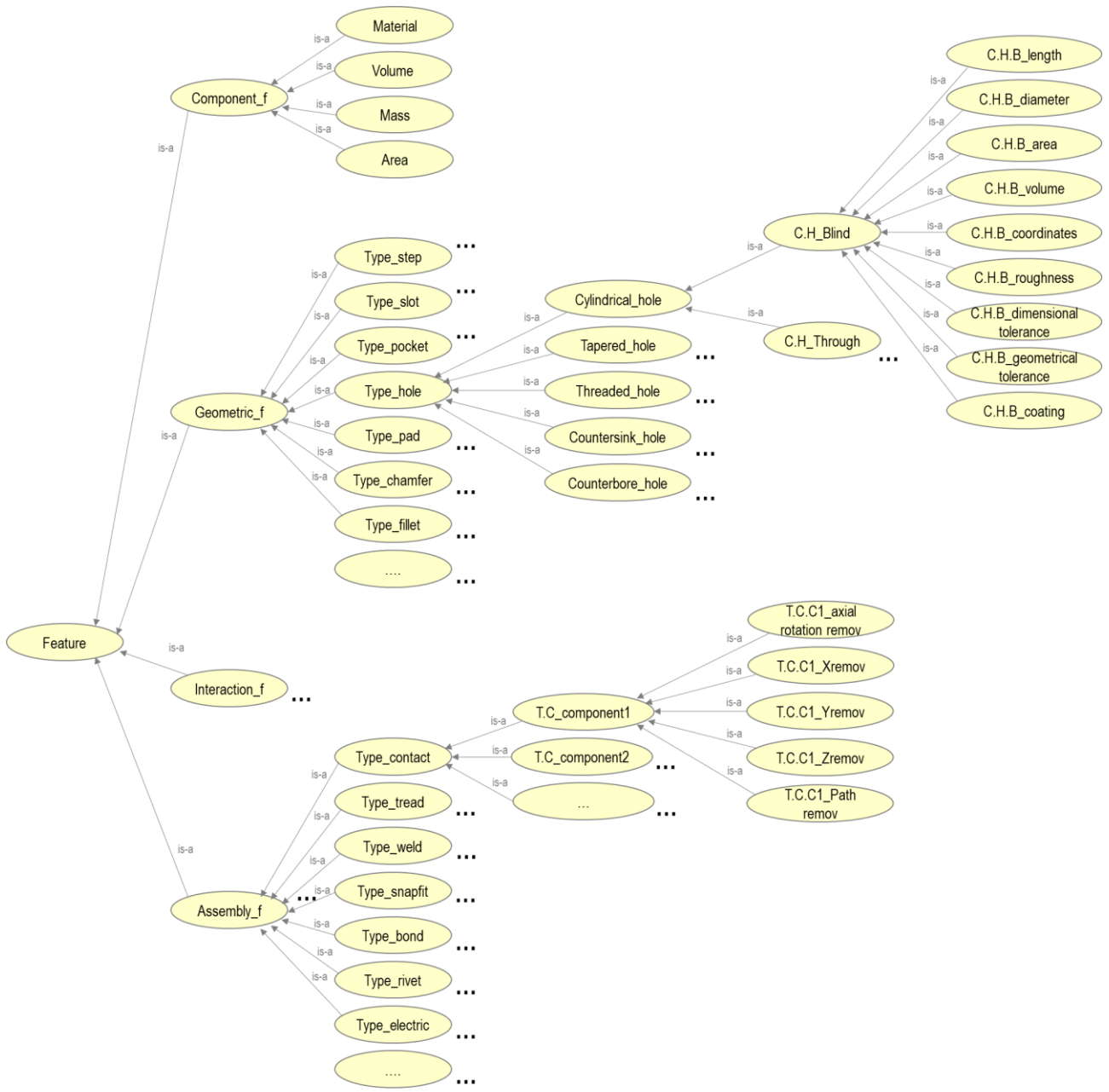

Figure 3: OWL representation (excerpt) for the horizontal layer

To figure out the structure of the given ontology, an example is reported here below. Let's consider a DfX rule which concerns the diameter size for a blind hole (i.e., a Design for Manufacturing and Assembly rule that concerns the standard size of hole diameter, or a Design for Hygienic rule that concerns the required minimum hole diameter for cleaning tool accessibility). In this case, the feature recognition system starts the 3D CAD model analysis querying the geometric feature (Geometric_f) and analyzing the hole type among all the geometric features (Type_hole). Then, depending on whether the specific rule concerns only cylindrical holes, this subset is considered (Cylindrical_hole), while if the rule concerns cylindrical holes and tapered holes, both are considered (Cylindrical_hole AND Tapered_hole). Finally, the subset blind hole is considered (C.H_Blind) and the hole size parameter is analysed (C.H.B_diameter).

Every vertical layer contains a specific set of data necessary to characterize the rules in its specific framework (X - objective), and each layer is objective-dependent. Several domains can be defined in each layer based on the characteristics of the target. As reported in Figure 1, if the focus concerns the Design for Manufacturing, two clusters (domains) are necessary to correctly represent the knowledge associated with this framework (i.e., Manufacturing technology and Material domains). In contrast, if the focus concerns the Design for Disassembly, one cluster is enough to correctly represent the knowledge associated with this framework (i.e., Tool domain). The same knowledge formalization process (ontology) is adopted to collect and describe the knowledge inside each domain. For brevity, this section reports only the ontological representation of the domain “Tool” for the vertical layer “Design for Disassembly”, following the OWL representation (Figure 4).

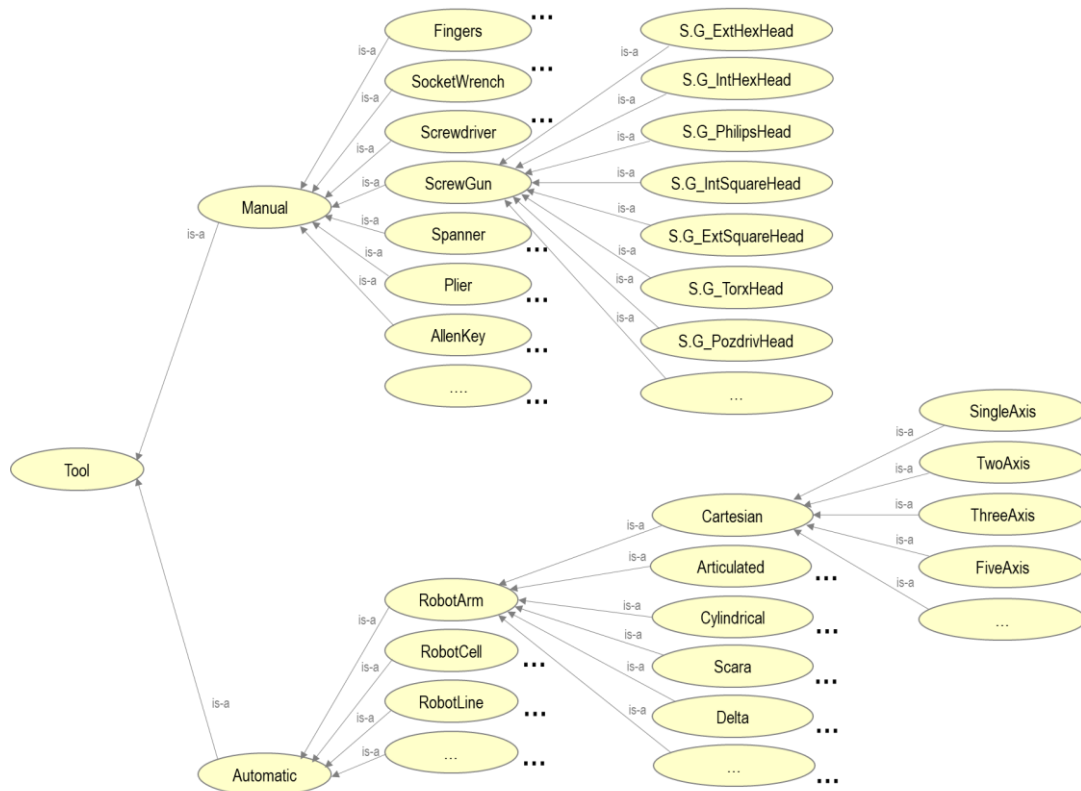

Figure 4: OWL representation (excerpt) for the vertical layer related to DfD – Tool domain

Each vertical layer requires the definition domains and the ontology representation necessary to characterize the domain itself.

3.2 KB system

Design for X refers to using a formal methodology to optimize a specific aspect of a product. Because these approaches provide qualitative design guidelines for a particular product lifecycle stage (e.g. Design for Manufacturing, Design for End-of-life) or a general property/virtue which is not strictly related to the product life cycle (e.g. Design for Environment, Design for Hygienic), this knowledge requires a formalization by adopting a KB system. The design guidelines usually propose an approach and corresponding methods to help engineers generate and apply technical knowledge to control, improve, or even invent particular product characteristics. The way to translate a DfX guideline (usually available in written form) into a formalized one (usually described with a list of attributes and numerical parameters) requires adopting

a KB system. The KB system used for this process is presented below, and it is grounded on three main pillars: (i) *knowledge acquisition*, (ii) *knowledge processing*, and (iii) *knowledge representation*.

Knowledge acquisition concerns the review of technical documents (handbooks, reports, thesis) and the acquisition of industry best practices for collecting design rules in each domain of interest (based on the target of DfX). Technical documents present the crystallization of knowledge that evolved over a long period of time and contain domain-specific data. This knowledge and related data are usually available in very general forms. Industry best practices (field data, experiments, etc.) are usually available in a large volume, even if these data generally require careful processing before the use. The knowledge acquisition phase consists in collecting unstructured design rules (i.e., sentences, equations, etc.) to create a list of rules for each DfX environment. In this step, the most considerable amount of guidelines is expected to be collected. Following the literature analysis, forty-one DfX approaches were analysed, and more than one thousand different qualitative design guidelines were found [Dombrowski et al., 2014]. Table 1 reports an overview of the main DfX methods and their classification. DfX methods are classified according to the analysis scope: product and system [Chiu and Okudan 2010] [Benabdellah et al. 2019]. In this work, only the DfX methods belonging to the product scope are considered. For this group of methods, a deeper classification is provided based on the topic (i.e., lifecycle and specific property/virtue) [Holt and Barnes 2009] [Dombrowski et al., 2014]. The topic lifecycle can be further classified into three main phases: material & manufacturing, use, and end-of-life.

Table 1: an overview of DfX methods and classification

Scope	Topic	Phase	Target (X)	Aim	KPI
Product	Lifecycle	Material & Manufacturing	Design for Assembly (DfA)	Design to reduce the number of parts, assembly tasks including handling, insertion and fixation; design to reduce the process complexity	Economic
			Design for Manufacturing (DfM)	Design to avoid unfeasible manufacturing processes and to reduce expensive manufacturing processes and materials	Economic
			Design for Manufacturing and Assembly (DfMA)	Design to address both DFM and DFA	Economic
			Design for Chipping (DfChip)	Design to avoid unfeasible chipping tasks and to reduce expensive chipping processes and materials	Economic
			Design for Welding (DfW)	Design to avoid unfeasible welding tasks and to reduce expensive welding processes and materials	Economic
			Design for Casting (DfCast)	Design to avoid unfeasible casting tasks and to reduce expensive casting processes and materials	Economic
			Design for Additive Manufacturing (DfAM)	Design to avoid unfeasible AM tasks and to reduce expensive AM processes and materials	Economic
			Design for Forming (DfF)	Design to avoid unfeasible forming tasks and to reduce expensive forming processes and materials	Economic
			Design for Material selection (DfMat)	Design to select the most suitable and cost-efficient material	Economic
			Design for Manufacturing process selection (DfMan)	Design to select the most suitable and cost-efficient manufacturing process and production economies	Economic
			Design to Cost (DfC)	Design to reduce the overall product cost	Economic

			Design for Tollerancing (DfT)	Design to the selection of specifications for individual components using formal optimization	Economic
			Design for Packaging (DfPack)	Design to reduce the amount and the costs of packaging	Economic
		Use	Design for Energy Efficiency (DfEE)	Design to reduce energy loss and to increase the overall energy efficiency for energy-related products	Economic Environmental
			Design for Maintenance Design for Maintainability (DfMaint)	Design to simplify the maintenance process for scheduled and failure maintenance: design to reduce repair time and to improve fault isolation	Economic Environmental
			Design for Service (DfS)	Improving the capability of installation, commissioning, and maintenance through design	Economic
			Design for Reliability Design for Failure Design for Obsolescence (DfRel)	Design reliability into products. Both hardware and software reliability should be considered.	Economic
		End-of-life	Design for End-of-life (DfEoL)	Design to reduce the environmental impact of products at the end-of-life, including easy disassembly, and the adoption of circular economies	Environmental
			Design for Circular Economy (DfCE)	Design to favour the adoption of circular economies (reuse, remanufacturing, repair, recycling, refurbishment, etc.)	Environmental
			Design for Disassembly (DfD)	Design to ensure easy access to fasteners and joints and to lower destructiveness and selectiveness of the disassembly process	Economic Environmental
			Design for Reuse (DfReuse)	Design to standardize components and to enhance the durability of reuse targeted components	Economic Environmental
			Design for Remanufacturing (DfReman)	Design to enable product remanufacturing, including disassembly, assembly, cleaning, testing, repair, and replacement	Economic Environmental
			Design for Repairability (DfRepair)	Design to simplify the repairability process, including disassembly time, cost of spare parts and availability of spare parts	Economic Environmental
			Design for Recycling (DfRecycle)	Design to increase recyclable material in the development of product components as well as to minimize material variety to increase recycling efficiency and separation	Environmental
			Design for Repurposing Design for Refurbishment (DfRep)	Design a product with qualities, features and details that facilitate repurposing and refurbishment	Economic Environmental
	Property/Virtue		Design for Quality (DfQ)	Design to eliminate defects in production processes and to meet customers' requirements	Economic
			Design for Ergonomics (DfErg)	Design the piece and the workplace to fit the needs of the worker during its activity for reducing the physiological and biomechanical stresses on the seated body	Economic Social
			Design for Environment (DfE)	Design to consider environmental concerns, safety and health.	Environmental
			Design for Sustainability (DfSust)	Design to consider the three dimensions of sustainability: economy, ecology, and equity	Economic Environmental Social
			Design for Lifecycle (DfLC)	Design to reduce life cycle cost and environmental concerns	Economic Environmental

			Design for User-Friendliness (DfUF)	Design to ensure that the product interface has elements that are easy to access, intuitive and responsive	Social
			Design for Safety (DfSafe)	Designing to eliminate or reduce risks in the final product or its operation involving safety	Economic Social
			Design for Hygienic (DfH)	Design to minimize contamination risk and enable effective cleaning and sanitation in the food, pharma, chemical and cosmetic fields	Economic Social
			Design for Variety (DfV)	Design to reduce design effort and time to market and to reduce the impact of cost producing product variations	Economic
			Design for Modularity (DfMod)	Design to have loosely coupled interfaces enabling module variation in products	Economic
			Design for Regulatory Compliance (DfRC)	Ensure that the design meets all regulatory requirements, including technical, safety, materials and environmental requirements	Economic Environmental
System			Design for Supply Chain (DfSC)	Design to improve the supply chain efficiency, inventory turn-over and reduce lead times. Design for high assembly and manufacturing efficiency. Design to improve the logistics efficiency, reduce the cost for product logistics (packaging, transport, etc.)	Economic
			Design for Logistics (DfL)	Design to decrease time and cost for storage and transportation of products and components	Economic
			Design for Reverse Logistics (DfRL)	Design to enable customers to support preventing returns of products and to facilitate the collection of end-of-life products	Economic
			Design for Six Sigma (DfSS)	Design to reduce variation and defects; design to meet customers' requirements	Economic
			Design for Procurement (DfProc)	Design the product to ensure multiple sources of supply are identified for all components where possible. Perform risk assessments on single-source items and long lead time items. Reduce components number and system complexity to minimize the product and maintenance cost while improving the reliability of the product	Economic
			Design for Waste Minimization (DfWM)	Design to reduce waste; design to increase the use of biodegradable materials	Economic Environmental

Knowledge processing concerns translating DfX design rules previously collected during the knowledge acquisition phase into a structured repository based on the proposed framework (ontology). This phase consists of the identification of CAD features and numerical parameters (the ones referring to the horizontal layer) linked with the design rules (numerical data), as well as other necessary attributes (the ones referring to the domains inside a vertical layer). This task is essential to translate the tacit knowledge (DfX rules list) into explicit knowledge used for informatics development. The form required to develop a DfX rule for informatics development is a checklist or equation, which indicates compliance (validated) or violation (non-validated). The repository stores a list of rules (univocally determined by an integer number) with the importance (i.e., info, warning, critical). Besides these two items, which are metadata, the structure is composed of several tables. The table related to the horizontal layer deals with the geometrical parameters and thresholds described within the design rule (Table 2). Five items are included in this table: (i) feature type (component feature, geometric feature, interaction feature, and assembly feature), (ii) 3D CAD feature/s to identify (e.g., hole, slot, pocket, etc.), (iii) PMI – Product Manufacturing Information to read (e.g., roughness, linear tolerance, geometrical tolerance, etc.), (iv) parameter/s (i.e., dimension) to verify, and (v) threshold to respect. Indeed, to verify if a given rule is violated or not by

analysing a CAD model, a numerical rule (i.e., a pocket with internal radius $\neq 0$) or a threshold (i.e., hole diameter $\leq 3\text{mm}$) is necessary.

Table 2: list of data required in the horizontal layer to define a DfX rule and two examples

Rule #	Rule type	CAD features and algorithms				
		Feature type	CAD features to identify	PMI to read	Parameters	Parameter or threshold to verify
1	Warning	Geometric feature	Hole	Ra = hole roughness	hole diameter (D) hole length (L)	$Ra \leq 0,8 \mu\text{m}$ $L/D \geq 5$
2	Warning	Interaction feature	Bend Hole Slot	N.A.	bend radius (r) sheet metal thickness (t) distance between bend and hole/slot edge (D)	$D \leq r + 4t$
...						

The other tables related to the vertical layer deal with the frame of interest (the target to analyse). They are built following the necessary attributes to consider in each domain. In this case, the list of data is target-dependent and varies based on the domain under consideration.

Knowledge representation concerns the fulfilment of the repository that encompasses the logical definition of DfX design guidelines (syntax) and related information (e.g., suggestions about design changes). Indeed, a taxonomy and a syntax are necessary to keep consistency among different guidelines and provide the same level of details and information that a designer can manipulate during the product development process. DfX guidelines syntax requires necessary and optional information. Essential information is the minimum set of data required to define a design guideline. This set of data includes: (i) the design action to do (verb), and (ii) the subject which requires modification (name). Optional information is an additional set of data that clarifies the context in which the design action is needed. It is worth noting that in the knowledge representation phase, KPIs can be adopted to quantify the gap between a wrong and a correct design solution [Favi et al., 2016] [Campi et al., 2020]. KPIs allow estimating the benefit introduced by the application of a design guideline, quantitatively supporting the design changes. KPIs need to be defined in the given frame of the target to optimize by the design. Usually, the cost is one of the most significant and understandable indicators to implement among the DfX methods. However, other KPIs (e.g., time, emissions, etc.) can be more suitable considering a specific target.

4. Case study

This section presents a case study focused on design for assembly (DfA) concerning the proposed framework. As reported in Figure 1, two clusters (domains) are necessary to correctly represent the knowledge associated with this framework: Assembly technology and Material domains. Assembly technology is related to the technological aspects of a given rule. It includes two sub-clusters: (i) assembly technology class and (ii) assembly technology type.

Class defines the different methods of assembly that could be found [Mital et al., 2015]:

- *Manual assembly*: Manual assembly is a process characterized by operations performed manually, with or without the aid of simple, general-purpose tools, such as screwdrivers and pliers. Although this method is versatile and requires little initial investment, there is usually an upper limit to the production volume, and labour

costs are higher (including benefits, worker's compensation due to fatigue and injury, and overhead for maintaining a clean and healthy environment).

- *Automatic assembly*: Automatic assembly uses synchronous indexing machines and part feeders or nonsynchronous machines, where a free transfer device handles parts. The system is generally built for a single product, and the cost per unit decreases with increasing production volume.
- *Fixed or hard automation*: Fixed or hard automation are used for large volume productions and is characterized by a custom-built machine that assembles only one specific product and entails a significant capital investment. Indexing tables, parts feeders, and automatic controls typify this inherently rigid assembly method.
- *Robotic assembly* (soft automatic assembly): This form is best suited for those products whose production volume lies between manual and automated assembly methods. It can be composed of a single robot or a multi-station robotic assembly cell. All activities are simultaneously controlled and coordinated by a programmable logic controller or computer. Although this assembly method can have significant capital costs, its flexibility often helps offset the expense across many different products.

The adoption of these clusters is necessary to classify DfA rules that are generic for an assembly class or specific for an assembly operation. Indeed, a DfA rule may be valid for the generic assembly process class (e.g., manual assembly) regardless of the particular operation (e.g., fastening, riveting). Conversely, an assembly rule may be valid only for a specific operation (e.g., fastening) and cannot be generalized for the assembly process class that contains the operation (e.g., manual assembly). Figure 5 represents the OWL representation for the vertical layer related to DfA – assembly process domain.

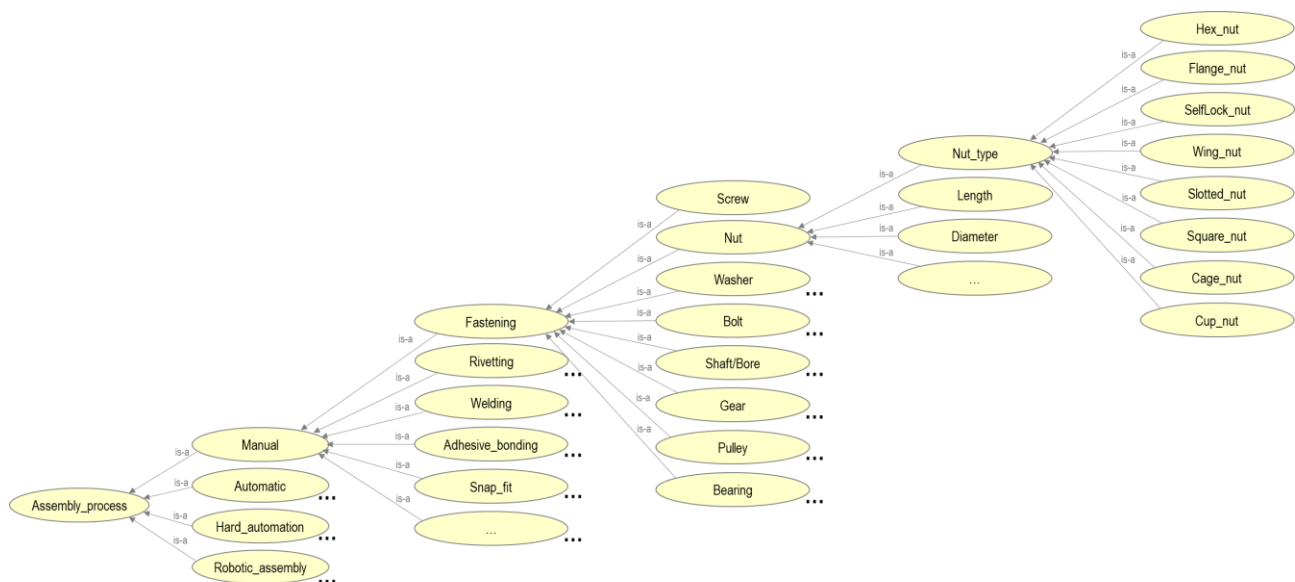

Figure 5: OWL representation (excerpt) for the vertical layer related to DfA – Assembly process domain

Material domain requires the definition of two clusters according to Ashby [Ashby, 2010]: (i) material class and (ii) material type. These two groups allocate a given DfA rule to a generic class (e.g., carbon steel) or a specific material type (e.g., C40). The identification of these two clusters allows classifying DfA rules that are valid for any material (N.A. – Not Applicable), for a given material class (e.g., stainless steel) or for a given material type (e.g., AISI 304).

The proposed ontology, according to the KB system presented in the methodological section was used to collect a list of DfA rules. Each rule was retrieved by analysing the literature in this field and involving several manufacturing companies in this project. An overview (excerpt) of the DfA rules collected using the given ontology is reported in Appendix B. The overall number of DfA rules collected within this work is 74. As presented in the previous section, the horizontal layer requires the following items for a rule classification: (i) two metadata (i.e., rule number and rule type), and (ii) five data related to CAD features and algorithms (i.e., feature type, CAD features to identify, PMI to read, parameters, and parameter or threshold to verify). On the other hand, the DfA vertical layer requires the following items: (i) assembly process (i.e., class and type-level), and (ii) material (class and type). For the assembly process is possible to identify more than one level for the type if needed. For the sake of completeness, the written form of the DfA guideline is reported with a specific syntax (i.e., action + subject + adjective and context) for each guideline.

By following the presented ontology, the proposed framework was used to collect DfA rules for product assembly in the field of mechanical assemblies. The case study used to perform the DfA analysis is a jib crane made of 91 components (parts), three sub-assemblies (arm.stp, column.stp and pivot wall.stp) and one product (jib-crane.stp). Figure 6 shows the exploded view of the jib crane in its original design.

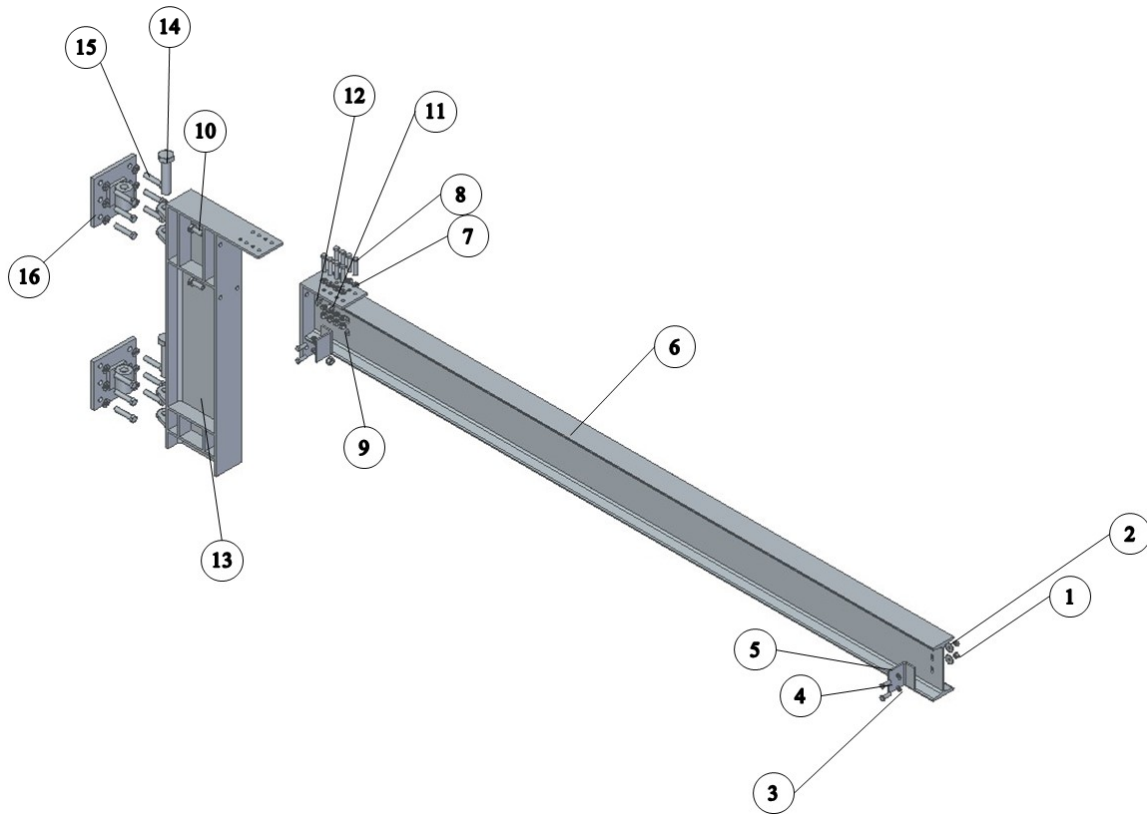

Figure 6: Exploded view of the case study (original design)

The list of components, quantities and materials are reported in the BOM of Table 3

Table 3: Bill of materials of the case study (original design)

No.	Component	Quantity	Material
1	Hex nut ISO 4034 M10.stp	4	39NiCrMo3
2	Plain washer Xlarge ISO 7094 M10.stp	4	AISI 316
3	Plain washer ISO 7089 M10.stp	4	AISI 316
4	Hex head screw ISO 4016 M10 x 35.stp	4	39NiCrMo3

5	Stopper.stp	2	AISI 316
6	Arm.stp	1	S275 JR
7	Plain washer ISO 7089 M12.stp	16	AISI 316
8	Hex head screw ISO 4018 M12 x 60.stp	8	39NiCrMo3
9	Hex nut ISO 7417 M12.stp	8	39NiCrMo3
10	Hex head screw ISO 4012 M16 x 45.stp	4	39NiCrMo3
11	Plain washer ISO 7089 M16.stp	16	AISI 316
12	Hex nut ISO 4034 M16.stp	4	39NiCrMo3
13	Column.stp	1	S275 JR
14	Hex head screw ISO 7412 M30 x 140.stp	2	39NiCrMo3
15	Hex head screw ISO 4018 M16 x 80.stp	12	39NiCrMo3
16	Pivot wall.stp	1	S275 JR

It is worth noting that the case study focuses only on mechanical assembly (DfA). The design for manufacturing (DfM) of the parts and design for welding (DfW) of the sub-assembly's components 6 (Arm.stp), 13 (Column.stp) and 16 (Pivot wall.stp) are out of scope. The CAD-integrated DfA method proposed in this example started with the 3D model data reading. Features were extracted and analysed concerning the features identified in the proposed framework to characterize the DfA rules. It's worth mentioning that the feature extraction was done manually by the authors of the paper for the purposes of this exercise, without using a software tool. An example of the component, geometric and interaction features recognized from the Column.stp component is provided in Appendix A (Table 6). Appendix A (Table 7) presents the assembly features identified for the jib crane assembly in the original design. Once the CAD feature recognition system has read the features and parameters, these are compared against the corresponding ones stored in the DfA rules DB (Appendix B). The DfA rules DB is the repository collecting all the DfA design guidelines according to the given ontology. Among all the rules available in the database, only a subset is considered applicable for the case study based on the selected assembly class (i.e., manual assembly) and assembly type (i.e., fastening). The user is usually in charge of specifying the assembly class and type. By following the analysis of the 3D model feature versus the DfA rules belonging to this subset, it is possible to identify validated and non-validated rules. A validated rule means that all the features of the CAD model comply with the subset of the rules. In contrast, a non-validated rule means that there is at least one feature of the CAD model that does not meet the requirement provided by the rules subset. The parameter or the threshold to verify is the trigger that identifies validated and non-validated rules (i.e., the model's compliance with the target of the DfX method).

Concerning the rules analysis phase of the jib-crane, seven design issues (non-validated rules) related to the manual fastening assembly are identified and summarized in Table 4.

Table 4: non-validated rules and involved features for the jib-crane example

Rule #	Assembly issue	Component/assembly name	Features involved
7	Guarantee flat surfaces for the insertion holes for screws in the assembly process of bolted components	→ Jib crane.stp (Column.stp vs. Arm.stp vs. Hex head screw ISO 4018 M12 x 60.stp vs. Plain washer ISO 7089 M12.stp vs. Hex nut ISO 7417 M12.stp)	→ Assembly features: → Feature_1 - HOLE RECTANGULAR PATTERN (Column), Feature_1 - HOLE RECTANGULAR PATTERN (Arm), Feature_1 - CYLINDRICAL PAD (Hex head screw ISO 4018 M12 x 60), Feature_1 - CYLINDRICAL HOLE (Plain washer ISO 7089 M12) and Feature_1 - CYLINDRICAL HOLE (Hex nut ISO 7417 M12).

8	Guarantee minimum distance between the axis of two or more screws in the manual assembly process of bolted components	→ Jib crane.stp (Column.stp vs. Arm.stp vs. Hex head screw ISO 4018 M12 x 60.stp vs. Plain washer ISO 7089 M12.stp vs. Hex nut ISO 7417 M12.stp)	→ Assembly features: → Feature_1 - HOLE RECTANGULAR PATTERN (Column), Feature_1 - HOLE RECTANGULAR PATTERN (Arm), Feature_1 – CYLINDRICAL PAD (Hex head screw ISO 4018 M12 x 60), Feature_1 – CYLINDRICAL HOLE (Plain washer ISO 7089 M12) and Feature_1 – CYLINDRICAL HOLE (Hex nut ISO 7417 M12).
6	Prefer the use of combined fasteners in the manual assembly process of bolted components	→ Jib crane.stp (Hex nut ISO 4034 M10.stp, Plain washer Xlarge ISO 7094 M10.stp, Plain washer ISO 7089 M10.stp, Hex head screw ISO 4016 M10 x 35.stp)	→ Assembly features: → Hex nut ISO 4034 M10, Plain washer Xlarge ISO 7094 M10, plain washer ISO 7089 M10 and Hex head screw ISO 4016 M10 x 35 in the connection between Stopper (5) and Arm (6). → Plain washer ISO 7089 M12, Hex head screw ISO 4018 M12 x 60 and Hex nut ISO 7417 M12 in the connection between packing Column (13) and Arm (6). → Hex head screw ISO 4012 M16 x 45, plain washer ISO 7089 M16 and Hex nut ISO 4034 M16 in the connection between Column (13) and Arm (6). → Hex head screw ISO 7412 M30 x 140 and hex head screw ISO 4018 M16 x 80 in the connection between Pivot wall (16) and wall.
25	Guarantee the minimum distance between screw hole and component edge in bolted/riveted assembly	→ Column.stp	→ Interaction features: → Feature_1 – HOLE RECTANGULAR PATTERN (Column) and Feature_2 – RECTANGULAR PAD (Column)
3	Keep aligned screw, nut and hole axis in the manual assembly process of bolted components	→ Jib crane.stp (Column.stp vs. Arm.stp vs. Plain washer ISO 7089 M12.stp vs. Hex head screw ISO 4018 M12 x 60.stp vs. Hex nut ISO 7417 M12.stp and Column.stp vs. Arm.stp vs. Plain washer ISO 7089 M16 vs. Hex head screw ISO 4012 M16 x 45 vs. Hex nut ISO 7417 M16)	→ Assembly features: → Feature_1 – HOLE RECTANGULAR PATTERN (Column), Feature_1 - HOLE RECTANGULAR PATTERN (Arm), Feature_1 – CYLINDRICAL PAD (Hex head screw ISO 4018 M12 x 60), Feature_1 – CYLINDRICAL PAD (Hex head screw ISO 4018 M12 x 60), Feature_1 – CYLINDRICAL HOLE (Plain washer ISO 7089 M12) and Feature_1 – CYLINDRICAL HOLE (Hex nut ISO 7417 M12).
14	Guarantee the accessibility of the connections and elements of an assembly (screws, nuts, bolts, snap rings, dowel pins, grease nipples, nails, rivets, tabs, keys etc.) for assembly and disassembly operations in bolted assembly	→ Jib crane.stp (Column.stp vs. Hex head screw ISO 4012 M16 x 45.stp)	→ Assembly features: → Feature_3 – REINFORCING RECTANGULAR PAD (Column), Feature_1 – CYLINDRICAL PAD (Hex head screw ISO 4012 M16 x 45).
4	Guarantee chamfered/countersunk insertion holes and chamfered screw ends in the manual assembly process of bolted components	→ Jib crane.stp (holes of the parts: Column.stp, Arm.stp, Stopper.stp, Pivot wall.stp)	→ Assembly features: → All holes of the parts: Column.stp, Arm.stp, Stopper.stp, Pivot wall.stp

The first design issue (assembly rule#7) one since it can affect the assembly feasibility. In particular, the problem refers to the need to have holes that are hosting screws and rivets starting and ending on a flat surface. Fastening is not well-positioned and safe if the surface is not flat (i.e., there is an angle different than 90° between the in/out surface and the hole axis). The following features determine the non-validated assembly rule#7:

- Feature_1 – HOLE RECTANGULAR PATTERN (Column),
- Feature_1 - HOLE RECTANGULAR PATTERN (Arm),
- Feature_1 – CYLINDRICAL PAD (Hex head screw ISO 4018 M12 x 60),
- Feature_1 – CYLINDRICAL HOLE (Plain washer ISO 7089 M12), and

- Feature_1 – CYLINDRICAL HOLE (Hex nut ISO 7417 M12). Parameter or threshold to verify: Angle required: 90°. Actual angle: 97,97°.

The second design issue (assembly rule#8) is a critical one since it can affect the assembly feasibility. This issue is referred to the minimum distance between the axis of two or more screws. In the case of bolted connections, it is necessary to maintain a certain distance between two adjacent screws equal to 1.2 D (diameter of the first screw) plus 1.2 d (diameter of the second screw) to avoid assembly problems. In fact, if the screws used for assembly have a head with an overall dimension greater than the diameter of the screw itself (for example, hexagonal head or hexagon socket screws), these could interfere during the assembly phase, making unfeasible the assembly process. Furthermore, this rule could be applied considering the load constraints, which suggest the minimum distance between two consecutive screws in the function of load direction. In the case of parallel load direction, this distance is 2.4 times the diameter of the screw. In contrast, for a perpendicular load, this distance must be three times the diameter. The following features determine the non-validated assembly rule#8:

- Feature_1 - HOLE RECTANGULAR PATTERN (Column),
- Feature_1 - HOLE RECTANGULAR PATTERN (Arm),
- Feature_1 – CYLINDRICAL PAD (Hex head screw ISO 4018 M12 x 60),
- Feature_1 – CYLINDRICAL HOLE (Plain washer ISO 7089 M12), and
- Feature_1 – CYLINDRICAL HOLE (Hex nut ISO 7417 M12). Parameter or threshold to verify: Minimum required diameter gap: 31,2 mm. Actual diameter gap: 30 mm.

The third design issue (assembly rule#6) is classified as information. It refers to a particular type of fasteners (e.g. screws with integrated washers), able to reduce the number of assembly tasks and the assembly time. The following features determine the non-validated assembly rule#6:

- Hex nut ISO 4034 M10, Plain washer Xlarge ISO 7094 M10, Plain washer ISO 7089 M10 and Hex head screw ISO 4016 M10 x 35 in the connection between Stopper (5) and Arm (6).
- Plain washer ISO 7089 M12, Hex head screw ISO 4018 M12 x 60 and Hex nut ISO 7417 M12 in the connection between packing Column (13) and Arm (6).
- Hex head screw ISO 4012 M16 x 45, Plain washer ISO 7089 M16 and Hex nut ISO 4034 M16 in the connection between Column (13) and Arm (6).
- Hex head screw ISO 7412 M30 x 140 and Hex head screw ISO 4018 M16 x 80 in the connection between Pivot wall (16) and wall.

The fourth design issue (assembly rule#25) is classified as a warning. It affects the correct design of the assembly (load resistance). The issue refers to the need to guarantee a minimum distance between the screw hole and component edge in bolted/riveted assembly. This rule allows to avoid local deformations of the piece, and it requires considering the load condition. The minimum distance between the screw axis and an edge (along the load direction), suggested by the literature, is 1.2 times the diameter of the screw. Following the design requirements, this distance can rise up to 1.5 times the diameter for a perpendicular direction. The following features determine the non-validated assembly rule#25:

- Feature_1 – HOLE RECTANGULAR PATTERN (Column), and

- Feature_2 – RECTANGULAR PAD (Column). Parameter or threshold to verify: Minimum required gap: 15,6 mm. Actual gap: 15,4 mm.

The fifth design issue (assembly rule#3) is a critical one since it can affect the assembly feasibility. In particular, the issue refers to the need to keep aligned screw, nut and hole axis in the manual assembly process of bolted components. Holes misalignment or gaps can inhibit the assembly task. The following features determine the non-validated assembly rule#3:

- Feature_1 – HOLE RECTANGULAR PATTERN (Column),
- Feature_1 – HOLE RECTANGULAR PATTERN (Arm),
- Feature_1 – CYLINDRICAL PAD (Hex head screw ISO 4018 M12 x 60),
- Feature_1 – CYLINDRICAL PAD (Hex head screw ISO 4018 M12 x 60),
- Feature_1 – CYLINDRICAL HOLE (Plain washer ISO 7089 M12), and
- Feature_1 – CYLINDRICAL HOLE (Hex nut ISO 7417 M12). Parameter or threshold to verify: No axis gap or misalignment. Actual gap: 1,3 mm between Feature_1 – CYLINDRICAL HOLE (Hex nut ISO 7417 M12) and Feature_1 – HOLE RECTANGULAR PATTERN (Arm)

The sixth design issue (assembly rule#14) is again a critical one since it can affect the assembly feasibility. This issue is referred to the need to guarantee the fasteners accessibility for assembly and disassembly operations. The physical obstruction of the fasteners (e.g., screws, nuts, pins, grease nipples, nails, rivets, keys) is a condition that does not allow to perform the assembly task. The following features determine the non-validated assembly rule#14:

- Feature_3 – REINFORCING RECTANGULAR PAD (Column),
- Feature_1 – CYLINDRICAL PAD (Hex head screw ISO 4012 M16 x 45). Parameter or threshold to verify: Minimum space required (screw height): 55 mm. Actual space: 45 mm.

The seventh design issue (assembly rule#4) is classified as a warning and recommends having chamfered holes to facilitate the insertion of screws in the manual assembly process of bolted components. Since all the assembly holes were not chamfered in the original design, all the feature holes determine the non-validated assembly rule#4.

Table 5 summarises the identified design issues concerning the features recognition from the 3D CAD model. All the other features that fulfil the design guidelines are not reported within this table.

Table 5: non-validated rules identified for the jib-crane example

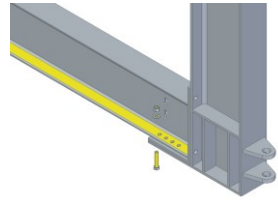
Knowledge processing			Knowledge representation	
Assembly process	Material	CAD feature recognition	DfA guideline syntax	Picture
Class: All types of assemblies Type - level: Fastening	Class: All materials Type: N.A.	Recognize: Angle between hole axis and surface (α) PMI: N.A. Dimensions/geometry: $\alpha = 90^\circ$	Action: Guarantee Subject: Flat surfaces for the insertion holes for screws Context: In the manual assembly process of bolted components	

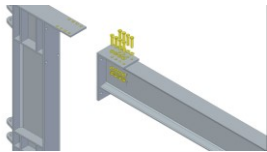
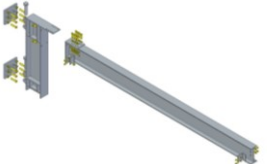
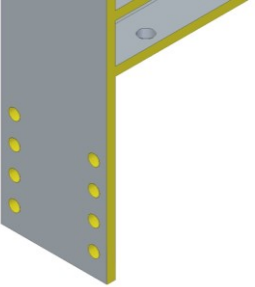
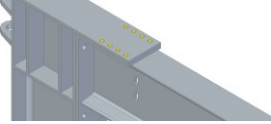
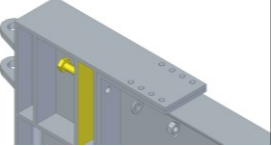
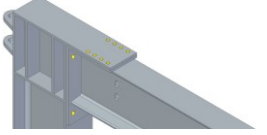
<p>Class: Manual assembly</p> <p>Type - level: Fastening</p>	<p>Class: All materials</p> <p>Type: N.A.</p>	<p>Recognize: Diameter of the first screw (Ds); Diameter of the second screw (ds); Distance between the screw axis (La)</p> <p>PMI: N.A.</p> <p>Dimensions/geometry: $La > 1,2Ds + 1,2ds$</p>	<p>Action: Guarantee</p> <p>Subject: Minimum distance between the axis of two or more screw</p> <p>Context: In the manual assembly process of bolted components</p>	
<p>Class: Manual assembly</p> <p>Type - level: Fastening</p>	<p>Class: All materials</p> <p>Type: N.A.</p>	<p>Recognize: Screw; Washer; Nut</p> <p>PMI: N.A.</p> <p>Dimensions/geometry: N.A.</p>	<p>Action: Prefer</p> <p>Subject: The use of combined fasteners</p> <p>Context: In the manual assembly process of bolted components</p>	
<p>Class: All types of assemblies</p> <p>Type - level: Fastening and Rivetting</p>	<p>Class: All materials</p> <p>Type: N.A.</p>	<p>Recognize: Diameter of the screw (Ds); Distance between the screw axis and component edge (Le)</p> <p>PMI: N.A.</p> <p>Dimensions/geometry: $Le > 1,2Ds$</p>	<p>Action: Guarantee</p> <p>Subject: The minimum distance between screw hole and component edge</p> <p>Context: In bolted/riveted assembly</p>	
<p>Class: All types of assemblies</p> <p>Type - level: Fastening</p>	<p>Class: All materials</p> <p>Type: N.A.</p>	<p>Recognize: Hole axis (Ah); Screw axis (As); Nut axis (An); Threaded hole axis (At)</p> <p>PMI: N.A.</p> <p>Dimensions/geometry: $As = An = Ah = At$</p>	<p>Action: Keep aligned</p> <p>Subject: Screw, nut and hole axis</p> <p>Context: In assembly process of bolted components</p>	
<p>Class: All types of assemblies</p> <p>Type - level: Fastening and Rivetting</p>	<p>Class: All materials</p> <p>Type: N.A.</p>	<p>Recognize: Connections and elements dimensions (De) (Screws, Nuts, Bolts, Snap rings, Dowel pins, Grease nipples, Nails, Rivets, Tabs, Keys); Space available (Ds); Elements insertion direction.</p> <p>PMI: N.A.</p> <p>Dimensions/geometry: $Ds > De$</p>	<p>Action: Guarantee the accessibility</p> <p>Subject: Of the connections and elements of an assembly (screws, nuts, bolts, snap rings, dowel pins, grease nipples, nails, rivets, tabs, keys etc.)</p> <p>Context: for assembly and disassembly operations in bolted assembly</p>	
<p>Class: Manual assembly</p> <p>Type - level: Fastening and Rivetting</p>	<p>Class: All materials</p> <p>Type: N.A.</p>	<p>Recognize: Threaded hole; The chamfer on the threaded hole; Hole chamfer; Screw chamfer</p> <p>PMI: N.A.</p> <p>Dimensions/geometry: Chamfer $< 1 \times 45^\circ$</p>	<p>Action: Guarantee</p> <p>Subject: Chamfered/countersunk insertion holes and chamfered screw ends</p> <p>Context: In the manual assembly process of bolted components</p>	

After identifying design issues (non-validated rules), the designer can redesign the product in compliance with the DfA rules. A new version of the 3D model is developed by changing the CAD features according to the design guidelines. Then, the new model can be validated by repeating the process. The changes in the jib crane design consisted of:

- Feature_1 – HOLE RECTANGULAR PATTERN (Column): increasing of hole distance from 40 mm to 50 mm and new coordinates to avoid non-flat surface between Feature_1 – THREADED CYLINDRICAL PAD (Hex head screw ISO 4018 M12 x 60) and Feature_2 – T-EXTRUSION (Arm) (Feature_1 – HOLE RECTANGULAR PATTERN_MOD (Column)). Also, increasing the hole distance allows the alignment between Feature_1 – HOLE RECTANGULAR PATTERN (Column) and Feature_1 – HOLE RECTANGULAR PATTERN (Arm).
- Feature_3 – HOLE RECTANGULAR PATTERN (Column): decreasing of hole distance from 40 mm to 30 mm to guarantee the alignment between Feature_3 – HOLE RECTANGULAR PATTERN (Column) and Feature_4 – HOLE RECTANGULAR PATTERN (Arm).
- Feature_2 – RECTANGULAR PAD (Column): changing feature dimensions cause new feature coordinates of Feature_1 – HOLE RECTANGULAR PATTERN (Column) (Feature_2 – PAD (Column)). With this updated feature, the distance between screw hole and component edge are greater than the minimum required gap: 15,6 mm vs 16,6 mm (Feature_1 – HOLE RECTANGULAR PATTERN (Column) and Feature_2 – RECTANGULAR PAD (Column)).
- Feature_1 – HOLE RECTANGULAR PATTERN (Arm): increasing of hole distance from 30 mm to 50 mm and new coordinates to avoid non-flat surface between Feature_1 – THREADED CYLINDRICAL PAD (Hex head screw ISO 4018 M12 x 60) and Feature_2 – T-EXTRUSION (Arm) (Feature_1 – HOLE RECTANGULAR PATTERN_MOD (Arm)).
- Feature_2 – RECTANGULAR PAD (Arm): changing feature dimensions cause new feature coordinates of Feature_1 – HOLE RECTANGULAR PATTERN (Column) (Feature_2 – RECTANGULAR PAD_MOD (Column)).
- Replacement of the screws (Hex head screw ISO 4018 M12 x 60) and washers (Plain washer ISO 7089 M12) with flanged screws (Hex head screw DIN 6921 M12 x 40).
- Replacement of the nuts (Hex nut ISO 7412 M12) and washers (Plain washer ISO 7089 M12) with flanged nuts (Hex nut DIN ISO 6923 M12).
- Replacement of the nuts (Hex nut ISO 4034 M16) and washers (Plain washer ISO 7089 M16) with flanged nuts (Hex nut DIN ISO 4161 M16).
- Replacement of the screws (Hex head screw ISO 4016 M10 x 35) and washers (Plain washer ISO 7089 M10) with flanged screws (Hex head screw DIN 4162 M10 x 35).
- Replacement of the screws (Hex head screw ISO 4018 M16 x 80) and washers (Plain washer ISO 7089 M16) with flanged screws (Hex head screw DIN 4162 M16 x 80).
- Reverse the insertion direction of Hex head screw ISO 4012 M16 x 45 to guarantee the accessibility. Now the screw is inserted in the opposite direction. The features involved in the assembly are Feature_4 – HOLE RECTANGULAR PATTERN (Arm) vs Feature_1 – CYLINDRICAL PAD (Hex head screw ISO 4012 M16 x 45)).

- Holes countersink for the parts: Column, Arm, Stopper, Pivot wall.

Table 8 and Table 9 of Appendix A, report the design changes performed, respectively, on the Column.stp and Jib crane.stp.

5. Conclusions

Process planning and engineering design for mechanical products are concurrent processes requiring collaboration among all parties to optimize the project outcomes such as cost, quality, performance, and reliability. The increasing competitiveness of the markets is pushing designers to develop more and more competitive products. For this aim, designers must follow a growing number of design tips and rules, but the problem concerns finding the set of rules to apply at the right time. Thus, the proposed CAD-integrated DfX framework aims to capture, retrieve and suggest design rules according to a given design context and a specific objective to pursue.

The proposed approach enables the identification of design issues, analysis of the rules propagation in the CAD design environment and distribution of “know-how” to designers in the context of their specific design activity (explicit knowledge). This activity is on the critical path of the engineering design process. Thus the developed method is supporting knowledge-intensive and prone to error engineering tasks. This work encompasses several disciplines (e.g., knowledge formalization for engineering applications, 3D model feature recognition, computational analysis) to develop a tool extending the current CAD capabilities. The adoption of the proposed approach highlights several outcomes. The first one is related to the effort and time required for developing DfX (where x is the target to optimize) compliant products. With this approach, design review loops may be reduced, thus improving the product time-to-market reducing knowledge-intensive engineering practices. Another interesting outcome concerns the possibility of sharing engineering knowledge across members of a design team and reusing it each time needed. Moreover, providing the results of the DfX analyses in a proper format (report of the design changes and benefits), designers can learn from it, and this will result in a fewer number of iterations as the designer becomes more experienced.

The case study presented in this paper refers to applying the proposed method in the context of DfA. A jig-crane assembly made of 91 components was analysed to verify the compliance of 3D CAD features against the collected DfA rules (a database of 74 DfA rules). Despite the large number of features involved in this complex assembly and the manual analysis of the 3D CAD features, the method is efficient. It allows recognizing assembly issues and non-compliant features. The procedure is applicable also for assemblies made of a higher number of parts and with a higher quantity of features. The increasing complexity required for managing such products pushes research toward adopting algorithms and software tools for automating the methodology presented in this paper (e.g. a software integrated with a 3D CAD system). The approach presented in this paper is the backbone of a software tool for virtual assisting designers in evaluating possible design inconsistencies. With regards to this advantage, there is the possibility to use the proposed approach for teaching initiatives and to educate the young generation of designers with a learning-by-doing system. Indeed, the learning curve of this new generation of engineers and designers can be boosted by adopting this method.

Some limitations were observed with the development of the proposed CAD-integrated DfX framework. The first one concerns updating the DfX rules DB, which requires the analysis of new documents to retrieve additional tacit knowledge that can be translated into explicit knowledge using the proposed knowledge-based system (rule insertion form). Another limitation deals with the feature recognition system which needs to be automatized to avoid that the type of feature recognized can depend on the viewpoint of the observer. Finally, a multi-objective approach may help the designer in the

decision making process when a trade-off analysis between functional requirements and other design objectives is necessary.

Due to the limitations mentioned above, future works will focus on three main topics: (i) develop a software tool based on this methodology, (ii) extend KPIs assessment, and (iii) provide a suitable multi-objective approach. Regarding the first topic, dedicated research activities to DB rules implementation and graphic user interface (GUI) are mandatory to provide a tangible software tool to support design activities during 3D modelling. This future implementation will lead to translating the proposed framework into a software tool (software application). An important aspect is related to the possibility to display the rules within the CAD environment. In addition, an important effort is necessary in relation to the automatic recognition of CAD features. Currently, this is a manual activity that is time-consuming and prone to error (observer-dependent). A software tool for feature recognition which is CAD-independent would limit the possibility to have a mismatch between the feature that is recognized and its meaning in the given context. Regarding the second and the third topics, analytical models different than cost estimation can be adopted for sustainability assessment (i.e., economic, environmental, and social KPIs) and integrate them for a single issue score. In this manner, it will be possible to simultaneously consider multiple design targets (e.g., Design for Environment, Design for Manufacturing, Design for Disassembly). Dedicated indices can be firstly identified (i.e., CO₂ emissions), then linked with analytical models for their calculation and lastly connected to the features properties. Thus, a complete overview of the project requirements and life cycle performances can be achieved in the early phases of the product development.

References

- Ahmad, M., Ferrer, B.R., Ahmad, B., Vera, D., Martinez Lastra, J.L., Harrison, R., Knowledge-based PPR modelling for assembly automation. *CIRP Journal of Manufacturing Science and Technology*, (2018). Vol. 21, pp. 33-46. <https://doi.org/10.1016/j.cirpj.2018.01.001>.
- Ashby, M.F., *Materials Selection in Mechanical Design*. 4th Edition, (2010). Butterworth-Heinemann.
- Benabdellah, A.C., Bouhaddou, I., Benghabrit, A., Benghabrit, O., A systematic review of design for X techniques from 1980 to 2018: concepts, applications, and perspectives. *The International Journal of Advanced Manufacturing Technology*, (2019). Vol. 102, Issue 9-12, pp 3473-3502. <https://doi.org/10.1007/s00170-019-03418-6>.
- Campi, F., Favi, C., Mandolini, M., Germani, M., Using design geometrical features to develop an analytical cost estimation method for axisymmetric components in open-die forging. *Procedia CIRP*, (2019). Vol. 84, pp. 656-661. <https://doi.org/10.1016/j.procir.2019.04.324>.
- Campi, F., Mandolini, M., Favi, C., Checcacci, M., Germani, M., An analytical cost estimation model for the design of axisymmetric components with open-die forging technology. *The International Journal of Advanced Manufacturing Technology*, (2020). <https://doi.org/10.1007/s00170-020-05948-w>.
- Chang, X., Rai, R., Terpenney, J., Development and Utilization of Ontologies in Design for Manufacturing. *Journal of Mechanical Design*, (2010). Vol. 132. <https://doi.org/10.1115/1.4000697>.
- Chang, K.-H., *Product Manufacturing and Cost Estimating Using CAD/CAE*. The Computer Aided Engineering Design Series, (2013). Publisher: Academic Press.
- Chen, K.-H., Chen, S.J., Lin, L., Changchien, S.W. An integrated graphical user interface (GUI) for concurrent engineering design of mechanical parts. *Computer Integrated Manufacturing Systems*, (1998). Vol. 11, Issues 1-2), pp. 91-112. [https://doi.org/10.1016/S0951-5240\(98\)00016-0](https://doi.org/10.1016/S0951-5240(98)00016-0).
- Chhim, P., Chinnam, R.B., Sadawi, N., Product design and manufacturing process based ontology for manufacturing knowledge reuse. *Journal of Intelligent Manufacturing*, (2019). Vol. 30, pp. 905-916. <https://doi.org/10.1007/s10845-016-1290-2>.
- Chiu, M.-C., Okudan, G.E., Evolution of Design for X Tools Applicable to Design Stages: A Literature Review. *Proceedings of the ASME 2010 International Design Engineering Technical Conferences & Computers and Information in Engineering Conference*, (2010), Montreal, Quebec, Canada.
- Debord, S., Segonds, F., Pinquié, R., Veron, P., Croué, N., Proposition of a design rules framework. In proceedings of 25ème colloque des Sciences de la conception et de l'innovation - CONFERE 2018, Budapest, Hungary, (2018).
- Desai, A., Mital, A., Incorporating work factors in design for disassembly in product design. *Journal of Manufacturing Technology Management*, (2005). Vol. 16, Issue 7, pp. 712-732. <https://doi.org/10.1108/17410380510619932>.
- DFMPRO 2020 - <https://dfmpro.com/> accessed on 08/01/2020
- Dombrowski, U., Schmidt, S., Schmidtchen, K., Analysis and Integration of Design for X Approaches in Lean Design as basis for a Lifecycle Optimized Product Design, *Procedia CIRP* (2014), Vol. 15, pp. 385-390, <https://doi.org/10.1016/j.procir.2014.06.023>.

- Faerber, M., Jochaud, F., Stöber, C., Jablonski S., Meerkamm, H., Knowledge oriented process management for DFX. In the Proceedings of the International DESIGN conference - DESIGN2008 (2008).
- Favi, C., Germani, M., Mandolini, M., A Multi-Objective Design Approach to Include Material, Manufacturing and Assembly Costs in the Early Design Phase. *Procedia CIRP*, (2016). Vol. 52, pp. 251-25. <https://doi.org/10.1016/j.procir.2016.07.043>.
- Favi, C., Germani, M., Mandolini, M., Development of complex products and production strategies using a multi-objective conceptual design approach, *The International Journal of Advanced Manufacturing Technology*, (2018). Vol. 95, Issue 1-4, pp 1281–1291. <https://doi.org/10.1007/s00170-017-1321-y>.
- Favi, C., Marconi, M., Germani, M., Mandolini, M., A design for disassembly tool oriented to mechatronic product de-manufacturing and recycling. *Advanced Engineering Informatics*, (2019). Vol. 39, pp. 62-79. <https://doi.org/10.1016/j.aei.2018.11.008>.
- Favi, C., Garziera, R., Campi, F., A Rule-Based System to Promote Design for Manufacturing and Assembly in the Development of Welded Structure: Method and Tool Proposition. *Applied Sciences* (2021), 11, 2326. <https://doi.org/10.3390/app11052326>.
- Feyen, R., Liu, Y., Chaffin, D., Jimmerson, G., Joseph, B., Computer-aided ergonomics: a case study of incorporating ergonomics analyses into workplace design, *Applied Ergonomics*, (2000). Vol. 31, Issue 3, pp. 291-300. [https://doi.org/10.1016/S0003-6870\(99\)00053-8](https://doi.org/10.1016/S0003-6870(99)00053-8).
- Gembarski, P.C., Three ways of integrating computer-aided design and knowledge-based engineering. *International Design Conference – DESIGN 2020* <https://doi.org/10.1017/dsd.2020.313>.
- Holt, R., Barnes, C., Towards an integrated approach to “Design for X”: an agenda for decision-based DfX research. London: Springer; 2009.
- Huang, G.Q. and Mak, K. L., The DfX Shell: A Generic Framework For Developing Design For X Tools. *Robotics & Computer-Integrated Manufacturing*, (1997). Vol. 13, No. 3, pp. 271-280.
- Huang, G.Q. and Mak, K. L., Web-based product and process data modelling in concurrent design for X. *Robotics and Computer-Integrated Manufacturing*, (1999i). Vol. 15, pp. 53-63.
- Komoto, H., Tomiyama, T., A framework for computer-aided conceptual design and its application to system architecting of mechatronics products. *Computer-Aided Design*, (2012). Vol. 44, Issue 10, pp. 931-946. <https://doi.org/10.1016/j.cad.2012.02.004>.
- Lee, H.S., Chang, S.L., Development of a CAD/CAE/CAM system for a robot manipulator. *Journal of Materials Processing Technology*, (2003). Vol. 140, Issues 1-3, pp. 100-104. [https://doi.org/10.1016/S0924-0136\(03\)00695-2](https://doi.org/10.1016/S0924-0136(03)00695-2).
- Li, Z., Zhou, X., Wang, W.M., Huang, G., Tian, Z., Huang, S., An ontology-based product design framework for manufacturability verification and knowledge reuse. *The International Journal of Advanced Manufacturing Technology*, (2018). Vol. 99, pp. 2121-2135. <https://doi.org/10.1007/s00170-018-2099-2>.
- Ma, H., Zhou, X., Liu, W. et al., A feature-based approach towards integration and automation of CAD/CAPP/CAM for EDM electrodes. *The International Journal of Advanced Manufacturing Technology*, (2018). Vol. 98, pp. 2943-2965. <https://doi.org/10.1007/s00170-018-2447-2>.

- Mantripragada, R., Kinzel, G., Altan, T., A computer-aided engineering system for feature-based design of box-type sheet metal parts. *Journal of Materials Processing Technology*, (1996). Vol. 57, pp. 241-248. [https://doi.org/10.1016/0924-0136\(95\)02071-3](https://doi.org/10.1016/0924-0136(95)02071-3).
- Marconi, M., Germani, M., Favi, C., Raffaelli, R., CAD feature recognition as a means to prevent ergonomics issues during manual assembly tasks. *Computer-Aided Design and Applications*, (2018). Vol. 15, Issue 5. <https://doi.org/10.1080/16864360.2018.1441240>.
- Mital, A., Desai, A., Subramanian, A., Mital, A., *Product Development A Structured Approach to Consumer Product Development, Design, and Manufacture*, (2015). Second Edition. Elsevier.
- Morbidoni A., Favi C., Germani, M., CAD-Integrated LCA Tool: Comparison with dedicated LCA Software and Guidelines for the Improvement. *Glocalized Solutions for Sustainability in Manufacturing*, (2011). pp 569-574. https://doi.org/10.1007/978-3-642-19692-8_99.
- Molcho, G., Zipori, Y., Schneur, R., Rosen, O., Goldstein, D., Shpitalni, M., Computer aided manufacturability analysis: Closing the knowledge gap between the designer and the manufacturer. *CIRP Annals - Manufacturing Technology*, (2008). Vol. 57, pp. 153-158. <https://doi.org/10.1016/j.cirp.2008.03.046>.
- Nasr, E.A., Kamrani, A.K., A new methodology for extracting manufacturing features from CAD system. *Computers & Industrial Engineering*, (2006). Vol. 51, pp. 389-415. <https://doi.org/10.1016/j.cie.2006.08.004>.
- Nasr, E.A., Kamrani, A.K., *Computer-based design and manufacturing an information-based approach*, (2007). Springer.
- Nomaguchi, Y., Fujita, K., *Ontology Building For Design Knowledge Management Systems Based On Patterns Embedded In Design-For-X Methodologies*. In the Proceedings of the International Conference On Engineering Design - ICED07 (2007)
- Pahl, G., Beitz, W., Feldhusen, J., Grote, K.H., *Engineering Design: A Systematic Approach*. 3rd ed., (2007). Springer.
- Poorkiany, M., Johansson, J., Elgh, F., Capturing, structuring and accessing design rationale in integrated product design and manufacturing processes. *Advanced Engineering Informatics*, (2016). Vol. 30, pp. 522-536. <http://dx.doi.org/10.1016/j.aei.2016.06.004>.
- Robertson, B.F., Radcliffe, D.F., Impact of CAD tools on creative problem solving in engineering design, *Computer-Aided Design*, (2009). Vol. 41, Issue 3, pp. 136-146, <https://doi.org/10.1016/j.cad.2008.06.007>.
- Sanfilippo, E.M., Borgo, S., What are features? An ontology-based review of the literature, *Computer-Aided Design*, (2016). Vol. 80, pp. 9-18. <http://dx.doi.org/10.1016/j.cad.2016.07.001>.
- Schmidt, J., Peruzzini, M., Zattar Paganin, L.B., Sato, R.S., Borsato M., Expert system based on ontological model to support the detailed design of agricultural machinery: a case of hydraulic hoses (2020). Vol.18, Issue 1, pp.53-69. <http://dx.doi.org/10.4322/pmd.2019.022>.
- Staub-French, S., Fischer, M., Kunz, J., Ishii, K., Paulson, B., A feature ontology to support construction cost estimating. *AI EDAM: Artificial Intelligence for Engineering Design, Analysis and Manufacturing*, (2003). Vol. 17, pp 133-154. <https://doi.org/10.1017/S0890060403172034>.

- Tao, J., Chen, Z., Yu, S., Liu, Z., Integration of Life Cycle Assessment with computer-aided product development by a feature-based approach, *Journal of Cleaner Production*, (2017). Vol. 143, pp.1144-1164. <https://doi.org/10.1016/j.jclepro.2016.12.005>.
- Tao, J., Li, L., Yu, S., An innovative eco-design approach based on integration of LCA, CAD\CAE and optimization tools, and its implementation perspectives. *Journal of Cleaner Production*, (2018). Vol. 187, pp. 839-851. <https://doi.org/10.1016/j.jclepro.2018.03.213>.
- Ulrich, K.T., Eppinger, S.D., *Product Design and Development*, 5th edition. USA, (2011). McGraw-Hill Education.
- Yang, D., Dong, M., Miao, R., Development of a product configuration system with an ontology-based approach, *Computer-Aided Design*, (2008). Vol. 40, Issue 8, pp. 863-878. <https://doi.org/10.1016/j.cad.2008.05.004>.

Appendix A. Component and geometric features of the case study

Table 6: component, geometric and interaction features for the Column.stp component (original design)

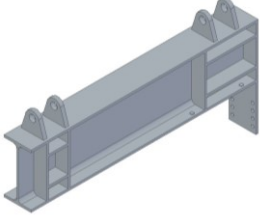
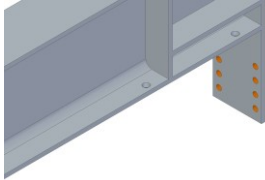
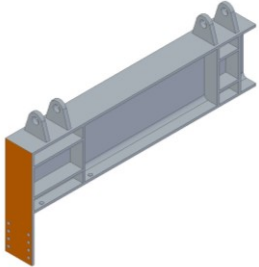
Feature type	Feature image	Feature description
Component feature		<ul style="list-style-type: none"> → Material: S 275JR → Shape: Prismatic → Volume: 5488375,96 [mm³] → Area: 1242147,61 [mm²] → Dimensions: 120,00*1010,00*530,00 [mm]
Geometric feature		<ul style="list-style-type: none"> → Material: S 275JR → Type of feature: Feature_1 – HOLE RECTANGULAR PATTERN → Coordinates of the feature in reference with origin: [40,00;1010,00;-325,00]; [40,00;1010,00;-355,00]; [40,00;1010,00;-385,00]; [40,00;1010,00;-415,00]; [-40,00;1010,00;-325,00]; [-40,00;1010,00;-355,00]; [-40,00;1010,00;-385,00]; [-40,00;1010,00;-415,00] → Properties of the feature: <ul style="list-style-type: none"> → For holes: <ul style="list-style-type: none"> → Diameter: 13 [mm] → Length: 10 [mm] → Number: 8 [ad.] → Volume of the feature: 1327,32*8 [mm³] → Area of the feature: 673,87*8 [mm²] → Faces of the feature: <ul style="list-style-type: none"> → Circular_face_01.01*8 → Circular_face_01.02*8 → Cilindrical_face_01.01*8 → PMI: <ul style="list-style-type: none"> → Specific roughness: <ul style="list-style-type: none"> → Ra 1,6 [μm] on: <ul style="list-style-type: none"> → Cilindrical_face_01.01*8 → Specific tolerance: NO → Coating: NO
Geometric feature		<ul style="list-style-type: none"> → Material: S 275JR → Type of feature: Feature_2 – RECTANGULAR PAD → Coordinates of the feature in reference with origin: [60,00;1010,00;00,00]; [-60,00;1010,00;00,00]; [60,00;1010,00;-440,00]; [-60,00;1010,00;-440,00] → Properties of the feature: <ul style="list-style-type: none"> → Height: 10 [mm] → Volume of the feature: 528000,00 [mm³] → Area of the feature: 116800,00 [mm²] → Faces of the feature: <ul style="list-style-type: none"> → Rectangular_face_02.01 → Rectangular_face_02.02 → Rectangular_face_02.03 → Rectangular_face_02.04 → Rectangular_face_02.05 → Rectangular_face_02.06 → PMI: <ul style="list-style-type: none"> → Specific roughness: <ul style="list-style-type: none"> → Ra 1,6 [μm] on: <ul style="list-style-type: none"> → Rectangular_face_02.01 → Rectangular_face_02.02 → Specific tolerance: NO → Coating: NO

<p>Interaction feature</p>		<ul style="list-style-type: none"> → Material: S 275JR → Type of feature: Feature_2 – RECTANGULAR PAD vs. Feature_1 – HOLE RECTANGULAR PATTERN <ul style="list-style-type: none"> → Coordinates of the feature vs. coordinate of the features: <ul style="list-style-type: none"> [60,00;1010,00;00,00]; [-60,00;1010,00;00,00]; [60,00;1010,00;-440,00]; [-60,00;1010,00;-440,00] vs. [40,00;1010,00;-325,00]; [40,00;1010,00;-355,00]; [40,00;1010,00;-385,00]; [40,00;1010,00;-415,00]; [-40,00;1010,00;-325,00]; [-40,00;1010,00;-355,00]; [-40,00;1010,00;-385,00]; [-40,00;1010,00;-415,00] → Properties of the feature vs. properties of the feature: <ul style="list-style-type: none"> → Distance between Feature_2 – RECTANGULAR PAD edge vs. hole of Feature_1 - HOLE RECTANGULAR PATTERN: 15,4 [mm] → Volume of the feature vs. volume of the feature/s: 528000,00 [mm³] vs. 1327,32*8 [mm³] → Area of the feature vs. area of the feature/s: 116800,00 [mm²] vs. 673,87*8 [mm²] → Faces of the feature vs. faces of the feature/s: <ul style="list-style-type: none"> → Rectangular_face_02.03 vs. Cylindrical_face_01.01 → PMI vs. PMI: <ul style="list-style-type: none"> → Specific roughness: <ul style="list-style-type: none"> → Ra 1,6 [μm] vs. Ra 1,6 [μm] on: <ul style="list-style-type: none"> → Cylindrical_face_01_01 vs. Cylindrical_face_01.01 → Specific tolerance: NO → Coating: NO
----------------------------	---	--

Table 7: assembly features for the jib crane assembly (original design)

Feature type	Feature image	Feature description
Assembly feature		<ul style="list-style-type: none"> → Material vs. material: 39NiCrMo3 vs. AISI 316 → Type of feature vs. type/s of feature/s: Feature_1 – THREADED CYLINDRICAL PAD (Hex head screw ISO 4018 M12 x 60) vs. Feature_1 – HOLE (Plain washer ISO 7089 M12) → Coordinates of the feature vs. coordinates of the feature/s: <ul style="list-style-type: none"> → [00,00;00,00;00,00] vs. [00,00;00,00;00,00] → Properties of the feature vs. properties of the feature: <ul style="list-style-type: none"> → Type of thread of Feature_1 – THREADED CYLINDRICAL PAD (Hex head screw ISO 4018 M12 x 60) vs. diameter of Feature_1 –HOLE (Plain washer ISO 7089 M12): M12 vs. 13 [mm] → Volume of the feature vs. volume of the feature/s: 6785,84 [mm³] vs. 331,83 [mm³] → Area of the feature vs. area of the feature/s: 2488,14 [mm²] vs. 367,57[mm²] → Faces of the feature vs. faces of the feature/s: <ul style="list-style-type: none"> → Cylindrical_face_01.01 vs. Cylindrical_face_01.01 → PMI vs. PMI: <ul style="list-style-type: none"> → Specific roughness: <ul style="list-style-type: none"> → Ra 1,6 [μm] vs. Ra 1,6 [μm] on: <ul style="list-style-type: none"> → Cylindrical_face_01_01 vs. Cylindrical_face_01.01 → Specific tolerance: NO → Coating: NO → Material vs. material: 39NiCrMo3 vs. S 275JR → Type of feature vs. type/s of feature/s: Feature_1 – THREADED CYLINDRICAL PAD (Hex head screw ISO 4018 M12 x 60) vs. Feature_1 – HOLE RECTANGULAR PATTERN (Column) → Coordinates of the feature vs. coordinates of the feature/s: <ul style="list-style-type: none"> → [00,00;00,00;00,00] vs. [-40,00;230,00;72,30] → Properties of the feature vs. properties of the feature: <ul style="list-style-type: none"> → Type of thread of Feature_1 – THREADED CYLINDRICAL PAD (Hex head screw ISO 4018 M12 x 60) vs. diameter of Feature_1 - HOLE RECTANGULAR PATTERN (Column): M12 vs. 13 [mm] → Volume of the feature vs. volume of the feature/s: 6785,84 [mm³] vs. 1327,32 [mm³] → Area of the feature vs. area of the feature/s: 2488,14 [mm²] vs. 673,87 [mm²] → Faces of the feature vs. faces of the feature/s: <ul style="list-style-type: none"> → Cylindrical_face_01.01 vs. Cylindrical_face_01.01 → PMI vs. PMI: <ul style="list-style-type: none"> → Specific roughness: <ul style="list-style-type: none"> → Ra 1,6 [μm] vs. Ra 1,6 [μm] on: <ul style="list-style-type: none"> → Cylindrical_face_01_01 vs. Cylindrical_face_01.01 → Specific tolerance: NO → Coating: NO → Material vs. material: 39NiCrMo3 vs. S 275JR → Type of feature vs. type/s of feature/s: Feature_1 – THREADED CYLINDRICAL PAD (Hex head screw ISO 4018 M12 x 60) vs. Feature_1 – HOLE RECTANGULAR PATTERN (Arm) → Coordinates of the feature vs. coordinates of the feature/s: <ul style="list-style-type: none"> → [00,00;00,00;00,00] vs. [-30,00;230,00;72,30] → Properties of the feature vs. properties of the feature: <ul style="list-style-type: none"> → Type of thread of Feature_1 – THREADED CYLINDRICAL PAD (Hex head screw ISO 4018 M12 x 60) vs. diameter of Feature_1 - HOLE RECTANGULAR PATTERN (Arm): M12 vs. 13 [mm] → Volume of the feature vs. volume of the feature/s: 6785,84 [mm³] vs. 2963,91 [mm³] → Area of the feature vs. area of the feature/s: 2488,14 [mm²] vs. 1177,44 [mm²] → Faces of the feature vs. faces of the feature/s: <ul style="list-style-type: none"> → Cylindrical_face_01.01 vs. Cylindrical_face_01.01 → PMI vs. PMI:

		<ul style="list-style-type: none"> → Specific roughness: <ul style="list-style-type: none"> → Ra 1,6 [µm] vs. Ra 1,6 [µm] on: <ul style="list-style-type: none"> → Cylindrical_face_01_01 vs. Cylindrical_face_01.01 → Specific tolerance: NO → Coating: NO → Material vs. material: 39NiCrMo3 vs. 39NiCrMo3 → Type of feature vs. type/s of feature/s: Feature_1 – THREADED CYLINDRICAL PAD (Hex head screw ISO 4018 M12 x 60) vs. Feature_1 – THREADED HOLE (Hex nut ISO 7417 M12) → Coordinates of the feature vs. coordinates of the feature/s: <ul style="list-style-type: none"> → [00,00;00,00;00,00] vs. [00,00;00,00;00,00] → Properties of the feature vs. properties of the feature: <ul style="list-style-type: none"> → Type of thread of Feature_1 – THREADED CYLINDRICAL PAD (Hex head screw ISO 4018 M12 x 60) vs. type of thread of Feature_1 – THREADED HOLE (Hex nut ISO 7417 M12): M12 vs. M12 → Volume of the feature vs. volume of the feature/s: 6785,84 [mm³] vs. 1357,17 [mm³] → Area of the feature vs. area of the feature/s: 2488,14 [mm²] vs. 678,58 [mm²] → Faces of the feature vs. faces of the feature/s: <ul style="list-style-type: none"> → Cylindrical_face_01.01 vs. Cylindrical_face_01.01 → PMI vs. PMI: <ul style="list-style-type: none"> → Specific roughness: <ul style="list-style-type: none"> → Ra 1,6 [µm] vs. Ra 1,6 [µm] on: <ul style="list-style-type: none"> → Cylindrical_face_01_01 vs. Cylindrical_face_02.01 → Specific tolerance: NO → Coating: NO
Assembly feature		<ul style="list-style-type: none"> → Material vs. material: 39NiCrMo3 vs. S 275JR → Type of feature vs. type/s of feature/s: Feature_1 – THREADED CYLINDRICAL PAD (Hex head screw ISO 4018 M12 x 60) vs. Feature_2 – T-EXTRUSION (Arm) → Coordinates of the feature vs. coordinates of the feature/s: <ul style="list-style-type: none"> → [00,00;00,00;00,00] vs. ([49,00;220,00;3000,00]; [49,00;215,00;3000,00]; [44,78;210,65;3000,00]; [11,03;205,92;3000,00]; [4,05;197,90;3000,00]; [4,05;22,10;3000,00]; [11,03;14,08;3000,00]; [44,78;9,35;3000,00]; [49,00;4,50;3000,00]; [49,00;00,00;3000,00]; [-49,00;220,00;3000,00]; [-49,00;215,00;3000,00]; [-44,78;210,65;3000,00]; [-11,03;205,92;3000,00]; [-4,05;197,90;3000,00]; [-4,05;22,10;3000,00]; [-11,03;14,08;3000,00]; [-44,78;9,35;3000,00]; [-49,00;4,50;3000,00]; [-49,00;00,00;3000,00]) → Properties of the feature vs. properties of the feature: <ul style="list-style-type: none"> → Angle between axis of thread of Feature_1 – THREADED CYLINDRICAL PAD (Hex head screw ISO 4018 M12 x 60) vs. Rectangular_face_02.05 and Rectangular_face_02.06 of Feature_2 – T-EXTRUSION (Arm): 97,97 [°] → Volume of the feature vs. volume of the feature/s: 6785,84 [mm³] vs. 11846220,00 [mm³] → Area of the feature vs. area of the feature/s: 2488,14 [mm²] vs. 2337007,48 [mm²] → Faces of the feature vs. faces of the feature/s: <ul style="list-style-type: none"> → Cylindrical_face_01.01 vs. Rectangular_face_02.05 → Cylindrical_face_01.01 vs. Rectangular_face_02.06 → PMI vs. PMI: <ul style="list-style-type: none"> → Specific roughness: <ul style="list-style-type: none"> → Ra 1,6 [µm] vs. Ra 1,6 [µm] on: <ul style="list-style-type: none"> → Cylindrical_face_01_01 vs. Rectangular_face_02.05 → Cylindrical_face_01_01 vs. Rectangular_face_02.05 → Specific tolerance: NO → Coating: NO

<p>Assembly feature</p>		<ul style="list-style-type: none"> → Material vs. material: 39NiCrMo3 vs. S 275JR → Type of feature vs. type/s of feature/s: Feature_1 – CYLINDRICAL PAD (Hex head screw ISO 4018 M16 x 45) vs. Feature_3 – REINFORCING RECTANGULAR PAD (Column) → Coordinates of the feature vs. coordinates of the feature/s: <ul style="list-style-type: none"> → [00,00;00,00;00,00] vs. [-60,00; 780,53; -185,20] → Properties of the feature vs. properties of the feature: <ul style="list-style-type: none"> → Distance between Feature_3 – REINFORCING RECTANGULAR PAD (Column) and Feature_1 – CYLINDRICAL PAD (Hex head screw ISO 4012 M16 x 45): 45 [mm]. → Volume of the feature vs. volume of the feature/s: 15263,63 [mm³] vs. 124878,40 [mm³] → Area of the feature vs. area of the feature/s: 4389,35 [mm²] vs. 6.632,88 [mm²] → Faces of the feature vs. faces of the feature/s: <ul style="list-style-type: none"> → Rectangular_face_03.01 vs. Cylindrical_face_01.01 → PMI vs. PMI: <ul style="list-style-type: none"> → Specific roughness: <ul style="list-style-type: none"> → No specific roughness vs. Ra 1,6 [μm] on: <ul style="list-style-type: none"> → Rectangular_face_01_01 vs. Cylindrical_face_01.01 → Specific tolerance: NO → Coating: NO
-------------------------	---	---

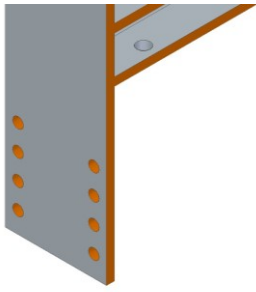
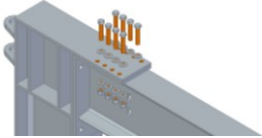
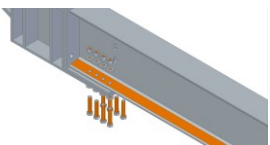
Table 8: component, geometric and interaction features of column component (updated design)

Feature type	Feature image	Feature description
Component feature		<ul style="list-style-type: none"> → Material: S 275JR → Shape: Prismatic → Volume: 5744375,96 [mm³] → Area: 1294213,82 [mm²] → Dimensions: 120,00*1010,00*530,00 [mm]
Geometric feature		<ul style="list-style-type: none"> → Material: S 275JR → Type of feature: Feature_1 – HOLE RECTANGULAR PATTERN_MOD → Coordinates of the feature in reference with origin: [80,00;1010,00;-260,00]; [80,00;1010,00;-310,00]; 80,00;1010,00;-360,00]; [80,00;1010,00;-410,00]; [- 80,00;1010,00;-260,00]; [-80,00;1010,00;-310,00]; [- 80,00;1010,00;-360,00]; [-80,00;1010,00;-410,00] → Properties of the feature: <ul style="list-style-type: none"> → For holes: <ul style="list-style-type: none"> → Diameter: 13 [mm] → Length: 10 [mm] → Number: 8 [ad.] → Volume of the feature: 1327,32*8 [mm³] → Area of the feature: 673,87*8 [mm²] → Faces of the feature: <ul style="list-style-type: none"> → Circular_face_01.01*8 → Circular_face_01.02*8 → Cilindrical_face_01.01*8 → PMI: <ul style="list-style-type: none"> → Specific roughness: <ul style="list-style-type: none"> → Ra 1,6 [μm] on: <ul style="list-style-type: none"> → Cilindrical_face_01.01*8 → Specific tolerance: NO → Coating: NO
Geometric feature		<ul style="list-style-type: none"> → Material: S 275JR → Type of feature: Feature_2 – PAD → Coordinates of the feature in reference with origin: [60,00;1010,00;00,00]; [100,00;1010,00;-240,00]; [100,00;1010,00;-440,00]; [-60,00;1010,00;00,00]; [- 100,00;1010,00;-240,00]; [-100,00;1010,00;-440,00] → Properties of the feature: <ul style="list-style-type: none"> → Height: 10 [mm] → Volume of the feature: 784000,00 [mm³] → Area of the feature: 168.866,20 [mm²] → Faces of the feature: <ul style="list-style-type: none"> → Trapezoidal_face_02.01 → Trapezoidal_face_02.02 → Rectangular_face_02.01 → Rectangular_face_02.02 → Rectangular_face_02.03 → Rectangular_face_02.04 → Rectangular_face_02.05 → Rectangular_face_02.06 → PMI: <ul style="list-style-type: none"> → Specific roughness: <ul style="list-style-type: none"> → Ra 1,6 [μm] on: <ul style="list-style-type: none"> → Trapezoidal_face_02.01 → Trapezoidal_face_02.02 → Specific tolerance: NO → Coating: NO
Interaction feature		<ul style="list-style-type: none"> → Material: S 275JR → Type of feature: Feature_2 – PAD vs. Feature_1 – HOLE RECTANGULAR PATTERN MOD → Coordinates of the feature vs. coordinate of the features: [60,00;1010,00;00,00]; [100,00;1010,00;-240,00]; [100,00;1010,00;-440,00]; [-60,00;1010,00;00,00]; [- 100,00;1010,00;-240,00]; [-100,00;1010,00;-440,00] vs. [80,00;1010,00;-260,00]; [80,00;1010,00;-310,00]; [80,00;1010,00;-360,00]; [80,00;1010,00;-410,00]; [-

		<p>80,00;1010,00;-260,00]; [-80,00;1010,00;-310,00]; [-80,00;1010,00;-360,00]; [-80,00;1010,00;-410,00]</p> <p>→ Properties of the feature vs. properties of the feature:</p> <p>→ Distance between Feature_2 - RECTANGULAR PAD edge vs. hole of Feature_1 - HOLE RECTANGULAR PATTERN: 20,77 [mm]</p> <p>→ Volume of the feature vs. volume of the feature/s: 784000,00 [mm³] vs. 1327,32*8 [mm³]</p> <p>→ Area of the feature vs. area of the feature/s: 168.866,20 [mm²] vs. 673,87*8 [mm²]</p> <p>→ Faces of the feature vs. faces of the feature/s:</p> <p>→ Rectangular_face_02.03 vs. Cilindrical_face_01.01</p> <p>→ PMI vs. PMI:</p> <p>→ Specific roughness:</p> <p>→ Ra 1,6 [μm] vs. Ra 1,6 [μm] on:</p> <p>→ Cylindrical_face_01_01 vs. Cylindrical_face_01.01</p> <p>→ Specific tolerance: NO</p> <p>→ Coating: NO</p>
--	--	--

Table 9: assembly features of jib crane assembly (updated design)

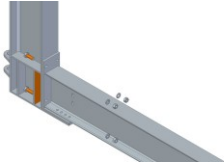
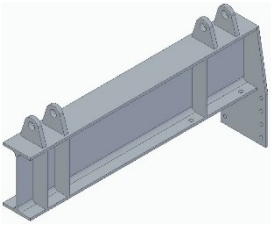
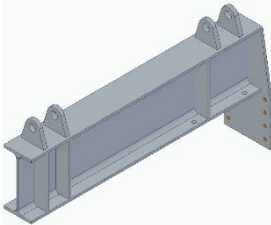
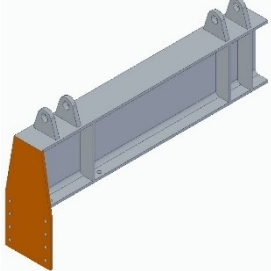
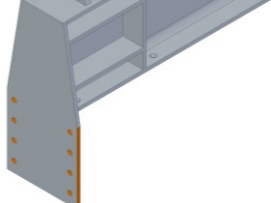
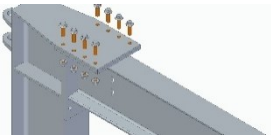
Feature type	Feature image	Feature description
Assembly feature		<ul style="list-style-type: none"> → Material vs. material: 39NiCrMo3 vs. AISI 316 → Type of feature vs. type/s of feature/s: Feature_1 – THREADED CYLINDRICAL PAD (Hex head screw ISO 4018 M12 x 60) vs. Feature_1 – HOLE (Plain washer ISO 7089 M12) → Coordinates of the feature vs. coordinates of the feature/s: <ul style="list-style-type: none"> → [00,00;00,00;00,00] vs. [00,00;00,00;00,00] → Properties of the feature vs. properties of the feature: <ul style="list-style-type: none"> → Type of thread of Feature_1 – THREADED CYLINDRICAL PAD (Hex head screw ISO 4018 M12 x 60) vs. diameter of Feature_1 –HOLE (Plain washer ISO 7089 M12): M12 vs. 13 [mm] → Volume of the feature vs. volume of the feature/s: 6785,84 [mm³] vs. 331,83 [mm³] → Area of the feature vs. area of the feature/s: 2488,14 [mm²] vs. 367,57[mm²] → Faces of the feature vs. faces of the feature/s: <ul style="list-style-type: none"> → Cylindrical_face_01.01 vs. Cylindrical_face_01.01 → PMI vs. PMI: <ul style="list-style-type: none"> → Specific roughness: <ul style="list-style-type: none"> → Ra 1,6 [µm] vs. Ra 1,6 [µm] on: <ul style="list-style-type: none"> → Cylindrical_face_01_01 vs. Cylindrical_face_01.01 → Specific tolerance: NO → Coating: NO → Material vs. material: 39NiCrMo3 vs. S 275JR → Type of feature vs. type/s of feature/s: Feature_1 – THREADED CYLINDRICAL PAD (Hex head screw DIN 6921 M12 x 40) vs. Feature_1 – HOLE RECTANGULAR PATTERN_MOD (Column) → Coordinates of the feature vs. coordinates of the feature/s: <ul style="list-style-type: none"> → [00,00;00,00;00,00] vs. [80,00;1010,00;-260,00] → Properties of the feature vs. properties of the feature: <ul style="list-style-type: none"> → Type of thread of Feature_1 – THREADED CYLINDRICAL PAD (Hex head screw DIN 6921 M12 x 40) vs. diameter of Feature_1 - HOLE RECTANGULAR PATTERN_MOD (Column): M12 vs. 13 [mm] → Volume of the feature vs. volume of the feature/s: 3958,41 [mm³] vs. 1327,32 [mm³] → Area of the feature vs. area of the feature/s: 1545,66 [mm²] vs. 673,87 [mm²] → Faces of the feature vs. faces of the feature/s: <ul style="list-style-type: none"> → Cylindrical_face_01.01 vs. Cylindrical_face_01.01 → PMI vs. PMI: <ul style="list-style-type: none"> → Specific roughness: <ul style="list-style-type: none"> → Ra 1,6 [µm] vs. Ra 1,6 [µm] on: <ul style="list-style-type: none"> → Cylindrical_face_01_01 vs. Cylindrical_face_01.01 → Specific tolerance: NO → Coating: NO → Material vs. material: 39NiCrMo3 vs. S 275JR → Type of feature vs. type/s of feature/s: Feature_1 – THREADED CYLINDRICAL PAD (Hex head screw DIN 6921 M12 x 40) vs. Feature_1 – HOLE RECTANGULAR PATTERN_MOD (Arm) → Coordinates of the feature vs. coordinates of the feature/s: <ul style="list-style-type: none"> → [00,00;00,00;00,00] vs. [-80,00;230,00;7,30] → Properties of the feature vs. properties of the feature: <ul style="list-style-type: none"> → Type of thread of Feature_1 – THREADED CYLINDRICAL PAD (Hex head screw DIN 6921 M12 x 40) vs. diameter of Feature_1 - HOLE RECTANGULAR PATTERN_MOD (Arm): M12 vs. 13 [mm] → Volume of the feature vs. volume of the feature/s: 3958,41 [mm³] vs. 1327,32 [mm³] → Area of the feature vs. area of the feature/s: 1545,66 [mm²] vs. 673,87 [mm²] → Faces of the feature vs. faces of the feature/s: <ul style="list-style-type: none"> → Cylindrical face 01.01 vs. Cylindrical face 01.01

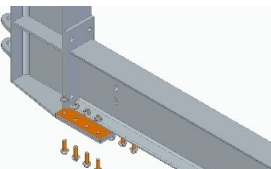
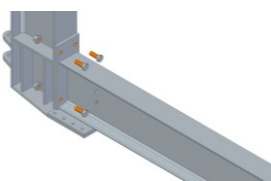
		<ul style="list-style-type: none"> → PMI vs. PMI: <ul style="list-style-type: none"> → Specific roughness: <ul style="list-style-type: none"> → Ra 1,6 [µm] vs. Ra 1,6 [µm] on: <ul style="list-style-type: none"> → Cylindrical_face_01_01 vs. Cylindrical_face_01.01 → Specific tolerance: NO → Coating: NO → Material vs. material: 39NiCrMo3 vs. 39NiCrMo3 → Type of feature vs. type/s of feature/s: Feature_1 – THREADED CYLINDRICAL PAD (Hex head screw DIN 6921 M12 x 40) vs. Feature_1 – THREADED HOLE (Hex nut DIN ISO 6923 M12) → Coordinates of the feature vs. coordinates of the feature/s: <ul style="list-style-type: none"> → [00,00;00,00;00,00] vs. [00,00;00,00;00,00] → Properties of the feature vs. properties of the feature: <ul style="list-style-type: none"> → Type of thread of Feature_1 – THREADED CYLINDRICAL PAD (Hex head screw DIN 6921 M12 x 40) vs. type of thread of Feature_1 – THREADED HOLE (Hex nut DIN ISO 6923 M12): M12 vs. M12 → Volume of the feature vs. volume of the feature/s: 3958,41 [mm³] vs. 1357,17 [mm³] → Area of the feature vs. area of the feature/s: 1545,66 [mm²] vs. 678,58 [mm²] → Faces of the feature vs. faces of the feature/s: <ul style="list-style-type: none"> → Cylindrical_face_01.01 vs. Cylindrical_face_01.01 → PMI vs. PMI: <ul style="list-style-type: none"> → Specific roughness: <ul style="list-style-type: none"> → Ra 1,6 [µm] vs. Ra 1,6 [µm] on: <ul style="list-style-type: none"> → Cylindrical_face_01_01 vs. Cylindrical_face_02.01 → Specific tolerance: NO → Coating: NO
Assembly feature		<ul style="list-style-type: none"> → Material vs. material: 39NiCrMo3 vs. S 275JR → Type of feature vs. type/s of feature/s: Feature_1 – THREADED CYLINDRICAL PAD (Hex head screw DIN 6921 M12 x 40) vs. Feature_3 – RECTANGULAR PAD (Arm) → Coordinates of the feature vs. coordinates of the feature/s: <ul style="list-style-type: none"> → [00,00;00,00;00,00] vs. ([-100,00;230,00;-12,70]; [100,00;230,00;-12,70]; [100,00;230,00;187,30]; [-100,00;230,00;187,30]) → Properties of the feature vs. properties of the feature: <ul style="list-style-type: none"> → Angle between axis of thread of Feature_1 – THREADED CYLINDRICAL PAD (Hex head screw DIN 6921 M12 x 40) vs. Rectangular_face_03.01 and Rectangular_face_03.02 of Feature_3 – RECTANGULAR PAD (Arm): 90,00 [°] → Volume of the feature vs. volume of the feature/s: 3958,41 [mm³] vs. 400000,00 [mm³] → Area of the feature vs. area of the feature/s: 1545,66 [mm²] vs. 88000,00 [mm²] → Faces of the feature vs. faces of the feature/s: <ul style="list-style-type: none"> → Cylindrical_face_01.01 vs. Rectangular_face_03.01 → Cylindrical_face_01.01 vs. Rectangular_face_03.02 → PMI vs. PMI: <ul style="list-style-type: none"> → Specific roughness: <ul style="list-style-type: none"> → Ra 1,6 [µm] vs. Ra 1,6 [µm] on: <ul style="list-style-type: none"> → Cylindrical_face_01_01 vs. Rectangular_face_03.01 → Cylindrical_face_01_01 vs. Rectangular_face_03.02 → Specific tolerance: NO → Coating: NO
Assembly feature		<ul style="list-style-type: none"> → Material vs. material: 39NiCrMo3 vs. S 275JR → Type of feature vs. type/s of feature/s: Feature_1 – CYLINDRICAL PAD (Hex head screw ISO 4018 M16 x 45) vs. Feature_4 – HOLE RECTANGULAR PATTERN (Arm) → Coordinates of the feature vs. coordinates of the feature/s: <ul style="list-style-type: none"> → [00,00;00,00;00,00] vs. [-20,61;-66,17;-12,70] → Properties of the feature vs. properties of the feature: <ul style="list-style-type: none"> → No obstruction in insertion direction Hex head screw ISO 4012 M16 x 45). → Volume of the feature vs. volume of the feature/s: 15263,63 [mm³] vs. 2.463,77 [mm³]

		<ul style="list-style-type: none">→ Area of the feature vs. area of the feature/s: 4389,35 [mm²] vs. 638,37 [mm²]→ Faces of the feature vs. faces of the feature/s:<ul style="list-style-type: none">→ Cylindrical_face_01.01 vs. Cylindrical_face_04.01→ PMI vs. PMI:<ul style="list-style-type: none">→ Specific roughness:<ul style="list-style-type: none">→ No specific roughness vs. Ra 1,6 [μm] on:<ul style="list-style-type: none">→ Rectangular_face_01_01 vs. Cylindrical_face_01.01→ Specific tolerance: NO→ Coating: NO
--	--	--

Appendix B. DfA rules repositories

Table 10: example of DfA repository

Horizontal layer		Vertical layer				Horizontal layer					Guideline
Rule #	Rule type	Assembly Technology		Material		CAD features and algorithms					
		Class	Type – Level	Class	Type	Feature type	CAD features to identify	PMI to read	Parameters	Parameter or threshold to verify	
1	Critical	Manual assembly	Fastening	All materials	N.A.	Assembly feature	Hole Screw	N.A.	Threaded axis direction (A) Plane perpendicular to the threaded axis lean on the head of a threaded element (P)	No obstruction along A direction (+ and -) No obstruction on P plane ($\leq 90^\circ$)	Guarantee tool entrance for threaded elements (screws, bolts, nuts) in the manual assembly process of bolted components
2	Critical	Manual assembly	Fastening	All materials	N.A.	Assembly feature	Hole Screw	N.A.	Hole axis A_h (A_h) Screw axis (A_s) Hole diameter (D_h) Screw diameter (D_s) Diameter gap ($G = D_h - D_s$)	$G \geq f(D_s)$ $A_h = A_s$	Guarantee minimum diameter gap between screw and hole of non-threaded parts in the manual assembly process of bolted components

3	Critical	Manual assembly	Fastening	All materials	N.A.	Assembly feature	Hole Screw	N.A.	Hole axis Ah (Ah) Screw axis (As) Nut axis (An) Threaded hole axis (At)	$As = An = Ah = At$	Keep aligned screw, nut and hole axis in the manual assembly process of bolted components
4	Warning	Manual assembly	Fastening	All materials	N.A.	Assembly feature Geometric feature	Hole Chamfer	N.A.	Threaded hole The chamfer on the threaded hole Hole chamfer Screw chamfer	Chamfer < 1 x 45°	Guarantee chamfered/countersunk insertion holes and chamfered screw ends in the manual assembly process of bolted components
5	Warning	Manual assembly	Fastening	All materials	N.A.	Assembly feature	Hole	N.A.	Hole area (Ah) Threaded hole area (At)	Ah ∩ other circular areas At ∩ other circular areas	Delete non-useful holes and threaded holes in the assembly in the manual assembly process of bolted components
6	Warning	Manual assembly	Fastening	All materials	N.A.	Assembly feature	Fasteners type	N.A.	Screw Washer Nut	N.A.	Prefer the use of combined fasteners in the manual assembly process of bolted components
7	Critical	Manual assembly	Fastening	All materials	N.A.	Assembly feature	Hole	N.A.	Angle between hole axis and surface (α)	$\alpha = 90^\circ$	Guarantee flat surfaces for the insertion holes for screws in the manual assembly process of bolted components
8	Critical	Manual assembly	Fastening	All materials	N.A.	Assembly feature	Hole Screw	N.A.	Diameter of the first screw (Ds) Diameter of the second screw (ds) Distance between the screw axis (La)	$La > 1,2Ds + 1,2ds$	Guarantee minimum distance between the axis of two or more screws in the manual assembly process of bolted components

9	Warning	Manual assembly	Fastening	All materials	N.A.	Assembly feature	Screw	N.A.	Screw type (hex head, cylindrical head, etc.) Diameter of the screw (Ds) Required space volume for clamping tool (V)	$V \geq f(Ds)$	Guarantee access of the clamping tool in the case of threaded elements in the manual assembly process of bolted components
10	Critical	Manual assembly	Fastening	All materials	N.A.	Assembly feature	Screw	N.A.	Lead screw length (Ll) Screw length (Ls)	$Ll > Ls$	Guarantee that the threaded length of the lead screw is greater than the length of the screw to ensure complete tightening of the screw in the manual assembly process of bolted components
11	Information	All types of assemblies	N.A.	All materials	N.A.	Component feature	Dimensions	N.A.	Assembly length (L) Assembly width (W) Assembly height (H)	$L \leq 13,60$ m $W \leq 2,40$ m $H \leq 2,35$ m	Avoid an assembly larger than the limits of a standard articulated unit in case of transport by road
12	Information	All types of assemblies	N.A.	All materials	N.A.	Component feature	Dimensions	N.A.	Assembly length (L) Assembly width (W) Assembly height (H)	$L \leq 12,00$ m $W \leq 2,30$ m $H \leq 2,30$ m	Avoid an assembly larger than the limits of a standard container (high cube) in case of transport by ship
13	Information	All types of assemblies	N.A.	All materials	N.A.	Component feature	Dimensions	N.A.	Assembly length (L) Assembly width (W) Assembly height (H)	$L \leq 6,05$ m $W \leq 2,44$ m $H \leq 2,20$ m	Avoid an assembly larger than the limits of a standard pallet unit in case of transport by plane

14	Warning	Manual assembly	Fastening	All materials	N.A.	Assembly feature	Fasteners	N.A.	Screws Nuts Bolts Snap rings Dowel pins Grease nipples Nails Rivets Tabs Keys	N.A.	Guarantee the accessibility of the connections and elements of an assembly (screws, nuts, bolts, snap rings, dowel pins, grease nipples, nails, rivets, tabs, keys etc.) for assembly and disassembly operations in manual bolted assembly
15	Warning	All types of assemblies	Fastening	All materials	N.A.	Assembly feature	Pin holes	Pin hole tolerance (δ)	Pin hole	$\delta = H7$	Guarantee an H7 tolerance for pin holes in bolted assembly
16	Warning	All types of assemblies	Fastening	All materials	N.A.	Assembly feature	N.A.	Surface 1 roughness ($\mu 1$) Surface 2 roughness ($\mu 2$)	Surface 1 Surface 2	$\mu 1 = \mu 2$	Guarantee the same surface roughness of contact surfaces in bolted assembly
17	Warning	All types of assemblies	Rivetting	All materials	N.A.	Assembly feature	Rivet	N.A.	Plate thickness (t) Distance between rivet axis and plate edge (Lre)	$1,5t < Lre < 8t$	Maintain the correct distance between a rivet and an edge of the plate between in rivetted assembly
18	Warning	All types of assemblies	Rivetting	All materials	N.A.	Assembly feature	Rivet Hole	N.A.	Rivet hole diameter (Dh) Rivet diameter (Dr) Radial clearance (Dh - Dr = δr)	$0,05 Dr < \delta r < 0,07 Dr$	Maintain the correct radial clearance for the rivet hole in the rivetted assembly
19	Warning	All types of assemblies	Rivetting	All materials	N.A.	Assembly feature	Rivet	N.A.	Solid rivet diameter (Dsr)	$Lr < 2 * Dsr$ $0,5 Dstr < Lr$	Guarantee the correct rivet length in rivetted assembly

									Semi-tubular rivet diameter (Dstr) Tubular rivet diameter (Dtr) Rivet length (Lr)	$< 0,7 Dstr$ $Lr < Dtr$	
20	Information	All types of assemblies	N.A.	All materials	N.A.	Assembly feature	Hole	N.A.	Hole	N.A.	Avoid holes in a component if they are not used for assembly and/or operation
21	Information	All types of assemblies	Fastening	All materials	N.A.	Assembly feature	Fasteners type	N.A.	Screw Bolt Nut	N.A.	Avoid using a large variety of different screws/bolts unless necessary in manual bolted assembly
22	Information	Manual assembly	Fastening and Rivetting	All materials	N.A.	Component features	Material type	N.A.	Components material (Mp)	Mc = fragile and/or flexible	Avoid fragile and flexible parts in manual bolted/riveted assembly
23	Information	Manual assembly	N.A.	All materials	N.A.	Component features	Dimensions	N.A.	Components length (Lc) Components width (Wc) Components height (Hc)	$Lc > 5 \text{ mm}$ $Wc > 5 \text{ mm}$ $Hc > 5 \text{ mm}$	Avoid too small parts in manual assembly
24	Information	Manual assembly	N.A.	All materials	N.A.	Component features	Volume Material type	N.A.	Components weight (Wec)	$Wec > 5 \text{ gr}$	Avoid too light part in manual assembly
25	Warning	Manual/automated/robotized assembly	Fastening and Rivetting	All materials	N.A.	Interaction feature	Edge Hole	N.A.	Diameter of screw (Ds) Distance between the screw axis and	$Le > 1,2Ds$	Guarantee the minimum distance between screw hole and component edge in bolted/riveted assembly

									component edge (Le)		
26	Information	Manual assembly	N.A.	All materials	N.A.	Assembly feature	Slot Spring	N.A.	Spring housing	N.A.	Guarantee the housing for the springs in manual assembly
27	Information	Manual assembly	Fastening	All materials	N.A.	Geometric feature	Threaded hole	N.A.	Threaded hole diameter (Dt)	$Dt > M3$	Avoid the use of threaded hole whit a diameter less than M3 in manual bolted assembly
28	Information	All types of assemblies	N.A.	All materials	N.A.	Assembly feature	Bearing	<p>Bearing geometric tolerance shaft side (δ_{gs})</p> <p>Bearing geometric tolerance housing side (δ_{gh})</p> <p>Bearing dimensional tolerance shaft side (δ_{ds})</p> <p>Bearing dimensional tolerance housing side (δ_{gh})</p>	Bearing type (Tb)	$\delta_{gs} = f(Tb)$ $\delta_{gh} = f(Tb)$ $\delta_{ds} = f(Tb)$ $\delta_{ds} = f(Tb)$	Respect dimensional and geometric tolerances for bearing in assembly
29	Information	All types of assemblies	N.A.	All materials	N.A.	Assembly feature	Bearing	Bearing roughness (μ_b)	Bearing type (Tb)	$\mu_b = f(Tb)$	Respect roughness of bearing in assembly

30	Information	All types of assemblies	N.A.	All materials	N.A.	Assembly feature	Bearing	N.A.	Bearing type (Tb)	N.A.	Respect the correct mounting of bearings in assembly
31	Information	All types of assemblies	N.A.	All materials	N.A.	Assembly feature	Bushings	Bushing geometric tolerance shaft side (δ_{gs}) Bushing geometric tolerance housing side (δ_{gh}) Bushing dimensional tolerance shaft side (δ_{ds}) Bushing dimensional tolerance housing side (δ_{dh})	Bushing material type (Mb) Bushing housing material type (Mh)	$\delta_{gs} = f(Mb; Mh)$ $\delta_{gh} = f(Mb; Mh)$ $\delta_{ds} = f(Mb; Mh)$ $\delta_{dh} = f(Mb; Mh)$	Respect dimensional and geometric tolerances for bushings in assembly
32	Information	All types of assemblies	N.A.	All materials	N.A.	Assembly feature	Bushings	Bushing roughness (μ_b)	Bushing material type (Mb) Bushing housing material type (Mh)	$\mu_b = f(Mb; Mh)$	Respect roughness of bushings in assembly

