



UNIVERSITÀ POLITECNICA DELLE MARCHE  
Repository ISTITUZIONALE

A nondegeneracy condition for a semilinear elliptic system and the existence of multibump solutions

This is the peer reviewed version of the following article:

*Original*

A nondegeneracy condition for a semilinear elliptic system and the existence of multibump solutions / Montecchiari, P.; Rabinowitz, P. H.. - In: CALCULUS OF VARIATIONS AND PARTIAL DIFFERENTIAL EQUATIONS. - ISSN 0944-2669. - STAMPA. - 60:4(2021). [10.1007/s00526-021-01987-7]

*Availability:*

This version is available at: 11566/295103 since: 2024-05-31T10:47:57Z

*Publisher:*

*Published*

DOI:10.1007/s00526-021-01987-7

*Terms of use:*

The terms and conditions for the reuse of this version of the manuscript are specified in the publishing policy. The use of copyrighted works requires the consent of the rights' holder (author or publisher). Works made available under a Creative Commons license or a Publisher's custom-made license can be used according to the terms and conditions contained therein. See editor's website for further information and terms and conditions.

This item was downloaded from IRIS Università Politecnica delle Marche (<https://iris.univpm.it>). When citing, please refer to the published version.

(Article begins on next page)

# A nondegeneracy condition for a semilinear elliptic system and the existence of multibump solutions

Piero Montecchiari

Dipartimento di Ingegneria Civile, Edile e Architettura,  
Università Politecnica delle Marche,  
Via brecce bianche, Ancona, I-60131, Italy  
E-mail : p.montecchiari@univpm.it

and

Paul H. Rabinowitz

Department of Mathematics,  
University of Wisconsin-Madison,  
Madison, Wisconsin, 53706, USA  
E-mail: rabinowi@math.wisc.edu

March 4, 2021

## **Abstract**

For a class of semilinear elliptic systems, the existence of a broader class of multibump solutions is established under considerably weaker conditions than in earlier works. The key tool is the use of variational methods.

*Key Words:* semilinear elliptic system, nondegeneracy condition, multibump solutions, mountain pass

*MSC:* Primary: 35J50, 35J47; Secondary: 35J57, 34C37.

# 1 Introduction

Consider the semilinear elliptic system

$$(PDE) \quad -\Delta u + L(x)u = F_u(x, u), \quad x \in \mathbb{R}^n, \quad u \in \mathbb{R}^m,$$

where  $L$  is an  $m$  by  $m$  matrix and  $F_u$  denotes the gradient with respect to the variable  $u$  of a nonlinearity,  $F \geq 0$ . To be more precise about  $L$  and  $F$ , suppose they satisfy the following conditions:

(L)  $L \in C^1(\mathbb{R}^n, \mathbb{R}^m \times \mathbb{R}^m)$ , is 1-periodic in  $x_j$  for  $j = 1, \dots, n$ , and is positive definite for each  $x \in [0, 1]^n$ .

(F1)  $F \in C^2(\mathbb{R}^n \times \mathbb{R}^m, \mathbb{R})$  and  $F(x, u)$  is 1-periodic in  $x_j$  for  $j = 1, \dots, n$ .

(F2) There is a constant,  $C > 0$ , such that

$$|F_{u,u}(x, u)| \equiv \sum_{i,j} |F_{u_i, u_j}(x, u)| \leq C(1 + |u|^{p-1})$$

for any  $x \in \mathbb{R}^n$ ,  $u \in \mathbb{R}^m$ , where  $1 < p < 2_n^* - 1 = \frac{n+2}{n-2}$  if  $n > 2$  while  $p > 1$  for  $n = 1, 2$ .

(F3)  $F_{u,u}(x, 0) = 0$  for any  $x \in \mathbb{R}^n$ .

(F4) There exists a constant,  $\mu > 2$ , such that  $0 < \mu F(x, u) \leq F_u(x, u) \cdot u$  for any  $u \in \mathbb{R}^m \setminus \{0\}$ ,  $x \in \mathbb{R}^n$ .

As a consequence of the conditions on  $F$ , it vanishes more rapidly than quadratically at  $u = 0$  and grows more rapidly than quadratically as  $|u| \rightarrow \infty$ .

Associated with (PDE) is the functional,

$$J(u) = \int_{\mathbb{R}^n} \left( \frac{1}{2} (|\nabla u|^2 + L(x)u \cdot u) - F(x, u) \right) dx.$$

Most of the solutions of (PDE) that we find will be obtained as critical points of  $J$ . By (L), (F1) – (F4),  $J \in C^2(E, \mathbb{R})$  where  $E = W^{1,2}(\mathbb{R}^n, \mathbb{R}^m)$ . Due to (F1), for any  $k \in \mathbb{Z}^n$ ,  $J(u(\cdot + k)) = J(u)$ , i.e.  $J$  has a  $\mathbb{Z}^n$  translational symmetry. In addition, as was shown in [24], (F3) – (F4) imply  $J$  has the geometric structure that allows one to define a minimax value,  $c$ , of mountain pass type. Namely introducing the class of mountain pass curves,

$$H = \{ h \in C([0, 1], E) : h(0) = 0, h(1) \neq 0 \text{ and } J(h(1)) \leq 0 \},$$

the corresponding minimax value is

$$(1.1) \quad c \equiv \inf_{h \in H} \max_{s \in [0,1]} J(h(s)).$$

Conditions (F1) – (F4) are more than adequate to show that (PDE) possesses a solution  $u \neq 0$  as is illustrated by [27] where  $n = 1$  and [29] where  $m = 1$ . In these papers, solutions of (PDE) were obtained by first seeking solutions having a large period in the scalar  $x$  in [27] or in the components of  $x$  in [29]. Then using the Mountain Pass Theorem to obtain critical points of  $J$  in this class of functions, letting the large period(s) go to infinity and passing to a limit with the aid of a priori bounds, yields a solution,  $u$  of (PDE) in  $E$  with  $J(u) \leq c$ . While these arguments provide existence, they do not suffice to show that  $c$  as defined by (1.1) is actually a critical value of  $J$ . However for some special cases of (PDE), it is known that  $c$  is indeed a critical value of  $J$ . This was shown by Jeanjean and Tanaka [15] when the problem is autonomous and by several authors for (PDE) and related equations when a further monotonicity or convexity assumption is made on  $F$  such as :

$$(F5) \quad s^{-1}uF_u(x, su) \text{ is an increasing function of } s > 0 \text{ for all } x \in \mathbb{R}^n \text{ and } u \in \mathbb{R} \setminus \{0\}.$$

or

$$(F6) \quad F_u(x, u)u < F_{u,u}(x, u)u u \text{ for all } x \in \mathbb{R}^n \text{ and } u \in \mathbb{R}^m \setminus \{0\}.$$

See e.g. [25], [9], [14], [28], [3].

To show that  $c$  is a critical value of  $J$  in the full generality of (L), (F1) – (F4), as was proved in [10]-[11], a nondegeneracy condition on the set of critical points of  $J$  suffices. The condition employed in [10]-[11], which goes back to a related condition introduced by Séré [31] in work on homoclinic orbits of first order Hamiltonian systems, is that there is an  $\alpha > 0$  such that the set of critical points of  $J$  with critical values below  $c + \alpha$  (modulo the  $\mathbb{Z}^n$  symmetry mentioned above) is finite. Like [10]-[11], there are other papers that treat simpler versions of (PDE) for Hamiltonian systems ( $n = 1$ ) and a single partial differential equation such as [12], [2], [17], [18], [7], [3] [19], [20], [27], [29] and [33]. They also use variants of the finiteness condition.

The nondegeneracy condition as used in e.g. [10]- [11] played two roles. First it showed  $c$  was a critical value of  $J$  thereby giving us an initial set of

solutions of (PDE). Since these solutions decay to 0 as  $|x| \rightarrow \infty$ , they are so-called 1– bump solutions of the equation. Second it plays a role in an indirect variational argument that in a sense glues the 1–bump mountain pass solutions to construct multibump solutions of (PDE). This leads to existence results of the form: for each  $k \in \mathbb{N}$  with  $k \geq 2$ , there are infinitely many  $k$ -bump solutions that are not merely integer phase shifts of each other. These  $k$ -bump solutions are near (or shadow)  $k$  phase shifts of 1– bump solutions.

A recent paper [24] contains a new nondegeneracy condition that considerably weakens that of [10]-[11] and its variants used in the other quoted papers. Compared to the nondegeneracy condition of [10]- [11], this new condition imposes a mild sort of disconnectedness requirement on the set of critical points of  $J$  with critical values below  $c + \alpha$ . It is the analogue for (PDE) of conditions given to enable the construction of multitransition solutions for various Hamiltonian systems in [30], [20], [8], [23] and for Allen-Cahn type systems of PDEs in [21], [4]. Its precise formulation requires some preparation so it will be postponed until our Section 2.

This new condition provides the analogue of the 1–bump solutions for (PDE) for the current setting. It does not tell us that  $c$  is a critical value of  $J$  but rather that there may merely be a sequence of critical values,  $c_i$ , of  $J$  that approach  $c$  from above. This possibility is due to its analogue in the abstract critical point theorem - see Proposition 2.18 - that we employ to get existence of critical points. Examples show that this phenomenon in which  $c$  is not a critical value can occur in general. Whether it actually must occur here is not yet known. In any event, for any such  $i$ , we find a set of 1–bump solutions - see Theorem 2.19 and Proposition 3.1 - that (modulo the  $\mathbb{Z}^n$  symmetry) is compact rather than finite. This complicates the construction of the multibump solutions.

Another novelty of this work is that in Theorem 3.2, we are able in Corollary 3.3 to find  $k$ –bump solutions for which the distance between the bumps is independent of  $k$ . This is in contrast to [10] - [11] where the distance between the bumps is  $k$  dependent. The additional flexibility provided by our construction enables us to use a limit process to find infinite-bump solutions for which  $J(u) = \infty$ .

The existence of  $k$ -bump homoclinic solutions where the distance between the bumps is independent of  $k$ , and consequently the existence of solutions with infinitely many bumps, was first proved using global variational methods by E. Séré in [23] for first order Hamiltonian systems where the Hamiltonian,

$H(t, z)$  is periodic in  $t$  and convex in  $z$ . Related results were then obtained for second order Hamiltonian systems in [17], [12], [7], [19] under different hypotheses on the time dependence of the Lagrangian. When  $n > 1$ , the situation changes since the geometry of the relative locations of the bumps may be more complicated. A result in this direction is due to Angenent [1] using the contracting mapping theorem. He studied a class of nonlinear elliptic PDEs for which the corresponding functional,  $J$ , had a nondegenerate critical point. Global methods for such a class of PDEs were first used in [18], obtaining solutions with infinitely many bumps provided that each bump was located in a concentric annular region of sufficiently large width, different bumps lying in different such regions. In the present paper the geometric difficulty is overcome by using a suitable partition of  $\mathbb{R}^n$  and employing a multibump construction somewhat related to the ones used in [32], in [17], [18], and in [5], [6]. Thus infinite bump solutions without geometric constraints on the relative locations of the bumps are obtained.

A precise statement and proof of our results will be given in Section 3. In Section 2, several preliminary results from [24] will be recalled. Section 4 contains the rather long and technical construction of a pseudogradient vector field having appropriate properties that plays a crucial role in establishing the main existence assertions of Section 3.

## 2 Preliminary results

This section contains several preliminary results, both notational and otherwise that are needed to prove the main theorems. To begin observe that as a consequence of (F2) – (F4), for any  $\epsilon > 0$ , there is a constant,  $C_\epsilon > 0$  such that

$$(2.1) \quad \begin{aligned} |F(x, u)| &\leq \frac{\epsilon}{2}|u|^2 + \frac{C_\epsilon}{p+1}|u|^{p+1}, \\ |F_u(x, u)| &\leq \epsilon|u| + C_\epsilon|u|^p, \text{ and} \\ |F_{uu}(x, u)| &\leq \epsilon + pC_\epsilon|u|^{p-1} \text{ for all } (x, u) \in \mathbb{R}^n \times \mathbb{R}^m. \end{aligned}$$

Since the proof is essentially the same, to simplify matters in what follows,  $L$  is taken to be the identity matrix. The space  $E$  is a Hilbert space with scalar product

$$\langle u, v \rangle \equiv \langle u, v \rangle_{W^{1,2}(\mathbb{R}^n, \mathbb{R}^m)} \equiv \sum_{\iota=1}^m \int_{\mathbb{R}^n} (\nabla u_\iota(x) \cdot \nabla v_\iota(x) + u_\iota(x)v_\iota(x)) dx.$$

and norm

$$\|u\|^2 = \langle u, u \rangle = \sum_{\iota=1}^m \int_{\mathbb{R}^n} (|\nabla u_\iota|^2 + |u_\iota|^2) dx.$$

Above  $\nabla u_\iota(x) \cdot \nabla v_\iota(x)$  denotes the scalar product in  $\mathbb{R}^n$  of the two vectors  $\nabla u_\iota(x)$  and  $\nabla v_\iota(x)$ :  $\nabla u_\iota(x) \cdot \nabla v_\iota(x) = \sum_{i=1}^n \partial_i u_\iota(x) \partial_i v_\iota(x)$ . Using the notation

$$|\nabla u(x)|^2 = \sum_{\iota=1}^m |\nabla u_\iota(x)|^2$$

the norm can be written more concisely as

$$\|u\|^2 = \int_{\mathbb{R}^n} (|\nabla u(x)|^2 + |u(x)|^2) dx.$$

For future reference, for any measurable  $\Omega \subset \mathbb{R}^n$  and  $u, v \in E$ , we set

$$\begin{aligned} \langle u, v \rangle_\Omega &\equiv \langle u, v \rangle_{W^{1,2}(\Omega, \mathbb{R}^m)} \equiv \sum_{\iota=1}^m \int_{\Omega} (\nabla u_\iota(x) \cdot \nabla v_\iota(x) + u_\iota(x) v_\iota(x)) dx, \\ \|u\|_\Omega^2 &\equiv \int_{\Omega} (|\nabla u(x)|^2 + |u(x)|^2) dx. \end{aligned}$$

The functional  $J$  can be written as

$$J(u) = \frac{1}{2} \|u\|^2 - \int_{\mathbb{R}^n} F(x, u) dx, \quad u \in E.$$

The assumptions on  $F$  are more than sufficient to show that  $J \in C^1(E)$  with

$$J'(u)v = \langle u, v \rangle - \int_{\mathbb{R}^n} F_u(x, u)v dx, \quad u, v \in E,$$

where, for (a.e.)  $x \in \mathbb{R}^n$ ,

$$F_u(x, u(x))v(x) = \sum_{\iota=1}^m F_{u_\iota}(x, u(x))v_\iota(x).$$

Now several results obtained in [24] will be recalled. It follows from the properties of  $F$  and the form of  $J$  that  $J$  satisfies the geometrical hypotheses of the Mountain Pass Theorem and in particular that there is a  $\rho \in (0, 1)$  such that if  $u \in E$  satisfies  $\|u\| \leq \rho$ , then

$$(2.2) \quad J(u) \geq \frac{1}{4} \|u\|^2 \text{ and } J'(u)u \geq \frac{1}{2} \|u\|^2.$$

Thus by (2.2), defining the class of mountain pass curves,  $H$ , as in the Introduction,

$$(2.3) \quad c \equiv \inf_{h \in H} \max_{s \in [0,1]} J(h(s)) \geq \frac{1}{4}\rho^2.$$

Set

$$\mathcal{D} = \{u \in E \setminus \{0\} \mid J'(u) = 0\}$$

and

$$T_k = [k_1, k_1 + 1] \times \dots \times [k_n, k_n + 1] \text{ for } k \in \mathbb{Z}^n.$$

Then from [24],

**Lemma 2.4.** *There exists a  $\bar{\rho} \in (0, \rho/2)$  such that if  $u, v \in E$ , then*

$$(2.5) \quad \int_{\mathbb{R}^n} |F_u(x, u)v| dx \leq \frac{1}{2}\|u\|\|v\| \text{ whenever } \sup_{k \in \mathbb{Z}^n} \|u\|_{T_k} \leq 2\bar{\rho}.$$

Moreover

$$(2.6) \quad \max_{k \in \mathbb{Z}^n} \|u\|_{T_k} > 2\bar{\rho} \text{ for any } u \in \mathcal{D} \text{ and } \inf_{u \in \mathcal{D}} J(u) \geq \frac{\mu-2}{\mu}\bar{\rho}.$$

**Remark 2.7.** Some localized versions of (2.5) will be needed later. Towards that end, let  $\Omega$  be a measurable set of  $\mathbb{R}^n$  which satisfies the cone property with respect to the right-spherical cone

$$\mathcal{T} = \{\lambda x \mid \lambda \in [0, 1], x \in \partial B_{1/2}(0), x_1 > 1/4\}.$$

Due to this uniformity, for any such  $\Omega$ , there is a constant,  $\kappa > 0$  depending on  $\mathcal{T}$  but independent of  $\Omega$  such that  $\|u\|_{L^{p+1}(\Omega, \mathbb{R}^m)} \leq \kappa\|u\|_{\Omega}$  for all  $u \in E$ . Further requiring that  $\bar{\rho}$  satisfies

$$(2.8) \quad C_{1/4}\kappa^{p+1}(2\bar{\rho})^{p-1} \leq 1/4,$$

the argument which leads to (2.11) in [24] shows that this choice of  $\bar{\rho}$  implies that if  $\|u\|_{\Omega} \leq 2\bar{\rho}$  and  $v \in E$ , then

$$(2.9) \quad \int_{\Omega} F(x, u) dx \leq \frac{1}{4}\|u\|_{\Omega}^2 \text{ and } \int_{\Omega} |F_u(x, u)v| dx \leq \frac{1}{2}\|u\|_{\Omega}\|v\|_{\Omega}.$$

The next result, a restatement of Proposition 2.22 of [24], provides us with a compactness property of  $J$ :

**Proposition 2.10.** *Let  $(u_p) \subset E$  be such that  $J(u_p) \rightarrow b$ ,  $J'(u_p) \rightarrow 0$  as  $p \rightarrow \infty$ . Suppose there exists an  $R > 0$  independent of  $p$  such that*

$$(2.11) \quad \|u_p\|_{T_q} < 2\bar{\rho}$$

*whenever  $q \in \mathbb{Z}^n$  with  $\max_{1 \leq i \leq n} |q_i| \geq R$ . Then there is  $U_0 \in \{0\} \cup \mathcal{D} \cap \{J \leq b\}$  such that, up to a subsequence,  $u_p \rightarrow U_0$  in  $E$  as  $p \rightarrow \infty$ .*

Towards formulating the nondegeneracy condition that we will use, for  $d > 0$ , set  $\mathcal{D}^d \equiv \mathcal{D} \cap \{J \leq d\}$ , define

$$\mathcal{S}^d \equiv \{U|_{T_0} \mid U \in \mathcal{D}^d\}.$$

Thus if  $u \in \mathcal{S}^d$ ,  $u$  is the restriction to  $T_0$  of a critical point  $U \neq 0$  of  $J$  such that  $J(U) \leq d$ . Some important properties of  $\mathcal{S}^d$  are

**Proposition 2.12.** *1<sup>o</sup> the map  $u \in \mathcal{S}^d \rightarrow U \in \mathcal{D}^d$  is invertible.*

*2<sup>o</sup>  $\overline{\mathcal{S}^d} = \mathcal{S}^d \cup \{0\}$  is a compact metric space under the metric obtained from  $\|\cdot\|_{W^{1,2}(T_0, \mathbb{R}^m)}$ .*

Let  $(e_1, \dots, e_n)$  denote the canonical orthonormal base of  $\mathbb{R}^n$ . For  $\ell \in \{1, \dots, n\}$ , consider the shift map

$$g_\ell : \overline{\mathcal{S}^d} \rightarrow \overline{\mathcal{S}^d}, \quad g_\ell(U|_{T_0}) = U(\cdot + e_\ell)|_{T_0}.$$

More generally, letting

$$g^k \equiv g_1^{k_1} \circ \dots \circ g_n^{k_n} \text{ for } k = (k_1, \dots, k_n) \in \mathbb{Z}^n,$$

$g^k$  is a homeomorphism on  $\overline{\mathcal{S}^d}$  with  $g^k(0) = 0$  for any  $k \in \mathbb{Z}^n$ . Note that for  $u \in \mathcal{S}^d$ ,

$$(2.13) \quad g^k(u) \rightarrow 0 \text{ in } W^{1,2}(T_0, \mathbb{R}^m) \text{ as } |k| \rightarrow \infty.$$

Moreover by (2.6), for any  $u \in \mathcal{S}^d$ , there exists a  $q(u) = (q_1(u), \dots, q_n(u)) \in \mathbb{Z}^n$  such that

$$(2.14) \quad \|g^{q(u)}(u)\|_{W^{1,2}(T_0, \mathbb{R}^m)} > 2\bar{\rho}.$$

Set

$$\mathcal{R}^d = \{u \in \overline{\mathcal{S}^d} \mid \|u\|_{W^{1,2}(T_0, \mathbb{R}^m)} \geq 2\bar{\rho}\}.$$

The set  $\mathcal{R}^d$  is a compact subset of  $\overline{\mathcal{S}^d}$  and  $0 \notin \mathcal{R}^d$ . Moreover whenever  $u \in \mathcal{S}^d$ , any “trajectory”  $\{g^k(u) \mid k \in \mathbb{Z}^n\}$  intersects  $\mathcal{R}^d$  since by (2.14):

$$(2.15) \quad g^{q(u)}(u) \in \mathcal{R}^d \text{ for any } u \in \mathcal{S}^d.$$

Let  $\mathcal{C}^d(0)$  denote the component to which 0 belongs in  $\overline{\mathcal{S}^d}$ . Since  $g^k$  is a homeomorphism on  $\overline{\mathcal{S}^d}$ , for any  $k \in \mathbb{Z}^n$ ,  $g^k(\mathcal{C}^d(0))$  is compact, connected and contains 0. Hence

$$g^k(\mathcal{C}^d(0)) \subset \mathcal{C}^d(0) \text{ for any } k \in \mathbb{Z}^n.$$

In particular

$$(2.16) \quad \text{if } u \in \mathcal{C}^d(0) \setminus \{0\}, \text{ then } g^k(u) \in \mathcal{C}^d(0) \setminus \{0\} \text{ for any } k \in \mathbb{Z}^n.$$

By (2.15) and (2.16), either

$$(2.17) \quad (1^\circ) \mathcal{C}^d(0) = \{0\} \text{ or } (2^\circ) \mathcal{R}^d \cap \mathcal{C}^d(0) \neq \emptyset.$$

Our nondegeneracy condition is that  $(1^\circ)$  of (2.17) holds. When this is the case, classical topological separation theorems imply  $\overline{\mathcal{S}^d}$  can be split into the disjoint union of two compact sets  $K_1$  and  $K_2$ , one containing 0 and the other  $\mathcal{R}^d$ . More precisely

- i)  $\overline{\mathcal{S}^d} = K_1 \cup K_2$  and  $K_1 \cap K_2 = \emptyset$ ,
- ii)  $0 \in K_1$ ,  $\mathcal{R}^d \subset K_2$ ,
- iii)  $K_1 \neq \{0\}$ ,  $K_1$  and  $K_2$  are non-empty and compact in  $W^{1,2}(T_0, \mathbb{R}^m)$ .

This decomposition of  $\overline{\mathcal{S}^d}$  is not unique but it can be assumed that

$$\text{iv) } \|u\|_{W^{1,2}(T_0, \mathbb{R}^m)} \leq \bar{\rho}/2 \text{ for any } u \in K_1.$$

Choose  $r_0 \in (0, \bar{\rho}/2)$  such that

$$\text{v) } \|K_1 - K_2\|_{W^{1,2}(T_0, \mathbb{R}^m)} \geq 5r_0.$$

The next abstract result, first obtained in [22], is the existence tool used to get the basic solutions of (PDE) in [24].

**Proposition 2.18.** *Let  $E$  be a real Hilbert space and  $J : E \rightarrow \mathbb{R}$ . Let  $e_0 \neq e_1 \in E$  and define*

$$\Gamma \equiv \{\gamma \in C([0, 1], E) \mid \gamma(0) = e_0, \gamma(1) = e_1\},$$

*Assume*

$$(J_1) \ J \in C^1(E, \mathbb{R}).$$

$$(J_2) \ b = \inf_{\gamma \in \Gamma} \max_{s \in [0, 1]} J(\gamma(s)) > \max\{J(e_0), J(e_1)\}.$$

$(J_3)$  *There are constants,  $b^* > b$ ,  $\nu > 0$ ,  $r^* > 0$  and a sequence,  $(\mathcal{A}_j)_{j \in \mathbb{Z}}$  of disjoint subsets of  $E$  such that*

$$(i) \ \mathcal{A} \equiv \{u \in E \mid \|J'(u)\| \leq \nu, J(u) \leq b^*\} \subset \cup_{j \in \mathbb{Z}} \mathcal{A}_j,$$

$$(ii) \ \|\mathcal{A}_i - \mathcal{A}_j\| \geq 3r^* \text{ if } i \neq j,$$

$(iii)$  *The Palais- Smale condition (or (PS) for short) holds in  $\mathcal{A}_j$  for each  $j \in \mathbb{Z}$ , i.e. if  $(u_k)$  is a sequence in  $\mathcal{A}_j$  with  $J(u_k)$  bounded and  $J'(u_k) \rightarrow 0$ , then  $u_k$  has a convergent subsequence in  $\mathcal{A}_j$ .*

*Then for any  $\varepsilon > 0$ ,  $J$  possesses a critical value  $b_\varepsilon \in [b, b + \varepsilon)$  and a critical point,  $u_\varepsilon$ , with  $J(u_\varepsilon) = b_\varepsilon$ . Moreover  $u_\varepsilon$  is not a local minimum of  $J$ .*

Proposition 2.18 implies the main theorem of [24]:

**Theorem 2.19.** *Suppose that (L), (F1) – (F4) are satisfied and  $c$  is defined by (2.3). Let  $d > c$  and assume  $1^\circ$  of (2.17) holds. Then for any  $\varepsilon > 0$ ,  $J$  possesses a critical point,  $U_\varepsilon \in E$ , such that  $J(U_\varepsilon) \in [c, c + \varepsilon)$ .*

**Remark 2.20.** As was shown in [24], when the nondegeneracy condition of [10] - [12] is satisfied, in fact  $c$  is a critical value of  $J$ .

That the critical points of  $J$  in  $E$  are classical solutions of (PDE) is a straightforward consequence of elliptic regularity theory:

**Proposition 2.21.** *Let (L), (F1) – (F4) be satisfied and suppose that  $U \in W_{loc}^{1,2}(\mathbb{R}^n, \mathbb{R}^m)$  is a weak solution of (PDE), i.e. for all  $\phi \in C_0^\infty(\mathbb{R}^n, \mathbb{R}^m)$ ,*

$$(2.22) \quad \langle U, \varphi \rangle - \int_{\mathbb{R}^n} F_u(x, U) \varphi \, dx = 0.$$

Then  $U \in C_{loc}^{2,\alpha}(\mathbb{R}^n)$  for any  $\alpha \in (0, 1)$  and is a classical solution of (PDE). In particular this is true for any critical point,  $U \in E$  of  $J$ .

**Proof:** If  $U$  is a weak solution of (PDE), we will show that  $U \in C_{loc}^{2,\alpha}(\mathbb{R}^n, \mathbb{R}^m)$  for any  $\alpha \in (0, 1)$ . Suppose first that  $m = 1$ , i.e.  $U$  is a scalar function. Let  $\zeta \in C(\mathbb{R}^n, [0, 1])$  with  $\zeta$  smooth,  $\zeta(x) = 1$  for  $|x| \leq R_0$  and  $\zeta(x) = 0$  for  $|x| \geq R_0 + 1$ . If  $U$  were a solution of (PDE), then for all  $x \in \mathbb{R}^n$ ,

$$L_0(\zeta U) \equiv -\Delta(\zeta U) + \zeta U = -(\Delta\zeta)U - 2\nabla\zeta \cdot \nabla U + \zeta F_u(x, U) \equiv f(x),$$

where by (F2),  $f \in L^p(B_{R_0+1}(0))$  for some  $p > 1$  with  $p$  independent of  $R_0$ . Consider the boundary value problem

$$(2.23) \quad L_0 v = f, \quad x \in B_{R_0+1}(0), \quad v = 0 \text{ on } \partial B_{R_0+1}.$$

By Theorem 9.15 of [13], there is a unique solution,  $v \in W^{2,p}(B_{R_0+1}(0)) \cap W_0^{1,p}(B_{R_0+1}(0))$  of (2.23). We claim  $v = \zeta U$ . Assuming this for the moment, then  $U$  is a strong solution of (PDE) in  $B_{R_0}(0)$ . This additional regularity of  $U$ , the fact that  $R_0$  is arbitrary, and a bootstrap argument as e.g. in Section 5 of [11] show  $U \in C_{loc}^{2,\alpha}(\mathbb{R}^n, \mathbb{R})$  and is a classical solution of (PDE).

To verify that  $v = \zeta U$ , note first that  $v$  is a weak solution of (2.23): for all smooth  $\varphi$  with support in  $B_{R_0+1}(0)$ ,

$$(2.24) \quad \int_{\mathbb{R}^n} (\nabla v \cdot \nabla \varphi + v \varphi) \, dx = \int_{\mathbb{R}^n} f \varphi \, dx.$$

Since this weak solution is unique, it suffices to show that  $\zeta U$  is also a weak solution of (2.24). Replacing  $v$  by  $\zeta U$  in the left hand side of (2.24) gives

$$\int_{\mathbb{R}^n} (\zeta \nabla U \cdot \nabla \varphi + U \nabla \zeta \cdot \nabla \varphi + \zeta U \varphi) \, dx$$

while after an integration by parts and using (2.22), the right hand side becomes

$$\int_{\mathbb{R}^n} (\nabla \zeta \cdot (U \nabla \varphi + \varphi \nabla U) - 2\varphi (\nabla \zeta \cdot \nabla U) + \zeta \nabla U \cdot \nabla \varphi + \varphi \nabla U \cdot \nabla \zeta + U \zeta \varphi) \, dx.$$

Thus the two sides are equal and the case of  $m = 1$  is proved.

Next suppose that  $m > 1$ . Then  $U = (U_1, \dots, U_m)$  and each component,  $F_i$ , of  $F$  satisfies

$$(2.25) \quad \langle U_i, \varphi \rangle - \int_{\mathbb{R}^n} F_{i,u}(x, U) \varphi \, dx = 0.$$

Thus with  $\zeta$  as earlier, the argument just given shows  $\zeta U_i \in W^{2,p}(B_{R_0+1}(0))$ , for  $1 \leq i \leq n$  and again a bootstrap argument and that  $R_0$  is arbitrary yield  $U \in C_{loc}^{2,\alpha}(\mathbb{R}^n, \mathbb{R}^m)$ . Lastly any critical point of  $J$  in  $E$  is a weak solution of (PDE).

**Remark 2.26.** While the content of Theorem 2.19 sufficed for the purposes of [24], further information about the nature of the topology of the level sets of  $J$  near  $J(U_\varepsilon)$  is required to construct the multibump solutions of (PDE) that are of concern here. This information will be provided at the beginning of the next section.

To conclude this section, it is necessary for our multibump construction to make more precise the relationship between Proposition 2.18 and Theorem 2.19. To apply the former to the latter, set  $e_0 = 0$  and choose  $v \in E \setminus \{0\}$ . Then if  $s \in \mathbb{R}$  is large and  $e_1 = sv$ , we see that  $J(e_1) < 0$ . In particular, it can be assumed that  $\|e_1\| > \rho$  with  $\rho$  as chosen prior to (2.2). Then  $\gamma([0, 1]) \cap \partial B_\rho(0) \neq \emptyset$  for each  $\gamma \in \Gamma$ , from which it follows that  $J$  satisfies  $(J_2)$  with  $b = c$ .

To describe what the sets,  $\mathcal{A}_j$ , of Proposition 2.18 are in the setting of Theorem 2.19, let  $k^1, k^2 \in \mathbb{Z}^n$ . Then by  $k^1 \prec k^2$ , we mean that  $k_\ell^1 < k_\ell^2$  for each  $\ell \in \{1, \dots, n\}$ . Let  $d > c$  be such that  $1^\circ$  of (2.17) holds and let  $k^-, k^+ \in \mathbb{Z}^n$  with  $k^- \prec k^+$ . Define

$$\mathcal{A}_{k^-, k^+}^d = \{U \in E \mid U \text{ satisfies (A1) - (A3)}\}$$

where

$$(A1) \quad J(U) \leq d,$$

$$(A2) \quad \text{if } k_\ell \geq k_\ell^+ \text{ or } k_\ell \leq k_\ell^- \text{ for some } \ell \in \{1, \dots, n\}, \text{ then } \|g^k(U|_{T_0}) - K_1\|_{T_0} \leq r_0,$$

$$(A3) \quad \text{for each } \ell \in \{1, \dots, n\}, \quad k_\ell^{-,\ell} \equiv k_\ell^- + 1, \quad k_\ell^{+,\ell} \equiv k_\ell^+ - 1 \text{ satisfy}$$

$$\|g^{k^{-,\ell}}(U|_{T_0}) - K_2\|_{T_0} \leq r_0, \quad \|g^{k^{+,\ell}}(U|_{T_0}) - K_2\|_{T_0} \leq r_0.$$

Then the family of sets  $\{\mathcal{A}_j \mid j \in \mathbb{Z}\}$  correspond to the sets

$$\{\mathcal{A}_{k^-,k^+}^d \mid k^-, k^+ \in \mathbb{Z}^n \text{ and } k^- \prec k^+\}.$$

More precisely, as proved in [24], the sets  $\mathcal{A}_{k^-,k^+}^d$  satisfy  $(J_3)$  with  $b^* = d$ ,  $r^* = r_0/3$  and  $\nu$  sufficiently small. Henceforth we set  $r^* = r_0/3$ .

Having these preliminaries, the question of constructing multibump solutions of (PDE) will be studied in the next section.

### 3 Gluing basic mountain pass solutions

This section contains our main result, Theorem 3.2, on the existence of so-called multibump solutions of (PDE). These solutions are obtained by a variational argument using the basic mountain pass solutions of (PDE) provided by Proposition 2.18. This Proposition was proved in [22]. Its proof uses a deformation argument based on property  $(J_3)$ . For each  $\epsilon > 0$ ,  $(J_3)$  enables us to reduce the search for critical points of  $J$  from all of  $E$  to one of the sets,  $\mathcal{A}_j$ . In this  $\mathcal{A}_j$ , we then find that a local mountain pass geometry is present at a level  $\bar{c} \in [c, c + \epsilon)$ . Since the (PS) property holds in each of these sets, the existence of a critical point,  $U_\epsilon$ , as stated in Theorem 2.19 obtains via a mountain pass argument. Moreover the proof of Proposition 5.7 in [22] yields some useful local properties of the topology of the level sets of the functional  $J$  near  $\bar{c}$ . These properties are essential for our construction of the multibump solutions of (PDE) and are collected in the next proposition. First some notation: for  $s \in \mathbb{R}$ , let  $J^s = \{u \in E \mid J(u) < s\}$  so  $\bar{J}^s \subset \{u \in E \mid J(u) \leq s\}$ . In what follows,  $B_s(x)$  denotes an open ball of radius  $s$  about  $x$ . Analogously, if  $A$  is any set, then  $B_s(A) = \{x \mid \text{dist}(x, A) < s\}$ . The underlying space will be clear from the context.

**Proposition 3.1.** *Suppose that (L), (F1)–(F4) are satisfied and  $c$  is defined by (2.3). Let  $d > c$  and assume  $1^\circ$  of (2.17) holds. Then for any  $\epsilon \in (0, d - c)$ , there exists a  $\bar{c} \in [c, c + \epsilon)$ ,  $j \in \mathbb{N}$ , and a nonempty compact set,  $\mathcal{K}_{\bar{c}} \subset \mathcal{A}_j$ , of critical points of  $J$  having critical value  $\bar{c}$ . Moreover for  $r^*$  as in  $(J_3)$ ,  $\mathcal{K}_{\bar{c}}$  has the property that for each  $r \in (0, r^*/10)$ , there is a  $\lambda(r) \in (0, (d - \bar{c})/4)$  such that*

- (A) *whenever  $u \in B_{10r}(\mathcal{K}_{\bar{c}}) \setminus B_r(\mathcal{K}_{\bar{c}})$  and  $\bar{c} - 2\lambda(r) < J(u) < \bar{c} + 2\lambda(r)$ , then there exists a  $\mu_r > 0$  (with  $\mu_r$  independent of  $u$ ) such that  $\|J'(u)\| \geq 2\mu_r$ , and*

(B) whenever  $h \in (0, \lambda(r))$ , then there exists a pair of points  $u_0(r, h)$ ,  $u_1(r, h)$  on  $\partial B_{4r}(\mathcal{K}_{\bar{c}})$  and a path  $\gamma_{r,h} \in C([0, 1], W^{1,2}(\mathbb{R}^n, \mathbb{R}^m))$  joining  $u_0(r, h)$  and  $u_1(r, h)$  satisfying:

- (i)  $u_0(r, h), u_1(r, h) \in J^{\bar{c}-h}$ ;
- (ii)  $u_0(r, h)$  and  $u_1(r, h)$  are not path connectible in  $B_{r^*}(\mathcal{K}_{\bar{c}}) \cap J^{\bar{c}}$ ;
- (iii)  $\gamma_{r,h}([0, 1]) \subset \bar{B}_{4r}(\mathcal{K}_{\bar{c}}) \cap J^{\bar{c}+h}$ ;
- (iv) if  $\text{dist}_E(\gamma_{r,h}(\theta), \mathcal{K}_{\bar{c}}) > 3r$ , then  $\gamma_{r,h}(\theta) \in J^{\bar{c}-h}$ .

The goal of the present section is to use the properties stated in Proposition 3.1 to show that when the set of critical points of  $J$  with critical values near  $c$  is not too degenerate, there are infinitely many other so-called multi-bump solutions of (PDE). As in earlier works, for each  $k \in \mathbb{N}$ , new  $k$ -bump solutions are obtained by variationally gluing  $k$  different phase shifts of the set of one-bump solutions of Theorem 2.19 or more properly phase shifts of the compact set,  $\mathcal{K}_{\bar{c}}$ , given by Proposition 3.1. Moreover the Proposition provides the topological properties required for our minimax construction to succeed for any  $k \in \mathbb{N}$ . The existence argument is an adaption to the present setting of some of the ideas originally developed in [31], [10], [32] for ODE systems and in [11], [18] for (PDE) when  $m = 1$ . The current setting differs from these earlier papers in that the set  $\mathcal{K}_{\bar{c}}$  here is merely compact and this leads to a more complicated construction than in the cases previously studied. In addition, as was noted earlier, unlike the previous papers on (PDE) when  $n > 1$ , our construction allows us to obtain the existence of “ $k$  bump solutions”, whenever the (appropriately measured) distance between the 1-bump solutions is sufficiently large, independently of the choice of  $k \in \mathbb{N}$ . Consequently by limit arguments, this result gives the existence of infinite-bump solutions to (PDE).

For a set  $X \subset E$  and  $q \in \mathbb{Z}^n$ , let  $f_q(X) = \{u(\cdot - q) \mid u \in X\}$ . Now our main result can be stated:

**Theorem 3.2.** *Suppose that (L), (F1) – (F4) are satisfied and  $c$  is defined by (2.3). Let  $d > c$  and assume 1<sup>o</sup> of (2.17) holds. Let  $\bar{c}$  and  $K \equiv \mathcal{K}_{\bar{c}}$  be given by Proposition 3.1. Then one of the following two alternatives occurs:*

- (i) *there exist  $a < b \in \mathbb{R}$  such that  $\bar{c} \in [a, b]$  and for any  $s \in [a, b]$  there is a  $U_s \in B_{r^*}(K)$  such that  $J(U_s) = s$  and  $J'(U_s) = 0$ ;*

(ii) for any  $\delta > 0$ , there exists an  $\bar{\mathcal{L}} = \bar{\mathcal{L}}(\delta) > 0$  such that for any given  $k \in \mathbb{N}$  with  $k \geq 2$ , and set of points,  $\xi^1, \dots, \xi^k \in \mathbb{Z}^n$  satisfying  $|\xi^j - \xi^i| > 3\bar{\mathcal{L}}$  when  $i \neq j$ , there is a solution  $U \in E$  of (PDE) such that

- 1)  $\|U - f_{\xi^j}(K)\|_{B_{\bar{\mathcal{L}}}(\xi^j)} < \delta$  for each  $j \in \{1, \dots, k\}$ , and
- 2)  $\|U\|_{B_{\bar{\mathcal{L}}}(x) \setminus (\cup_{j=1}^k B_{\bar{\mathcal{L}}}(\xi^j))} < \delta$  for each  $x \in \mathbb{R}^n$ .

For either case,  $J$  has infinitely many distinct critical values.

Thus Theorem 3.2 tells us that either the set of critical values of  $J$  near  $\bar{c}$  is highly degenerate in the sense of (i) or one can construct infinitely many multibump solutions of (PDE) as in (ii). By (ii-1), the solution  $U$  is close to  $f_{\xi^j}(K)$  on  $B_{\bar{\mathcal{L}}}(\xi^j)$  for any  $j \in \{1, \dots, k\}$  while it is near 0 outside of  $\cup_{j=1}^k B_{\bar{\mathcal{L}}}(\xi^j)$  in the sense of (ii-2). When (i) fails, fixing any sequence of points  $(\xi^i)_{i \in \mathbb{N}}$  in  $\mathbb{Z}^n$  such that  $|\xi^j - \xi^i| > 3\bar{\mathcal{L}}$  when  $i \neq j$ , for any  $k \in \mathbb{N}$  there is a solution  $U_k$  of (PDE) satisfying (ii-1) and (ii-2) with respect to the points  $\{\xi_1, \dots, \xi_k\}$ . Then, a limit procedure gives the existence of solution to (PDE) having infinitely many bumps. The next result states this more precisely.

**Corollary 3.3.** *Suppose alternative (ii) of Theorem 3.2 occurs. Then for any  $\delta > 0$ ,  $\bar{\mathcal{L}}$  as in (ii), and sequence of points  $(\xi^i)_{i \in \mathbb{N}}$  in  $\mathbb{Z}^n$  satisfying  $|\xi^j - \xi^i| > 3\bar{\mathcal{L}}$  when  $i \neq j$ , there is a solution  $U \in C_{loc}^{2,\alpha}(\mathbb{R}^n)$  of (PDE) for each  $\alpha \in (0, 1)$  such that*

- 1)  $\|U - f_{\xi^j}(K)\|_{B_{\bar{\mathcal{L}}}(\xi^j)} \leq \delta$  for each  $j \in \mathbb{N}$ , and
- 2)  $\|U\|_{B_{\bar{\mathcal{L}}}(x) \setminus (\cup_{j \in \mathbb{N}} B_{\bar{\mathcal{L}}}(\xi^j))} \leq \delta$  for each  $x \in \mathbb{R}^n$ .

The Corollary will be proved at the end of this section.

Parameters play an important role in the proof of Theorem 3.2. Therefore it is necessary to keep careful track of them. Towards that end, let  $\delta \in (0, r^*/20)$  and  $r \in (0, \delta/(3^n \cdot 20))$ . Recall that  $r^* = r_0/3$ . The parameter  $\bar{\rho}$  was introduced in Lemma 2.4 ( $\bar{\rho} < \rho/2$  and from earlier,  $\rho \in (0, 1)$ ) and further restricted by Remark 2.7. Lastly  $r_0 \in (0, \bar{\rho}/2)$  was introduced in v) just above Proposition 2.18. Combining these observations yields

$$(3.4) \quad r < \delta/(3^n \cdot 20) < r^*/(3^n \cdot 400) = r_0/(3^n \cdot 1200) < \bar{\rho}/(3^n \cdot 2400)$$

and also imply  $\delta < 1$ . Next set

$$(3.5) \quad r_1 = 3r + r/8, \quad r_2 = 3r + r/4, \quad r_3 = 4r - r/8.$$

To prove Theorem 3.2, it will be shown that if the strongly degenerate case (i) does not occur, then the variational glueing provided by (ii) takes place. Note that to verify (ii), it suffices to do so for small  $\delta$  as will be done here. The proof of the Theorem requires several preliminary steps and is rather long and technical. Therefore it is useful to begin by briefly outlining some of the steps.

**Step 1** : Show that the failure of (i) leads to an estimate in condition  $(P_1)$  below that will be useful in Step 4.

**Step 2** : The construction of a finite partition,  $\mathcal{U}(\xi, \mathcal{L})$ , of  $\mathbb{R}^n$  that will enable us to control the bumps. The properties of  $\mathcal{U}(\xi, \mathcal{L})$  are given in Proposition 3.10.

**Step 3** : The partition is used to define a family of neighborhoods,  $\mathcal{B}(\bar{r}, \xi, K)$ , involving phase shifts of the set of critical points,  $K$ , that was introduced in the statement of Theorem 3.2. These neighborhoods satisfy 1) and 2) of (ii) of Theorem 3.2. The shadowing solutions of (PDE) that we seek will be found as critical points of  $J$  in  $\mathcal{B}$  for an appropriate choice of  $\bar{r}$  and  $\xi = (\xi_1, \dots, \xi_k)$ .

**Step 4** : A key step in showing that  $J$  has a critical point in  $\mathcal{B}$  for an appropriate choice of  $\bar{r}$  is the construction in Proposition 3.14 of a pseudogradient or p.g. vector field,  $\mathcal{V}$ , for  $J$  in  $\mathcal{B}$ . This is the most lengthy and technical part of the argument and its proof will be given in Section 4. The p.g. construction goes back to the work by Séré [32] as adapted for second order PDEs for example in [17], [18]. A crucial point in the construction of the p.g. vector field is that it is not merely a p.g. vector field for  $J$  but in fact a common p.g. vector field for  $J$  and restricted functionals,  $J_i$ , corresponding to  $J$  restricted to the members of  $\mathcal{U}(\xi, \mathcal{L})$ .

**Step 5** : An indirect argument is now employed. Assuming that  $\mathcal{B}$  contains no critical points of  $J$ , and using the flow that decreases  $J$  obtained via Step 4, we show  $\mathcal{B}$  can be deformed in such a fashion that there is a curve connecting  $u_0(r, \bar{h})$  and  $u_1(r, \bar{h})$  in  $J^c \cap B_{r^*}(K)$  where  $u_0(r, \bar{h})$

and  $u_1(r, \bar{h})$  are as in (B) of Proposition 3.1. But by (ii) of (B) in Proposition 3.1, no such path can exist. This contradiction completes the proof.

With this outline behind us, we begin with Step 1. When alternative (i) of Theorem 3.2 fails, we claim that the following condition,  $(P_1)$ , holds.

$(P_1)$  For any  $r$  and  $\lambda(r)$  as in Proposition 3.1 and  $\tilde{h} \in (0, \lambda(r)/4)$ , there exists an  $h \in (0, \tilde{h})$ ,  $\lambda_- < 0$ ,  $\lambda_+ > 0$ ,  $\lambda_0 > 0$ , and a  $\tilde{\nu} > 0$  such that

(i)  $(\lambda_- - 4\lambda_0, \lambda_- + 4\lambda_0) \subset (-\frac{1}{4}h, 0)$ ,  $(\lambda_+ - 4\lambda_0, \lambda_+ + 4\lambda_0) \subset (\frac{3}{2}h, 2h)$ ,  
and

(ii) if  $u \in B_{10r}(K)$  and

$$J(u) - \bar{c} \in (\lambda_- - 4\lambda_0, \lambda_- + 4\lambda_0) \cup (\lambda_+ - 4\lambda_0, \lambda_+ + 4\lambda_0),$$

then  $\|J'(u)\| \geq 2\tilde{\nu}$ .

Condition  $(P_1)$  will aid us in obtaining some useful estimates later.

To verify  $(P_1)$ , suppose that alternative (i) of Theorem 3.2 does not hold. Then for  $\tilde{h} \in (0, \lambda(r)/4)$ , there is a  $\lambda_+ \in (0, \tilde{h})$  such that there are no critical points of  $J$  at which  $J = \bar{c} + \lambda_+$  in  $B_{r^*}(K)$ . Choose  $h$  so that  $\lambda_+ \in (\frac{3}{2}h, 2h)$ . Again since (i) does not hold, there is a  $\lambda_- \in (-h/4, 0)$  such that there are no critical points of  $J$  at which  $J = \bar{c} + \lambda_-$  in  $B_{r^*}(K)$ . Thus for small  $\lambda_0 > 0$ , (i) of  $(P_1)$  holds. To prove  $(P_1)(ii)$ , arguing indirectly, suppose there is a sequence  $(u_p)$  in  $B_{10r}(K)$  with  $J(u_p) \rightarrow \{\bar{c} + \lambda_-\} \cup \{\bar{c} + \lambda_+\}$  and  $J'(u_p) \rightarrow 0$  as  $p \rightarrow \infty$ . Since  $10r < r^*$ ,  $(u_p) \subset B_{10r}(K) \subset B_{r^*}(\mathcal{A}_j)$ . Due to  $(J_3)(i) - (ii)$ ,  $(u_p) \subset \mathcal{A}_j$  and by  $(J_3)(iii)$ , as  $p \rightarrow \infty$ ,  $u_p \rightarrow u \in \mathcal{A}_j$  with  $J'(u) = 0$  and  $J(u) = \bar{c} + \lambda_-$  or  $J(u) = \bar{c} + \lambda_+$ . But by the choice of  $\lambda_{\pm}$ , such a  $u$  cannot exist. Thus  $(P_1)(ii)$  follows.

Turning now to Theorem 3.2, to prove it requires showing that if alternative (i) of the Theorem fails, the parameter  $\tilde{\mathcal{L}} = \mathcal{L}(\delta) \gg 1$  can be chosen so that independently of the choice of  $k \in \mathbb{N}$  and  $\xi^1, \dots, \xi^k \in \mathbb{Z}^n$  (subject to the constraint that  $\min_{i \neq j} |\xi^j - \xi^i| > 3\tilde{\mathcal{L}}$ ), there is a solution,  $U \in E$ , of (PDE) satisfying (ii) – (1) and (ii) – (2) of the Theorem. To obtain a result of this kind, a variational framework must be introduced which is simultaneously independent of the value of  $k$  and of the particular set of points  $\xi^j$ ,  $1 \leq j \leq k$  satisfying the constraint. Towards this end, the next step in our proof is the construction of a suitable finite partition,  $\mathcal{U}(\xi, \mathcal{L})$ , of  $\mathbb{R}^n$ . After some further preliminaries, this partition will be defined and its main properties stated.

Let  $\mathcal{L} \in \mathbb{N}$  be free for now and set

$$(3.6) \quad \bar{\mathcal{L}} = 10\sqrt{n}\mathcal{L}.$$

For  $p \in \mathbb{Z}^n$ , consider the family of  $n$ -cubes,  $Q_p \equiv Q_p(\mathcal{L})$ , given by

$$(3.7) \quad Q_p = 6p\mathcal{L} + [1/2 - 3\mathcal{L}, 1/2 + 3\mathcal{L}]^n.$$

Thus  $Q_p$  is an  $n$ -cube of side length  $6\mathcal{L}$  centered at  $(6p\mathcal{L} + "1/2")$  where "1/2" is an  $n$ -vector all of whose components equal  $1/2$ .

Note that

$$\text{int}(Q_p) \cap \text{int}(Q_q) = \emptyset \text{ if } p \neq q \in \mathbb{Z}^n \text{ and } \mathbb{R}^n = \cup_{p \in \mathbb{Z}^n} Q_p.$$

Let  $k \in \mathbb{N}$  with  $k \geq 2$  and choose  $\xi^1, \dots, \xi^k \in \mathbb{Z}^n$  such that

$$(3.8) \quad \min_{i \neq j} |\xi^j - \xi^i| > 3\bar{\mathcal{L}}.$$

For each  $j \in \{1, \dots, k\}$ , there is a unique  $p(\xi^j) = (p_1(\xi^j), \dots, p_n(\xi^j)) \in \mathbb{Z}^n$  such that

$$\xi^j \in Q_{p(\xi^j)}.$$

For  $\iota \in \{1, \dots, n\}$ , let

$$(3.9) \quad p_{\iota, \min}(\xi) = \min_{1 \leq j \leq k} p_{\iota}(\xi^j) \text{ and } p_{\iota, \max}(\xi) = \max_{1 \leq j \leq k} p_{\iota}(\xi^j).$$

Define

$$\mathcal{R}_{\xi} = [p_{1, \min}(\xi) - 1, p_{1, \max}(\xi) + 1] \times \dots \times [p_{n, \min}(\xi) - 1, p_{n, \max}(\xi) + 1]$$

so  $\xi^1, \dots, \xi^k \in \text{int}(\mathcal{R}_{\xi})$ . Thus  $\mathcal{R}_{\xi}$  is the smallest  $n$ -rectangle containing  $\{p(\xi^j) \mid j = 1, \dots, k\}$  in its interior.

Now the existence of the finite partition,  $\mathcal{U}(\xi, \mathcal{L})$ , of  $\mathbb{R}^n$  mentioned above can be established. Let  $\#S$  denotes the number of elements in the set,  $S$ . Consider the norm on  $\mathbb{R}^n$  given by

$$\|x\| = \max_{1 \leq i \leq n} |x_i|.$$

The closed ball of radius  $t$  about  $x$  will be denoted by  $\hat{B}_t(x)$ . For  $p, q \in \mathbb{Z}^n$ ,  $\|p - q\|$  provides a metric on  $\mathbb{Z}^n$ . The unit sphere about each such  $p$  contains  $3^n - 1$  points other than  $p$ . They will be referred to as the nearest neighbors to  $p$ . The next result provides the existence of  $\mathcal{U}(\xi, \mathcal{L})$  and states those of its properties that will be required later.

**Proposition 3.10.** *There exists a family of sets,*

$$\mathcal{U}(\xi, \mathcal{L}) \equiv \{\mathcal{U}_q \mid q \in \mathbb{Z}^n \cap \mathcal{R}_\xi\} \subset \mathbb{R}^n$$

*having the following properties:*

- i)  $\mathbb{R}^n = \cup_{q \in \mathbb{Z}^n \cap \mathcal{R}_\xi} \mathcal{U}_q$ .*
- ii)  $\text{int}(\mathcal{U}_q) \cap \text{int}(\mathcal{U}_s) = \emptyset$  for  $q \neq s \in \mathbb{Z}^n \cap \mathcal{R}_\xi$ .*
- iii)  $\xi^j + [-\mathcal{L}, \mathcal{L}]^n \subset \mathcal{U}_{p(\xi^j)}$  for each  $j \in \{1, \dots, k\}$ .*
- iv) Let  $q, s \in \mathbb{Z}^n \cap \mathcal{R}_\xi$ .*
  - ( $\alpha$ ) If  $q \neq s \in \mathcal{P} \equiv \{p(\xi^1), \dots, p(\xi^k)\}$ , then  $\hat{B}_\mathcal{L}(\mathcal{U}_q) \cap \mathcal{U}_s = \emptyset$ .*
  - ( $\beta$ ) If  $\hat{B}_\mathcal{L}(\mathcal{U}_q)$  and  $\mathcal{U}_s$  overlap, i.e.  $\hat{B}_\mathcal{L}(\mathcal{U}_q) \cap \mathcal{U}_s \neq \emptyset$ , then  $\|q - s\| \leq 1$ .*
  - ( $\gamma$ ) For any  $V \in \mathcal{U}(\xi, \mathcal{L})$ ,*

$$\begin{aligned} \#\{U \in \mathcal{U}(\xi, \mathcal{L}) \mid B_\mathcal{L}(V) \cap U \neq \emptyset\} &\leq \\ &\leq \#\{U \in \mathcal{U}(\xi, \mathcal{L}) \mid \hat{B}_\mathcal{L}(V) \cap U \neq \emptyset\} \leq 3^n. \end{aligned}$$

Before giving the proof of Proposition 3.10, some remarks about it are in order. The construction of  $\mathcal{U}(\xi, \mathcal{L})$  consists of two parts. First  $\mathbb{R}^n$  will be expressed as a finite union of collections of the  $n$ -rectangles,  $Q_q$ , and this partition satisfies properties *i) – ii)* of the Proposition. Then the sets in the finite union will be modified in such a way that the new family of sets satisfies *i) – iv)*. The starting point for the first part of the construction is the set  $\mathcal{R}_\xi$  or more precisely  $S_0 = \{Q_q \mid q \in \text{int}(\mathcal{R}_\xi) \cap \mathbb{Z}^n\}$ . The members of  $S_0$  form the core of the covering. The remainder of the sets in the covering are obtained by taking unions of further sets,  $Q_q$ . E.g. if  $n = 2$  and  $q$  is internal to an edge of the rectangular region,  $\mathcal{R}_\xi$ , the corresponding member of the covering family is a semi-infinite strip, while if  $q$  is a vertex of  $\mathcal{R}_\xi$ , the member of the covering family is a quarter plane as can be seen in Figure 1 below. Although it hasn't been explicitly mentioned in the statement of Proposition 3.10, but since it will be used later, we note at this point that the sets  $\mathcal{U}_q$ , being the union of adjacent squares with sides length 1, satisfy the uniform cone condition with respect to the cone,  $\mathcal{T}$ , introduced in Remark 2.7 of Section 2.

**Proof of Proposition 3.10:** Consider  $\mathbb{Z}^n \cap \mathcal{R}_\xi$ . Let  $S_0 = \{Q_q \mid q \in \text{int}(\mathcal{R}_\xi) \cap \mathbb{Z}^n\}$ . Choose any face of  $\mathcal{R}_\xi$ , say  $F_i = \mathcal{R}_\xi \cap \{x_i = p_{i,\min}(\xi) - 1 \text{ or } x_i = p_{i,\max}(\xi) + 1\}$  for some  $i, 1 \leq i \leq n$ . and let  $G_i$  denote  $\mathbb{Z}^n \cap F_i$ . Let  $q$  be an interior point of  $G_i$  (with respect to  $x_1 = p_{i,\min}(\xi) - 1$  or  $x_i = p_{i,\max}(\xi) + 1$ ) and consider  $Q_q$ . Moving  $Q_q$  to infinity in the direction of the unit outer normal to  $\mathcal{R}_\xi$  at  $F_i$  at  $q$ , sweeps out a semi-infinite  $n$ -rectangular region,  $Q_q^{ext}$ . Let  $S_1$  denote the totality of such regions obtained by considering all  $2n$  faces of  $\mathcal{R}_\xi$ . Next let  $s$  be a boundary point of  $G_i$ . There are  $n - 1$  different types of such boundary points, the type depending on the number of faces of  $\mathcal{R}_\xi$  that intersect at that point. That number,  $t$ , can be any of the integers  $2, \dots, n$ . Choose  $s$  so that  $t = 2$  and consider the pair of  $n$ -rectangular regions swept out by moving  $Q_s$  to infinity in the directions of the outer normals to each of the two faces. Take the convex hull of these two regions, obtaining a new rectangular region,  $Q_s^{ext}$ . E.g. if  $n = 2$ , we generate a quarter plane in this fashion. Let  $S_2$  denote the totality of the rectangular regions,  $W_\sigma$ , obtained in this fashion. Continuing this process by taking  $t = 3, \dots, t = n$ , we generate  $S_3, \dots, S_n$ . For  $q \in \mathbb{Z}^n \cap \mathcal{R}_\xi$ , denote the members of the set  $\cup_0^n S_i$  by  $\mathcal{V}_q$ . Thus  $\{\mathcal{V}_q \mid q \in \mathbb{Z}^n \cap \mathcal{R}_\xi\}$  is a partition of  $\mathbb{R}^n$  satisfying properties *i) - ii)* of Proposition 3.10.

Now the partition,  $\{\mathcal{V}_q \mid q \in \mathbb{Z}^n \cap \mathcal{R}_\xi\}$ , will be modified so as to satisfy properties *i) - iv)*. By definition  $p(\xi^j) \in \text{int}\mathcal{R}_\xi$  so  $\xi^j \in Q_{p(\xi^j)} = \mathcal{V}_{p(\xi^j)}$  for any  $j \in \{1, \dots, k\}$ , but we do not know where  $\xi^j$  is located in the set,  $\mathcal{V}_{p(\xi^j)}$  and in particular where it lies with respect to the boundary of  $\mathcal{V}_{p(\xi^j)}$ . Hence it may not be the case that  $\Xi_j \equiv \xi^j + [-\mathcal{L}, \mathcal{L}]^n \subset \mathcal{V}_{p(\xi^j)}$ . The simplest way to define a partition satisfying *i) - iii)* is to take

$$\mathcal{U}_{p(\xi^j)} = Q_{p(\xi^j)} \cup \Xi_j \text{ for each } j \in \{1, \dots, k\}$$

while for the remaining points  $q \in \mathbb{Z}^n \cap \mathcal{R}_\xi$ , let  $\mathcal{U}_q$  be the closure of

$$\begin{cases} Q_q \setminus \cup_{j=1}^k \Xi_j & \text{if } q \in \mathbb{Z}^n \cap \text{int}(\mathcal{R}_\xi) \setminus \mathcal{P}, \\ Q_q^{ext} \setminus \cup_{j=1}^k \Xi_j & \text{if } q \in \mathbb{Z}^n \cap \partial\mathcal{R}_\xi. \end{cases}$$

where  $Q_q^{ext}$  is the member of  $\cup_1^n S_i$  corresponding to  $q$ . The modified sets,  $\mathcal{U}(\xi, \mathcal{L})$  satisfy *i) - iii)*. Note also that if  $q \in \mathcal{P}$ ,  $\mathcal{U}_q \subset \hat{B}_\mathcal{L}(Q_q)$ .

To prove *iv)*( $\alpha$ ), suppose that  $q = p(\xi^j)$  and  $s = p(\xi^i)$ . Then  $q \in \text{int}\mathcal{R}_\xi$ ,

$$\hat{B}_\mathcal{L}(\mathcal{U}_q) = \hat{B}_\mathcal{L}(Q_q \cup \Xi_j) \subset 6q\mathcal{L} + \left[\frac{1}{2} - 5\mathcal{L}, \frac{1}{2} + 5\mathcal{L}\right]^n$$

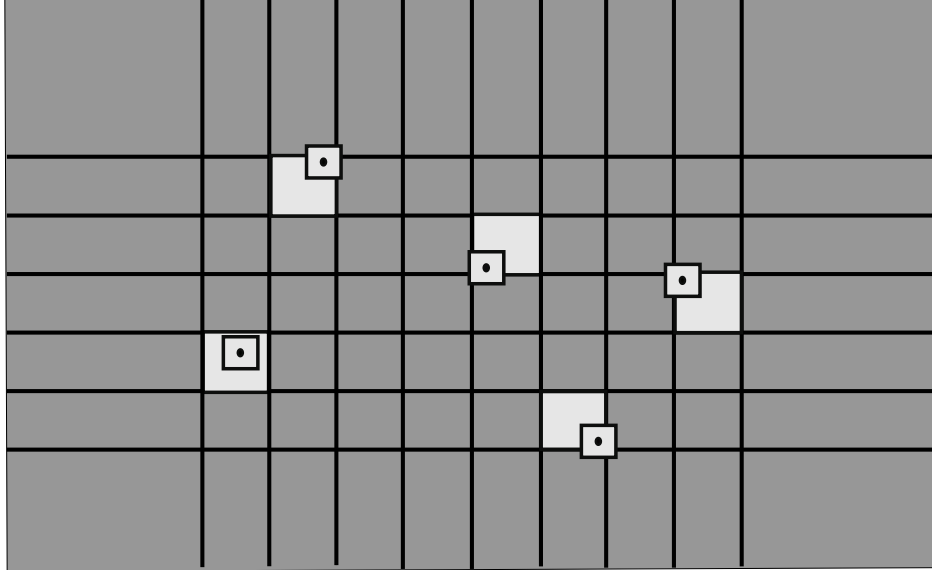

Figure 1: The dots represent the  $\xi^j$ , the white sets  $\mathcal{U}_{p(\xi^j)}$ , the gray ones the others  $\mathcal{U}$ 's

and  $\xi^j = 6q\mathcal{L} + \eta_j$  where  $\eta_j \in [\frac{1}{2} - 5\mathcal{L}, \frac{1}{2} + 5\mathcal{L}]^n$ . Similarly

$$\mathcal{U}_s = Q_s \cup \Xi_i \subset 6s\mathcal{L} + [\frac{1}{2} - 4\mathcal{L}, \frac{1}{2} + 4\mathcal{L}]^n$$

and  $\xi^i = 6s\mathcal{L} + \eta_i$  where  $\eta_i \in [\frac{1}{2} - 4\mathcal{L}, \frac{1}{2} + 4\mathcal{L}]^n$ . Therefore by (3.8)

$$(3.11) \quad 30\mathcal{L}\sqrt{n} = 3\bar{\mathcal{L}} < 6|q - s|\mathcal{L} + |\eta_j - \eta_i| \leq 6|q - s|\mathcal{L} + 9\mathcal{L}\sqrt{n}$$

so

$$\frac{7}{2}\sqrt{n} < |q - s| < \sqrt{n}\|q - s\|.$$

Consequently  $q$  and  $s$  are not nearest neighbors. Moreover if  $x \in \hat{B}_{\mathcal{L}}(\mathcal{U}_q)$  and  $y \in \mathcal{U}_s$ , similar estimates show

$$|x - y| \geq 6\mathcal{L}|q - s| - 9\mathcal{L}\sqrt{n} \geq 12\mathcal{L}\sqrt{n}$$

so  $\hat{B}_{\mathcal{L}}(\mathcal{U}_q) \cap \mathcal{U}_s = \emptyset$ .

The verification of  $iv)(\beta)$  involves a case analysis:

Case (a): Suppose that  $q \in \mathcal{P}$ , say  $q = p(\xi^j)$ . Then as above,  $q \in \text{int}\mathcal{R}_{\xi}$  and for any  $x \in \hat{B}_{\mathcal{L}}(\mathcal{U}_q)$ ,  $x = 6q\mathcal{L} + \zeta_q$  where  $\zeta_q \in [\frac{1}{2} - 5\mathcal{L}, \frac{1}{2} + 5\mathcal{L}]^n$ . From

$iv)(\alpha)$ ,  $s \notin \mathcal{P}$  and either (1)  $s \in \text{int}\mathcal{R}_\xi$  or (2)  $s \in \partial\mathcal{R}_\xi$ . If (1) occurs,

$$\mathcal{U}_s = Q_s \setminus \Xi_j \subset 6s\mathcal{L} + \left[\frac{1}{2} - 3\mathcal{L}, \frac{1}{2} + 3\mathcal{L}\right]^n.$$

Hence  $y \in \mathcal{U}_s$  implies  $y = 6s\mathcal{L} + \zeta_s$  where  $\zeta_s \in \left[\frac{1}{2} - 3\mathcal{L}, \frac{1}{2} + 3\mathcal{L}\right]^n$ . Since  $B_{\mathcal{L}}(\mathcal{U}_q) \cap \mathcal{U}_s \neq \emptyset$ , we can choose  $x = y$ . Therefore

$$(3.12) \quad 6(q - s)\mathcal{L} + \zeta_q - \zeta_s = 0.$$

But  $\|\zeta_q - \zeta_s\| \leq 8\mathcal{L}$ . Thus (3.12) can hold only if  $\|q - s\| \leq 1$ . Next suppose that (2) holds. Then  $\mathcal{U}_s \subset Q_s^{ext} \setminus \Xi_j$ . But since  $\hat{B}_{\mathcal{L}}(\mathcal{U}_q) \cap \mathcal{U}_s \neq \emptyset$ ,  $\hat{B}_{\mathcal{L}}(\mathcal{U}_q) \cap \mathcal{U}_s \subset Q_s \setminus \Xi_j \subset 6s\mathcal{L} + \left[\frac{1}{2} - 3\mathcal{L}, \frac{1}{2} + 3\mathcal{L}\right]^n$  so arguing as above, we conclude  $\|q - s\| \leq 1$ .

Case (b): Suppose that  $q \in \text{int}\mathcal{R}_\xi \setminus \mathcal{P}$ . Then either (1)  $s \in \text{int}\mathcal{R}_\xi$  or (2)  $s \in \partial\mathcal{R}_\xi$ . If (1) occurs,

$$\hat{B}_{\mathcal{L}}(\mathcal{U}_q) = \hat{B}_{\mathcal{L}}(Q_q \setminus \cup_1^k \Xi_i) \subset 6q\mathcal{L} + \left[\frac{1}{2} - 4\mathcal{L}, \frac{1}{2} + 4\mathcal{L}\right]^n$$

and arguing as above,

$$\hat{B}_{\mathcal{L}}(\mathcal{U}_q) \cap \mathcal{U}_s \subset \hat{B}_{\mathcal{L}}(Q_q \setminus \cup_1^k \Xi_i) \subset 6s\mathcal{L} + \left[\frac{1}{2} - 4\mathcal{L}, \frac{1}{2} + 4\mathcal{L}\right]^n$$

again leading to  $\|q - s\| \leq 1$ . If (2) holds, the last set of inclusions still hold as for Case (a)(2) and  $\|q - s\| \leq 1$ .

Case (c): Suppose  $q \in \partial\mathcal{R}_\xi$ . Then either (1)  $s \in \text{int}\mathcal{R}_\xi$  or (2)  $s \in \partial\mathcal{R}_\xi$ . For (1),  $\mathcal{U}_s \subset 6s\mathcal{L} + \left[\frac{1}{2} - 4\mathcal{L}, \frac{1}{2} + 4\mathcal{L}\right]^n$  and

$$\emptyset \neq \hat{B}_{\mathcal{L}}(\mathcal{U}_q) \cap \mathcal{U}_s \subset \hat{B}_{\mathcal{L}}(Q_q) = 6q\mathcal{L} + \left[\frac{1}{2} - 4\mathcal{L}, \frac{1}{2} + 4\mathcal{L}\right]^n$$

so as above,  $\|q - s\| \leq 1$ . If (2) occurs,  $\hat{B}_{\mathcal{L}}(\mathcal{U}_q) \cap \mathcal{U}_s$  may be unbounded. However due to the form of these two sets, they must intersect in  $\hat{B}_{\mathcal{L}}(Q_q) \cap Q_s$  which again yields  $\|q - s\| \leq 1$ .

To obtain  $iv)(\gamma)$ , suppose  $V = \mathcal{U}_q$  and  $U = \mathcal{U}_s$  where  $q, s \in \mathbb{Z}^n \cap \mathcal{R}_\xi$ . Then by  $iv)(\beta)$ ,  $\hat{B}_{\mathcal{L}}(\mathcal{U}_q) \cap \mathcal{U}_s \neq \emptyset$  implies  $\|q - s\| \leq 1$ . As was observed earlier, any  $q \in \mathbb{Z}^n \cap \mathcal{R}_\xi$  has at most  $3^n - 1$  nearest neighbors in  $\mathbb{Z}^n \cap \mathcal{R}_\xi$ . Therefore

$$\#\{U \in \mathcal{U}(\xi, \mathcal{L}) \mid \hat{B}_{\mathcal{L}}(V) \cap U \neq \emptyset\} \leq 3^n.$$

Since  $B_{\mathcal{L}}(V) \subset \hat{B}_{\mathcal{L}}(V)$  for any  $V \in \mathcal{U}(\xi, \mathcal{L})$ ,  $iv)(\gamma)$  follows and the proof of Proposition 3.10 is complete.

Using the partition  $\mathcal{U}(\xi, \mathcal{L})$ , the set in which we seek a multibump solution,  $U$ , of (PDE) can be introduced. It is convenient to suitably enumerate the elements of  $\mathbb{Z}^n \cap \mathcal{R}_{\xi}$ . Letting

$$M = \prod_{\iota=1}^n (p_{max,\iota} - p_{min,\iota} + 3)$$

denote the cardinality of  $\mathbb{Z}^n \cap \mathcal{R}_{\xi}$ , fix an enumeration by writing

$$\mathbb{Z}^n \cap \mathcal{R}_{\xi} = \{p^1, \dots, p^M\},$$

such that  $p^i = p(\xi^i)$  for  $i = 1, \dots, k$ . According to this definition,

$$(3.13) \quad \mathcal{U}(\xi, \mathcal{L}) = \{\mathcal{U}_i \equiv \mathcal{U}_{p^i} \mid 1 \leq i \leq M\}$$

where

$$\xi^i \in \mathcal{U}_i \text{ for } i = 1, \dots, k.$$

For  $\bar{r} > 0$ , consider the set

$$\mathcal{B}(\bar{r}, \xi, K) = \{u \in E \mid \max_{1 \leq j \leq k} \|u - f_{\xi^j}(K)\|_{\mathcal{U}_j} < \bar{r} \text{ and } \max_{k+1 \leq j \leq M} \|u\|_{\mathcal{U}_j} < \bar{r}\}.$$

The set  $\mathcal{B}(\bar{r}, \xi, K)$  also depends on the partition,  $\mathcal{U}(\xi, \mathcal{L})$ , but this dependence will be suppressed in our notation. The set  $\mathcal{B}(\bar{r}, \xi, K)$  consists of functions that are close to  $f_{\xi^j}(K)$  on  $\mathcal{U}_j$  for  $j = 1, \dots, k$  and close to 0 on  $\mathcal{U}_j$  for  $j = k+1, \dots, M$ . Our goal is to find critical points of the functional,  $J$ , in  $\mathcal{B}(\delta, \xi, K)$  when  $\mathcal{L}$  (and consequently  $\bar{\mathcal{L}}$  by (3.6)) is sufficiently large. By the nature of the set  $\mathcal{B}(\delta, \xi, K)$ , these critical points are then multibump solutions of (PDE). To obtain these critical points requires a closer look at the functional,  $J$ . Due to (i) of Proposition 3.10, for any  $u \in \mathcal{B}(\bar{r}, \xi, K)$ ,  $J(u)$  can be expressed as the sum of the restricted functionals

$$J_j(u) = \frac{1}{2} \|u\|_{\mathcal{U}_j}^2 - \int_{\mathcal{U}_j} F(x, u) dx, \quad j = 1, \dots, M.$$

We claim that  $J$  satisfies (PS) on  $\mathcal{B}(5r, \xi, K)$ . Proposition 2.10 shows this is the case provided that (2.11) holds for any (PS) sequence,  $(u_p) \subset \mathcal{B}(5r, \xi, K)$ , i.e.  $\|u_p\|_{T_q} < 2\bar{\rho}$  whenever  $q \in \mathbb{R}^n$  is large. But  $q$  large implies  $T_q$  is in the union of at most  $3^n$  different sets,  $\mathcal{U}_j$ , with  $k+1 \leq j \leq M$ . By the definition of

$\mathcal{B}(5r, \xi, K)$ ,  $\|u\|_{\mathcal{U}_j} < 5r$  for any  $j \geq k+1$  and by (3.4),  $3^n 5r < 2\bar{\rho}$ . Therefore  $\|u_p\|_{T_q} < 2\bar{\rho}$  for  $q$  large, verifying (PS). (See the proof of Proposition 4.57 below for more details).

Having established (PS) on  $\mathcal{B}(5r, \xi, K)$ , by using (2.5),  $(P_1)$  and property (A) of Proposition 3.1, a pseudogradient construction can be carried out leading to the following useful but rather technical result on the existence of a vector field that will play a crucial role in our main existence result. Its proof will be given in §4. The construction is similar to the one introduced in [32]; see also [17], [18].

**Proposition 3.14.** *Let  $r, r_1, r_2$  and  $r_3$  be as in (3.5) and for  $\tilde{h} \in (0, \frac{1}{4}\lambda(r))$ , let  $h \in (0, \tilde{h})$ ,  $\lambda_-, \lambda_+, \lambda_0$  be as in  $(P_1)$ . Then there is an  $\mathcal{L}_0 = \mathcal{L}_0(r, h) > 0$  such that for any  $k \in \mathbb{N}$  with  $k \geq 2$ , whenever the three conditions*

- (a)  $\mathcal{L} \geq 4\mathcal{L}_0$ ,
- (b)  $\xi^1, \dots, \xi^k \in \mathbb{Z}^n$  with  $\min_{1 \leq i \neq j \leq k} |\xi^i - \xi^j| > 30\sqrt{n}\mathcal{L}$ ,
- (c) there are no critical points of  $J$  in  $\mathcal{B}(5r, \xi, K)$ ,

are satisfied, then there exists a locally Lipschitz vector field  $\mathcal{V} : E \rightarrow E$ , possessing the following properties:

- (i)  $\max_{1 \leq j \leq M} \|\mathcal{V}(u)\|_{\mathcal{U}_j} \leq 1$  on  $E$  and  $J'(u)\mathcal{V}(u) \geq 0$  for all  $u \in E$ ;
- (ii)  $\mathcal{V}(u) = 0$  for  $u \in E \setminus \mathcal{B}(r_3, \xi, K)$ ;
- (iii) there is a constant,  $\mu_1 = \mu_1(r) > 0$  such that if  $u \in \mathcal{B}(r_2, \xi, K)$  and if for some  $j \in \{1, \dots, k\}$ ,

$$r_1 \leq \|u - f_{\xi^j}(K)\|_{\mathcal{U}_j} < r_2 \text{ and } |J_j(u) - \bar{c}| \leq \lambda(r),$$

or if for some  $j \in \{k+1, \dots, M\}$ ,

$$r_1 \leq \|u\|_{\mathcal{U}_j} < r_2,$$

then  $J'_j(u)\mathcal{V}(u) \geq \mu_1$ ;

- (iv) whenever  $u \in \mathcal{B}(r_3, \xi, K)$ , if for some  $j \in \{1, \dots, k\}$

$$J_j(u) - \bar{c} \in (\lambda_- - \lambda_0, \lambda_- + \lambda_0) \cup (\lambda_+ - \lambda_0, \lambda_+ + \lambda_0),$$

or if for some  $j \in \{k+1, \dots, M\}$

$$\lambda_+ - \lambda_0 < J_j(u) < \lambda_+ + \lambda_0,$$

then  $J'_j(u)\mathcal{V}(u) \geq 0$ ;

(v) if  $u \in \mathcal{B}(r_2, \xi, K)$ , there is a constant  $\mu_\xi > 0$  such that  $J'(u)\mathcal{V}(u) \geq \mu_\xi$ .

Note that the constant  $\mu_1$  given in (iii) of Proposition 3.14 depends only on  $r$  and not on  $\tilde{h}$ . In the following, Proposition 3.14 will be used by choosing  $\tilde{h} = \frac{1}{32} \min\{\lambda(r), \mu_1 r\}$ . Then (P1) is employed to determine the values of  $h, \lambda_-, \lambda_+, \lambda_0$  as in that condition. The value of  $h$  so determined will be denoted by  $\bar{h}$  and satisfies

$$(3.15) \quad \bar{h} \in (0, \frac{1}{32} \min\{\lambda(r), \mu_1 r\}).$$

The constant  $\bar{\mathcal{L}}$  of Theorem 3.2 will be determined next. For  $R > 0$ , define a cutoff function

$$\eta_R(x) = \min\{1, \max\{0, R - |x|\}\}$$

and with  $\gamma_{r,h}$  as in (B) of Proposition 3.1, set

$$\bar{\gamma}_{r,\bar{h},R}(\theta)(x) = \eta_R(x)\gamma_{r,\bar{h}}(\theta)(x) \text{ for } x \in \mathbb{R}^n \text{ and } \theta \in [0, 1].$$

Then, as  $R \rightarrow +\infty$ ,

$$(3.16) \quad \|\gamma_{r,\bar{h}}(\theta) - \bar{\gamma}_{r,\bar{h},R}(\theta)\| \rightarrow 0 \text{ and } |J(\gamma_{r,\bar{h}}(\theta)) - J(\bar{\gamma}_{r,\bar{h},R}(\theta))| \rightarrow 0$$

uniformly for  $\theta \in [0, 1]$ .

We claim  $\bar{R} = \bar{R}(r, \bar{h}) > 0$  can be chosen so large that  $\bar{\gamma}_{r,\bar{h},\bar{R}}$  satisfies

$$(\gamma_1) \quad \bar{\gamma}_{r,\bar{h},\bar{R}}(0), \bar{\gamma}_{r,\bar{h},\bar{R}}(1) \in J^{\bar{c}-\bar{h}/4} \setminus \bar{B}_{r_3}(K) \text{ and they do not lie on a path in } B_{r^*}(K) \cap J^{\bar{c}};$$

$$(\gamma_2) \quad \bar{\gamma}_{r,\bar{h},\bar{R}}([0, 1]) \subset \bar{B}_{4r+r/16}(K) \cap J^{\bar{c}+5\bar{h}/4};$$

$$(\gamma_3) \quad \text{if } \text{dist}_E(\bar{\gamma}_{r,\bar{h},\bar{R}}(\theta), K) \geq r_1, \text{ then } \bar{\gamma}_{r,\bar{h},\bar{R}}(\theta) \in J^{\bar{c}-\bar{h}/4};$$

$$(\gamma_4) \quad \text{supp}(\bar{\gamma}_{r,\bar{h},\bar{R}}(\theta)) \subset \overline{B_{\bar{R}}(0)} \text{ for any } \theta \in [0, 1].$$

Aside from the statement about  $\bar{B}_{r_3}(K)$  in  $(\gamma_1)$ , these properties are immediate from Proposition 3.1 and (3.16). Similarly to verify the  $\bar{B}_{r_3}(K)$  assertion, note that by (3.5),  $r_3 = 4r - r/8$ . By (B) of Proposition 3.1,  $u_0(r, \bar{h}) = \gamma_{r,\bar{h}}(0), u_1(r, \bar{h}) = \gamma_{r,\bar{h}}(1) \in \partial B_{4r}(K)$ . Hence the result follows from (3.16).

Due to the compactness of  $K$  in  $E$ , it can be further assumed that  $\bar{R}$  is so large that

$$(3.17) \quad \|u\|_{\mathbb{R}^N \setminus B_{\bar{R}}(0)} \leq r/16 \text{ for any } u \in K.$$

One further restriction on  $\bar{R}$  will be required later. Let  $[x]$  denote the greatest integer in  $x$  for  $x \in \mathbb{R}$ . Then the new restriction is:

$$(3.18) \quad [\bar{R}] > 96 \frac{\delta^2}{\min\{\frac{1}{4}|\lambda_- - \lambda_0|, \delta^2\}}.$$

Thus for future reference, observe that  $\bar{R}$  satisfies  $(\gamma_1) - (\gamma_4)$ , (3.17), and (3.18). Now finally let  $k \geq 2$  and set

$$(3.19) \quad \mathcal{L} = 5 \max\{1, [\bar{R}] + 1, [\mathcal{L}_0(r, \bar{h})] + 1\} \text{ and } \bar{\mathcal{L}} = 10\sqrt{n}\mathcal{L}.$$

Hence  $\bar{\mathcal{L}}$  depends on  $\bar{R}$  and the constant  $\mathcal{L}_0(r, \bar{h})$  given by Proposition 3.14.

An indirect variational argument will be used to obtain multibump solutions of (PDE). To begin to set up the variational framework for that argument, let  $\xi^1, \dots, \xi^k \in \mathbb{Z}^n$  satisfy

$$(3.20) \quad \min_{1 \leq i \neq j \leq k} |\xi^i - \xi^j| > 3\bar{\mathcal{L}}$$

and define the partition  $\mathcal{U}(\xi, \mathcal{L})$  as in (3.13). By  $(\gamma_4)$ , (3.19) and (3.20), the map  $G : [0, 1]^k \rightarrow E$ ,

$$(3.21) \quad G(\theta)(\cdot) = \sum_{j=1}^k \bar{\gamma}_{r, \bar{h}, \bar{R}}(\theta_j)(\cdot - \xi^j), \quad \theta = (\theta_1, \dots, \theta_k) \in [0, 1]^k,$$

is well defined and continuous.

**Proposition 3.22.** *G possesses the following properties:*

$$(G_0) \quad \text{supp}(G(\theta)) \subset \cup_{i=1}^k \mathcal{U}_j.$$

$$(G_1) \quad \text{If } \theta \in [0, 1]^k \text{ is such that } \theta_j = 0 \text{ or } \theta_j = 1, \text{ then } \|G(\theta) - f_{\xi^j}(K)\|_{\mathcal{U}_j} \geq r_3 \text{ and in particular } G(\theta) \in E \setminus \mathcal{B}(r_3, \xi, K).$$

$$(G_2) \quad G([0, 1]^k) \subset \mathcal{B}(5r, \xi, K).$$

$$(G_3) \quad G([0, 1]^k) \subset \cap_{j=1}^k \{J_j^{\bar{c}+3\bar{h}/2}\}.$$

$$(G_4) \quad \text{If for some } j \in \{1, \dots, k\}, \|G(\theta) - f_{\xi^j}(K)\|_{\mathcal{U}_j} \geq r_1, \text{ then } J_j(G(\theta)) \leq \bar{c} - \bar{h}/4.$$

$$(G_5) \quad \max_{\theta \in [0, 1]^k} J(G(\theta)) < k(\bar{c} + \lambda(r)).$$

**Proof:** Since  $\mathcal{L} > 5[\bar{R}] + 1$ , Property  $(G_0)$  follows from  $(\gamma_4)$  and the definition of  $\mathcal{U}(\xi, \mathcal{L})$ . For  $(G_1)$ , note that by (3.17),  $(\gamma_1)$  and  $(\gamma_4)$ ,

$$\begin{aligned} \|G(\theta) - f_{\xi_j}(K)\|_{\mathcal{U}_j} &= \|f_{\xi_j}(\bar{\gamma}_{r,\bar{h},\bar{R}}(\theta_j)) - f_{\xi_j}(K)\|_{\mathcal{U}_j} \geq \\ &\geq \|\bar{\gamma}_{r,\bar{h},\bar{R}}(\theta_j) - K\| - \sup_{u \in f_{\xi_j}(K)} \|u\|_{\mathbb{R}^n \setminus \mathcal{U}_j} > 4r - r/8 = r_3 \end{aligned}$$

for any  $j \in \{1, \dots, k\}$ . Next by  $(\gamma_2)$ ,

$$\|G(\theta) - f_{\xi_j}(K)\|_{\mathcal{U}_j} \leq \|\bar{\gamma}_{r,\bar{h},\bar{R}}(\theta_j) - K\| \leq 4r + r/16 < 5r$$

for any  $j \in \{1, \dots, k\}$  while by  $(G_0)$ ,  $\|G(\theta)\|_{\mathcal{U}_j} = 0$  for any  $j \in \{k+1, \dots, M\}$ . Hence  $(G_2)$  is proved. Property  $(G_3)$  follows since by  $(\gamma_2)$  and  $(\gamma_4)$ ,

$$J_j(G(\theta)) = J_j(f_{\xi_j}(\bar{\gamma}_{r,\bar{h},\bar{R}}(\theta_j))) = J(\bar{\gamma}_{r,\bar{h},\bar{R}}(\theta_j)) \leq \bar{c} + 5\bar{h}/4$$

for any  $\theta \in [0, 1]^k$  and  $j \in \{1, \dots, k\}$ . For  $(G_4)$ , note that

$$\|\bar{\gamma}_{r,\bar{h},\bar{R}}(\theta_j) - K\| \geq \|G(\theta) - f_{\xi_j}(K)\|_{\mathcal{U}_j} \geq r_1 = 3r + r/8.$$

Then by  $(\gamma_3)$  and  $(\gamma_4)$ ,

$$J_j(G(\theta)) = J(\bar{\gamma}_{r,\bar{h},\bar{R}}(\theta_j)) \leq \bar{c} - \bar{h}/4.$$

Lastly for  $(G_5)$ , by  $(\gamma_2)$  and  $(\gamma_4)$ ,

$$\max_{\theta \in [0, 1]^k} J(G(\theta)) \leq k \max_{\theta \in [0, 1]} J(\bar{\gamma}_{r,\bar{h},\bar{R}}(\theta)) \leq k(\bar{c} + 3\bar{h}/4).$$

To prove Theorem 3.2, it suffices to show that if (i) does not hold then  $\mathcal{B}(5r, \xi, K)$  contains critical points of  $J$ . Indeed if  $U \in \mathcal{B}(5r, \xi, K)$  is such that  $J'(U) = 0$ , then  $U$  is a classical solution of (PDE) such that, by (3.4),  $\max_{1 \leq j \leq k} \|u - f_{\xi_j}(K)\|_{\mathcal{U}_j} < 5r < \delta/(3^n \cdot 4)$  so part 1) of (ii) follows. To show that part 2) of (ii) also holds, note that by  $(iv)(\gamma)$  of Proposition 3.10, for any  $x \in \mathbb{R}^n$ ,  $B_{\bar{L}}(x)$  intersects at most  $3^n - 1$  of the sets  $V \in \mathcal{U}(\xi, \mathcal{L})$ , say  $\{V_1, \dots, V_{\bar{l}}\}$  with  $\bar{l} \leq 3^n - 1$ . For  $j \geq k + 1$ ,

$$\|U\|_{\mathcal{U}_j \cap B_{\bar{L}}(x)} \leq \|U\|_{\mathcal{U}_j} < 5r < \frac{\delta}{3^n \cdot 4}$$

and by (3.17), for  $1 \leq j \leq k$ ,

$$\|U\|_{\mathcal{U}_j \cap (B_{\bar{L}}(x) \setminus (\cup_{i=1}^k B_{\bar{L}}(\xi^i)))} \leq \|U - f_{\xi_j}(K)\|_{\mathcal{U}_j} + \max_{v \in f_{\xi_j}(K)} \|v\|_{\mathcal{U}_j \setminus B_{\bar{L}}(\xi^j)} < 6r < \frac{\delta}{3^n \cdot 3}.$$

Therefore

$$\|U\|_{B_{\bar{\mathcal{L}}}(x) \setminus (\cup_{j=1}^k B_{\bar{\mathcal{L}}}(\xi^j))} \leq \sum_{i=1}^{\bar{l}} \|U\|_{V_i \cup (B_{\bar{\mathcal{L}}}(x) \setminus (\cup_{j=1}^k B_{\bar{\mathcal{L}}}(\xi^j)))} \leq \sum_{i=1}^{\bar{l}} \delta / (3^n \cdot 3) < \delta$$

and (2) follows.

Now to prove that  $\mathcal{B}(5r, \xi, K)$  contains critical points of  $J$ , an indirect argument will be employed. Assume that (i) of Theorem 3.2 fails and that  $\mathcal{B}(5r, \xi, K)$  does not contain any critical points of  $J$ . With the further aid of (3.20) and  $\mathcal{L} \geq 5\mathcal{L}_0(r, h)$ , the hypotheses of Proposition 3.14 are satisfied so there exists a locally Lipschitz continuous vector field  $\mathcal{V} : E \rightarrow E$  satisfying properties (i)-(v) of that Proposition. Next the function,  $\mathcal{V}$ , will be employed to construct a deformation mapping that will play an important role in obtaining the desired contradiction. Thus consider the Cauchy problem:

$$(3.23) \quad \begin{cases} \frac{d}{ds} \eta(s, u) = -\mathcal{V}(\eta(s, u)) \\ \eta(0, u) = u. \end{cases}$$

There exists a continuous function  $\eta : \mathbb{R}^+ \times E \rightarrow E$ , satisfying (3.23).

**Proposition 3.24.** *The function,  $\eta$  possesses the following properties:*

- ( $\eta_0$ ) *The function  $s \rightarrow J(\eta(s, u))$  is not increasing on  $[0, +\infty)$  for any  $u \in E$ .*
- ( $\eta_1$ )  *$\eta(s, u) = u$  for any  $u \in E \setminus \mathcal{B}(r_3, \xi, K)$ , and  $s \geq 0$ .*
- ( $\eta_2$ ) *For  $s \geq 0$  and  $j \in \{1, \dots, k\}$ ,  $\eta(s, J_j^{\bar{c}+\lambda_--\lambda_0}) \subset J_j^{\bar{c}+\lambda_--\lambda_0}$ .*
- ( $\eta_3$ ) *For  $s \geq 0$ , if  $j \in \{1, \dots, k\}$ , then  $\eta(s, J_j^{\bar{c}+\lambda_+-\lambda_0}) \subset J_j^{\bar{c}+\lambda_+-\lambda_0}$  while if  $j \in \{k+1, \dots, M\}$ , then  $\eta(s, J_j^{\lambda_+-\lambda_0}) \subset J_j^{\lambda_+-\lambda_0}$ .*
- ( $\eta_4$ ) *There exists a  $T > 0$  such that whenever  $u \in \mathcal{B}(r_2, \xi, K)$  with  $J(u) \leq k(\bar{c} + \lambda(r))$ , there is a  $\tau_u \in (0, T)$  for which  $\eta(\tau_u, u) \notin \mathcal{B}(r_2, \xi, K)$ .*
- ( $\eta_5$ ) *If  $u \in \mathcal{B}(r_1, \xi, K) \cap \left( \cap_{j=1}^k J_j^{\bar{c}+\bar{h}} \right) \cap \left( \cap_{j=k+1}^M J_j^{\lambda_+-\lambda_0} \right)$  and  $J(u) \leq k(\bar{c} + \lambda(r))$ , then with  $T$  as in ( $\eta_4$ ),*

$$\eta(T, u) \in \cup_{j=1}^k J_j^{\bar{c}+\lambda_--\lambda_0}.$$

**Proof:** Item  $(\eta_0)$  follows from (3.23) since  $J'(u)\mathcal{V}(u) \geq 0$  for all  $u \in E$ . That  $\mathcal{V}(u) = 0$  for  $u \in E \setminus \mathcal{B}(r_3, \xi, K)$  implies  $(\eta_1)$ . To prove item  $(\eta_2)$ , let  $u \in E$  be such that  $J_j(u) \leq \bar{c} + \lambda_- - \lambda_0$ . If  $u \in E \setminus \mathcal{B}(r_3, \xi, K)$ , then by  $(\eta_1)$ ,  $J_j(\eta(s, u)) = J_j(u)$  for any  $s \geq 0$ . If  $u \in \mathcal{B}(r_3, \xi, K)$  and  $J_j(u) \leq \bar{c} + \lambda_- - \lambda_0$ , we claim there is no  $s_0 > 0$  for which  $J_j(\eta(s_0, u)) > \bar{c} + \lambda_- - \lambda_0$ . Combining these two observations then gives  $(\eta_2)$ . To verify the claim, if such an  $s_0$  exists, by the continuity of  $J_j(\eta(\cdot, u))$ , there is an interval  $(s_1, s_2) \subset (0, s_0)$  such that  $J_j(\eta(s, u)) \in (\bar{c} + \lambda_- - \lambda_0, \bar{c} + \lambda_- + \lambda_0)$  for any  $s \in (s_1, s_2)$  and  $J_j(\eta(s_2, u)) - J_j(\eta(s_1, u)) > 0$ . By the uniqueness of the solution of the Cauchy problem and  $(\eta_1)$ ,  $\eta(s, u) \in \mathcal{B}(r_3, \xi, K)$  for any  $s \in (s_1, s_2)$ . Moreover since  $J_j(\eta(s, u)) \in (\bar{c} + \lambda_- - \lambda_0, \bar{c} + \lambda_- + \lambda_0)$  for any  $s \in (s_1, s_2)$ , by property (iv) of Proposition 3.14,  $J'_j(\eta(s, u))\mathcal{V}(\eta(s, u)) \geq 0$  for any  $s \in (s_1, s_2)$ . Hence  $\frac{d}{ds}J_j(\eta(s, u)) = -J'_j(\eta(s, u))\mathcal{V}(\eta(s, u)) \leq 0$  for any  $s \in (s_1, s_2)$  and so  $J_j(\eta(s_2, u)) - J_j(\eta(s_1, u)) = \int_{s_1}^{s_2} \frac{d}{ds}J_j(\eta(s, u)) ds \leq 0$ , a contradiction. This proves  $(\eta_2)$  and an analogous argument based again on property (iv) of Proposition 3.14 gives  $(\eta_3)$ .

To obtain  $(\eta_4)$ , observe that if  $v \in \mathcal{B}(r_2, \xi, K)$  and  $J(v) \leq k(\bar{c} + \lambda(r))$ , by (v) of Proposition 3.14,  $J'(v)\mathcal{V}(v) \geq \mu_\xi > 0$ . If  $(\eta_4)$  is false, for every  $T > 0$  there is  $u \in \mathcal{B}(r_2, \xi, K)$  with  $J(u) \leq k(\bar{c} + \lambda(r))$  such that  $\eta(s, u) \in \mathcal{B}(r_2, \xi, K)$  for any  $s \in [0, T]$ . Then  $J(\eta(s, u)) \leq J(u) \leq k(\bar{c} + \lambda(r))$  for every  $s \in [0, T]$  and

$$(3.25) \quad J(\eta(T, u)) - J(u) = - \int_0^T J'(\eta(s, u))\mathcal{V}(\eta(s, u)) ds \leq -T\mu_\xi.$$

Letting  $T \rightarrow \infty$ , (3.25) implies  $\inf_{\mathcal{B}(r_2, \xi, K)} J(v) = -\infty$ . To see this is not possible, since  $J(u) = \sum_{i=1}^M J_i(u)$ , it suffices to show that  $J_i(u)$  is bounded from below on  $\mathcal{B}(r_2, \xi, K)$  for each  $i$ , for  $1 \leq i \leq M$ . For such  $u$ , if  $k+1 \leq i \leq M$ , then  $\|u\|_{\mathcal{U}_i} < r_2 < \bar{\rho}$  via (3.4) - (3.5). Therefore by (2.9),  $J_i(u) \geq \frac{1}{4}\|u\|_{\mathcal{U}_i}^2 \geq 0$ . If  $1 \leq i \leq k$  and  $u \in \mathcal{B}(r_2, \xi, K)$ , then  $u = v_i(x - \xi^i) + w_i$ , where  $v_i \in K$  and  $\|w_i\|_{\mathcal{U}_i} < r_2$ , so

$$(3.26) \quad J_i(u) \geq - \int_{\mathcal{U}_i} F(x, v_i(x - \xi^i) + w_i) dx.$$

Since the functions,  $v_i(x - \xi^i), w_i$  lie respectively in a compact set and a bounded set in  $E$ , (3.26) and (2.1) imply  $J_i$  is bounded from below on  $\mathcal{B}(r_2, \xi, K)$  and  $(\eta_4)$  follows.

It remains to verify  $(\eta_5)$ . Recall that  $\bar{h} < \frac{1}{32}\lambda(r)$  and also that

$$(\lambda_- - \lambda_0, \lambda_- + \lambda_0) \subset (-\frac{1}{4}\bar{h}, 0) \text{ and } (\lambda_+ - \lambda_0, \lambda_+ + \lambda_0) \subset (\frac{3}{2}\bar{h}, 2\bar{h}).$$

Suppose there exists an  $s \in [0, T]$  and  $j \in \{1, \dots, k\}$  such that  $J_j(\eta(s, u)) \leq \bar{c} - \lambda(r)/16$ . Since  $\bar{c} - \lambda(r)/16 < \bar{c} - 2\bar{h} < \bar{c} + \lambda_- - \lambda_0$ ,  $(\eta_3)$  shows that  $J_j(\eta(T, u)) \leq \bar{c} + \lambda_- - \lambda_0$  and  $(\eta_5)$  follows. Hence to complete the proof of  $(\eta_5)$ , we can assume  $s$  is such that

$$(3.27) \quad J_j(\eta(s, u)) > \bar{c} - \frac{1}{16}\lambda(r) \text{ for every } s \in [0, T] \text{ and } j \in \{1, \dots, k\}.$$

Since  $J_j(u) \leq \bar{c} + \bar{h} < \bar{c} + \lambda_+ - \lambda_0$  for any  $j \in \{1, \dots, k\}$ ,  $(\eta_3)$  implies

$$(3.28) \quad \max_{s \in [0, T]} J_j(\eta(s, u)) \leq \bar{c} + \lambda_+ - \lambda_0 < \bar{c} + 2\bar{h} < \bar{c} + \frac{1}{16}\lambda(r).$$

Moreover, by  $(\eta_4)$ , there is  $\tau_u \in (0, T)$  such that  $\eta(\tau_u, u) \notin \mathcal{B}(r_2, \xi, K)$ . Taking the infimum among such possible values of  $\tau_u$  we can assume  $\eta(s, u) \in \mathcal{B}(r_2, \xi, K)$  for any  $s \in (0, \tau_u)$ . Since  $u \in \mathcal{B}(r_1, \xi, K)$ , by definition  $\|u - f_{\xi^j}(K)\|_{\mathcal{U}_j} < r_1$  for each  $j \in \{1, \dots, k\}$  and  $\|u\|_{\mathcal{U}_j} \leq r_1$  for any  $j \in \{k+1, \dots, M\}$ . Since  $\eta(\tau_u, u) \notin \mathcal{B}(r_2, \xi, K)$ , there exists a  $j_u \in \{1, \dots, M\}$  such that either

- (a)  $j_u \leq k$  and  $\|\eta(\tau_u, u) - f_{\xi^{j_u}}(K)\|_{\mathcal{U}_{j_u}} \geq r_2$ , or
- (b)  $j_u \geq k+1$  and  $\|\eta(\tau_u, u)\|_{\mathcal{U}_{j_u}} \geq r_2$ .

We claim case (b) is not possible. Indeed, if (b) occurs, there exists an interval,  $(s_1, s_2) \subset (0, \tau_u)$ , such that  $\eta((s_1, s_2), u) \subset \mathcal{B}(r_2, \xi, K)$ ,

$$(3.29) \quad r_1 < \|\eta(s, u)\|_{\mathcal{U}_{j_u}} < r_2 \text{ for any } s \in (s_1, s_2), \quad \|\eta(s_2, u)\|_{\mathcal{U}_{j_u}} = r_2,$$

and

$$(3.30) \quad \|\eta(s_1, u) - \eta(s_2, u)\|_{\mathcal{U}_{j_u}} = r_2 - r_1.$$

Then (3.29) and (iii) of Proposition 3.14 imply that for any  $s \in (s_1, s_2)$ ,  $J'_{j_u}(\eta(s, u))\mathcal{V}(\eta(s, u)) \geq \mu_1$ . Thus

$$(3.31) \quad \begin{aligned} J_{j_u}(\eta(s_2, u)) &= J_{j_u}(\eta(s_1, u)) - \int_{s_1}^{s_2} J'_{j_u}(\eta(s, u))\mathcal{V}(\eta(s, u)) ds \\ &\leq J_{j_u}(\eta(s_1, u)) - \mu_1(s_2 - s_1). \end{aligned}$$

Since  $\|\mathcal{V}(\eta(s, u))\|_{\mathcal{U}_{j_u}} \leq 1$  for any  $s \in (s_1, s_2)$ , by (3.23) and (3.30),

$$(3.32) \quad r_2 - r_1 \leq \int_{s_1}^{s_2} \|\mathcal{V}(\eta(s, u))\|_{\mathcal{U}_{j_u}} ds \leq s_2 - s_1.$$

By hypothesis,  $J_{j_u}(u) \leq \lambda_+ - \lambda_0$ , so  $(\eta_3)$  implies  $J_{j_u}(\eta(s_1, u)) \leq \lambda_+ - \lambda_0 \leq 2\bar{h}$ . Recalling that  $r_2 - r_1 = r/2$  and combining the last inequality with (3.31), (3.15), and (3.32) yields

$$(3.33) \quad J_{j_u}(\eta(s_2, u)) \leq 2\bar{h} - \mu_1(s_2 - s_1) \leq \mu_1 r/16 - \mu_1 r/8 < 0.$$

On the other hand, by (3.29) and (3.4),  $\|\eta(s_2, u)\|_{\mathcal{U}_{j_u}} = r_2 < \bar{\rho}$ . Hence by (2.9),  $J_{j_u}(\eta(s_2, u)) \geq \frac{1}{4}\|\eta(s_2, u)\|_{\mathcal{U}_{j_u}}^2 \geq 0$ , contrary to (3.33). This contradiction shows that the case (b) cannot occur so that we have

$$(a) \quad j_u \in \{1, \dots, k\} \text{ and } \|\eta(\tau_u, u) - f_{\xi^{j_u}}(K)\|_{\mathcal{U}_{j_u}} \geq r_2.$$

To conclude the proof of  $(\eta_5)$ , repeating the argument that case (b) is impossible, by continuity there exists an interval,  $(s_1, s_2) \subset (0, \tau_u)$ , such that  $\eta((s_1, s_2), u) \subset \mathcal{B}(r_2, \xi, K)$ ,

$$(3.34) \quad r_1 < \|\eta(s, u) - f_{\xi^{j_u}}(K)\|_{\mathcal{U}_{j_u}} < r_2,$$

and

$$(3.35) \quad \|\eta(s_1, u) - \eta(s_2, u)\|_{\mathcal{U}_{j_u}} = r_2 - r_1.$$

Equations (3.27), (3.28), (3.34) and (iii) of Proposition 3.14, then imply that for any  $s \in (s_1, s_2)$ ,  $J'_{j_u}(\eta(s, u))\mathcal{V}(\eta(s, u)) \geq \mu_1$ . Thus as in (3.31),

$$(3.36) \quad J_{j_u}(\eta(s_2, u)) \leq J_{j_u}(\eta(s_1, u)) - \mu_1(s_2 - s_1).$$

and using (3.35) as in (3.32),

$$(3.37) \quad r_2 - r_1 \leq \int_{s_1}^{s_2} \|\mathcal{V}(\eta(s, u))\|_{\mathcal{U}_{j_u}} ds \leq s_2 - s_1.$$

As in the line following (3.32),  $J_{j_u}(\eta(s_1, u)) \leq \bar{c} + 2\bar{h}$ . Hence  $r_2 - r_1 = r/8$ ,  $\bar{h} < \mu_1 r/32$ , (3.36) and (3.37) imply

$$J_{j_u}(\eta(s_2, u)) \leq \bar{c} + 2\bar{h} - \mu_1 r/8 \leq \bar{c} + 2\bar{h} - 4\bar{h} = \bar{c} - 2\bar{h}.$$

As was shown at the beginning of the proof of  $(\eta_5)$ ,  $-2\bar{h} < \lambda_- - \lambda_0$ , so  $\eta(s_2, u) \in J_{j_u}^{\bar{c} + \lambda_- - \lambda_0}$ . Therefore by  $(\eta_2)$ ,  $\eta(T, u) = \eta(T - s_2, \eta(s_2, u)) \in J_{j_u}^{\bar{c} + \lambda_- - \lambda_0}$  and the proof of  $(\eta_5)$  is complete.

For  $G$  as given by (3.21) and  $\eta$  and  $T$  from Proposition 3.24, consider the map

$$\bar{G}(\theta) = \eta(T, G(\theta)).$$

We claim that

(3.38) for each  $\theta \in [0, 1]^k$ , there exists a  $j_\theta \in \{1, \dots, k\}$  such that

$$J_{j_\theta}(\bar{G}(\theta)) \leq \bar{c} + \lambda_- - \lambda_0.$$

Indeed if  $G(\theta) \notin \mathcal{B}(r_1, \xi, K)$ , since  $-\bar{h}/4 < \lambda_- - \lambda_0$ ,  $(G_4)$  holds and (3.38) is immediate from  $(\eta_2)$ . If  $G(\theta) \in \mathcal{B}(r_1, \xi, K)$ , then  $(G_3)$  implies the hypotheses of  $(\eta_5)$  are satisfied and (3.38) also follows for this case.

For  $j \in \{1, \dots, k\}$ , set

$$0_j = \{\theta \in [0, 1]^k \mid \theta_j = 0\} \text{ and } 1_j = \{\theta \in [0, 1]^k \mid \theta_j = 1\}.$$

Note that by  $(G_1)$ , and  $(\eta_1)$ ,

(3.39) if  $1 \leq j \leq k$  and  $\theta \in 0_j \cup 1_j$ , then  $\bar{G}(\theta) = G(\theta)$  and

$$J_j(\bar{G}(\theta)) < \bar{c} + \lambda_- - \lambda_0.$$

These observations yield:

**Proposition 3.40.** *There exists an  $\ell \in \{1, \dots, k\}$  and  $\gamma \in C([0, 1], [0, 1]^k)$  such that*

$$\gamma(0) \in 0_\ell, \gamma(1) \in 1_\ell \text{ and } \max_{\theta \in [0, 1]} J_\ell(\bar{G}(\gamma(\theta))) < \bar{c} + \frac{1}{2}(\lambda_- - \lambda_0).$$

**Proof:** If the result is false, for each  $j \in \{1, \dots, k\}$ ,

$$A_j = \{\theta \in [0, 1]^k \mid J_j(\bar{G}(\theta)) \geq \bar{c} + \frac{1}{2}(\lambda_- - \lambda_0)\}$$

separates  $0_j$  from  $1_j$  in  $[0, 1]^k$ . Equivalently if  $\mathcal{C} \subset [0, 1]^k$  is connected and such that  $\mathcal{C} \cap 0_j \neq \emptyset$  and  $\mathcal{C} \cap 1_j \neq \emptyset$ , then  $\mathcal{C} \cap A_j \neq \emptyset$ . The compactness of

$A_j$  implies there exists a  $\zeta > 0$  such that  $J_j(\bar{G}(\theta)) > \bar{c} + (\lambda_- - \lambda_0)$ , for any  $\theta \in N_\zeta(A_j) = \{\theta \in [0, 1]^k \mid |\theta - A_j| \leq \zeta\}$ . By (3.39)

$$J_j(\bar{G}(\theta)) < \bar{c} + (\lambda_- - \lambda_0) \text{ for } \theta \in 0_j \cup 1_j,$$

so  $N_\zeta(A_j) \cap (0_j \cup 1_j) = \emptyset$ . Let  $\mathcal{C}_j$  denote the component of  $[0, 1]^k \setminus N_\zeta(A_j)$  to which  $1_j$  belongs and for each  $j \in \{1, \dots, k\}$ , define the continuous function  $\sigma_j : [0, 1]^k \rightarrow \mathbb{R}$  by

$$\sigma_j(\theta) = \begin{cases} |\theta - N_\zeta(A_j)| & \text{if } \theta \in [0, 1]^k \setminus \mathcal{C}_j \\ -|\theta - N_\zeta(A_j)| & \text{if } \theta \in \mathcal{C}_j. \end{cases}$$

Then

$$\sigma_j|_{0_j} > 0, \sigma_j|_{1_j} < 0 \text{ and } \sigma_j(\theta) = 0 \text{ if and only if } \theta \in N_\zeta(A_j).$$

Hence for each  $j \in \{1, \dots, k\}$ , the function  $\sigma_j$  changes sign along any path joining  $0_j$  to  $1_j$ . Since  $\sigma = (\sigma_1, \dots, \sigma_k) : [0, 1]^k \rightarrow \mathbb{R}^k$  is continuous, by a theorem of C. Miranda, (see [16]), there exists a  $\theta^* \in [0, 1]^k$  such that  $\sigma_j(\theta^*) = 0$  for each  $j \in \{1, \dots, k\}$ . This implies in particular that  $\theta^* \in \bigcap_{1 \leq j \leq k} N_\zeta(A_j)$ , in contradiction with (3.38). Then there is an  $\ell \in \{1, \dots, k\}$  and a connected set  $\mathcal{C} \subset [0, 1]^k$  such that  $\mathcal{C} \cap 0_\ell \neq \emptyset$ ,  $\mathcal{C} \cap 1_\ell \neq \emptyset$  and  $\mathcal{C} \subset \{\theta \in [0, 1]^k \mid J_j(\bar{G}(\theta)) < \bar{c} + \frac{1}{2}(\lambda_- - \lambda_0)\}$ . Since  $\{\theta \in [0, 1]^k \mid J_j(\bar{G}(\theta)) < \bar{c} + \frac{1}{2}(\lambda_- - \lambda_0)\}$  is open in  $[0, 1]^k$ , there is actually a curve joining  $0_\ell$  and  $1_\ell$ , and the Proposition follows.

**Remark 3.41.** The proof of Proposition 3.40 is related to that of Proposition 3.4 in [10] and of Proposition 3.4 in [12].

Continuing with the proof of Theorem 3.2, observe that by  $(G_2)$  and  $(\eta_1)$ ,

$$(3.42) \quad \bar{G}([0, 1]^k) \subset \mathcal{B}(5r, \xi, K).$$

In particular by (3.42) and (3.17), since  $r < \delta/20$ , the triangle inequality shows that

$$(3.43) \quad \|\bar{G}(\theta)\|_{\mathcal{U}_j \setminus B_{\bar{R}}(\xi^j)} < \delta$$

for any  $j \in \{1, \dots, k\}$  and  $\theta \in [0, 1]^k$ .

Consider the path

$$g : s \in [0, 1] \rightarrow g(s) = \bar{G}(\gamma(s))|_{\mathcal{U}_\ell} \in W^{1,2}(\mathcal{U}_\ell, \mathbb{R}^m)$$

where  $\gamma$  is as determined in Proposition 3.40. It possesses the following properties:

$$(g_1) \quad g(0) = f_{\xi^{j_\ell}}(\bar{\gamma}_{r,\bar{h},\bar{R}}(0)) \text{ and } g(1) = f_{\xi^{j_\ell}}(\bar{\gamma}_{r,\bar{h},\bar{R}}(1)),$$

$$(g_2) \quad \max_{s \in [0,1]} J_{j_\ell}(g(s)) \leq \bar{c} + \frac{1}{2}(\lambda_- - \lambda_0),$$

$$(g_3) \quad \max_{s \in [0,1]} \|g(s)\|_{\mathcal{U}_{j_\ell} \setminus B_{\bar{R}}(\xi^{j_\ell})} < \delta.$$

Indeed,  $(g_2)$  follows from Proposition 3.40 and  $(g_3)$  from (3.43). To verify  $(g_1)$ , observe first that by Proposition 3.40,  $\gamma(0) \in 0_l$  and by (3.39),  $\bar{G}(\theta) = G(\theta)$  when  $\theta \in 0_l$ . Next (3.21) and  $(\gamma_4)$  imply  $g(0) = f_{\xi^{j_\ell}}(\bar{\gamma}_{r,\bar{h},\bar{R}}(0))$ . A similar argument yields the second statement in  $(g_1)$ .

The curve,  $g$ , does not possess enough properties for us to obtain the contradiction we seek. Therefore it will be modified to obtain a new curve  $g^* \in C([0, 1], W^{1,2}(\mathbb{R}^n, \mathbb{R}^m))$  with the support of  $g^*(s) \subset \overline{\mathcal{U}_{j_\ell}}$  for each  $s \in [0, 1]$  and satisfying

$$(g_1^*) \quad g^*(0) = f_{\xi^{j_\ell}}(\bar{\gamma}_{r,\bar{h},\bar{R}}(0)) \text{ and } g^*(1) = f_{\xi^{j_\ell}}(\bar{\gamma}_{r,\bar{h},\bar{R}}(1)),$$

$$(g_2^*) \quad J(g^*(s)) < \bar{c} + \frac{1}{4}(\lambda_- - \lambda_0),$$

$$(g_3^*) \quad \|g^*(s) - f_{\xi^{j_\ell}}(K)\| < r^*,$$

Assuming the existence of  $g^*$  and making a phase shift of  $-\xi^{j_\ell}$  then yields a new curve connecting  $u_0(r, \bar{h})$  and  $u_1(r, \bar{h})$  in  $J^{\bar{c}} \cap B_{r^*}(K)$ . But according to (ii) of (B) in Proposition 3.1, such a path cannot exist. Thus we have a contradiction to our assumption that there are no critical points of  $J$  in  $\mathcal{B}(5r, \xi, K)$  and Theorem 3.2 is proved.

Now we will begin the modification process and verify the existence of  $g^*$ . To simplify the notation, for  $X \subset \mathbb{R}^n$ , set  $J_X = J|_X$ . The notation  $J_i$  has already been used to denote  $J_{\mathcal{U}_i}$  but there should be no confusion between the two notations in what follows. Set  $S = \mathcal{U}_{j_\ell} \setminus B_{\bar{R}}(\xi^{j_\ell})$ . For any  $s \in [0, 1]$ , let

$$\Lambda(s) = \{v \in W^{1,2}(\mathcal{U}_{j_\ell}) \mid v|_{\overline{B_{\bar{R}}(\xi^{j_\ell})}} = g(s)|_{\overline{B_{\bar{R}}(\xi^{j_\ell})}} \text{ and } \|v\|_S \leq 3\delta\}.$$

That  $\Lambda(s)$  is nonempty follows since  $g(s) \in \Lambda(s)$  via  $(g_3)$  above. Consider the minimization problem

$$(3.44) \quad \inf_{v \in \Lambda(s)} J_S(v).$$

**Proposition 3.45.** *1<sup>o</sup> There exists a minimizer,  $U_s$ , of  $J_S$  in  $\Lambda(s)$ .*

2°  $\|U_s\|_S \leq 2\delta$ .

3°  $U_s$  is the unique minimizer of  $J_S$  in  $\Lambda(s)$ .

4°  $U_s$  satisfies

$$(3.46) \quad \|U_s\|_{B_{2\bar{R}+1}(\xi^{j_\ell}) \setminus B_{2\bar{R}}(\xi^{j_\ell})}^2 \leq 6 \min_{1 \leq i \leq [\bar{R}]} \|U_s\|_{B_{\bar{R}+i}(\xi^{j_\ell}) \setminus B_{\bar{R}+i-1}(\xi^{j_\ell})}^2.$$

5° For each  $s \in [0, 1]$ ,

$$(3.47) \quad \|U_s\|_{B_{2\bar{R}+1}(\xi^{j_\ell}) \setminus B_{2\bar{R}}(\xi^{j_\ell})}^2 \leq \frac{1}{4} \min\{\frac{1}{4}|\lambda_- - \lambda_0|, \delta^2\}.$$

**Proof:** The set  $\Lambda(s)$  is closed and convex. Therefore it is weakly closed. The functional  $J_S$  is weakly lower semicontinuous. Therefore there exists a minimizer,  $U_s$ , of  $J_S$  in  $\Lambda(s)$ . To prove 2°, suppose  $v \in \Lambda(s)$ . By the definition of  $\Lambda(s)$ ,  $\|v\|_S \leq 3\delta$ . By the argument leading to (2.5), for  $v \in \Lambda(s)$ ,

$$(3.48) \quad \begin{aligned} \int_S F(x, v) dx &\leq \frac{1}{8} \|v\|_S^2 + \frac{C_{1/4}}{p+1} \|v\|_{L^{p+1}(S)}^{p+1} \leq \left(\frac{1}{8} + \frac{C_{1/4}}{p+1} \kappa^{p+1} \|v\|_S^{p-1}\right) \|v\|_S^2 \\ &\leq \left(\frac{1}{8} + \frac{C_{1/4}}{p+1} \kappa^{p+1} (3\delta)^{p-1}\right) \|v\|_S^2. \end{aligned}$$

Recalling that  $\bar{\rho} \in (0, \rho/2)$  satisfies  $C_{1/4} \kappa^{p+1} (2\bar{\rho})^{p-1} \leq \frac{1}{4}$  and from (3.4) that  $\delta < \bar{\rho}/120$  shows for all  $v \in \Lambda(s)$ ,

$$(3.49) \quad \int_S F(x, v) dx \leq \frac{1}{4} \|v\|_S^2.$$

Thus with the aid of (g<sub>3</sub>),

$$(3.50) \quad \frac{1}{4} \|U_s\|_S^2 \leq J_S(U_s) \leq J_S(g(s)) \leq \frac{1}{2} \|g(s)\|_S^2 \leq \frac{1}{2} \delta^2$$

from which 2° follows. Note that 2° implies that  $U_s$  is an interior minimizer of  $J_S$ . Therefore

$$(3.51) \quad J'_S(U_s)\varphi = 0 \text{ for all } \varphi \in W_0^{1,2}(S).$$

If  $U_s$  is not the unique minimizer of  $J_S$  in  $\Lambda(s)$ , there is a second such minimizer,  $V_s$ , satisfying (3.49). Hence  $U_s - V_s \in W_0^{1,2}(S)$  so using it in (3.51):

$$(3.52) \quad \|U_s - V_s\|_S^2 = \int_S (F_u(x, U_s) - F_u(x, V_s)) \cdot (U_s - V_s) dx$$

$$= \int_S \left( \int_0^1 (F_{uu}(x, tU_s + (1-t)V_s)(U_s - V_s) dt) \cdot (U_s - V_s) dx.$$

Using (2.4) and arguing as in (3.48) leads to

$$(3.53) \quad \|U_s - V_s\|_S^2 \leq \left(\frac{1}{4} + pC_{1/4}\kappa^{p+1}(6\delta)^{p-1}\right) \|U_s - V_s\|_S^2.$$

Using (2.8) and that  $\delta < \bar{\rho}/120$ , the first factor on the right in (3.53) is less than 1. Hence  $U_s = V_s$  and  $3^o$  holds.

To prove  $4^o$ , let  $q_0 \in \{1, \dots, [\bar{R}]\}$  be such that

$$\|U_s\|_{B_{\bar{R}+q_0}(\xi^{j_\ell}) \setminus B_{\bar{R}+q_0-1}(\xi^{j_\ell})}^2 = \min_{1 \leq i \leq \bar{R}} \|U_s\|_{B_{\bar{R}+i}(\xi^{j_\ell}) \setminus B_{\bar{R}+i-1}(\xi^{j_\ell})}^2.$$

Define a cut-off function,  $\eta_{q_0}$ , by

$$\eta_{q_0}(x) = \begin{cases} 1 & x \in B_{\bar{R}+q_0-1}(\xi^{j_\ell}), \\ \bar{R} + q_0 - |x - \xi^{j_\ell}| & x \in B_{\bar{R}+q_0}(\xi^{j_\ell}) \setminus B_{\bar{R}+q_0-1}(\xi^{j_\ell}), \\ 0 & x \in \mathbb{R}^n \setminus B_{\bar{R}+q_0}(\xi^{j_\ell}). \end{cases}$$

Since  $U_s$  satisfies  $1^o$ ,

$$(3.54) \quad \begin{aligned} 0 &\leq J_{\mathcal{U}_{j_\ell} \setminus B_{\bar{R}}(\xi^{j_\ell})}(\eta_{q_0} U_s) - J_{\mathcal{U}_{j_\ell} \setminus B_{\bar{R}}(\xi^{j_\ell})}(U_s) = \\ &= J_{B_{\bar{R}+q_0}(\xi^{j_\ell}) \setminus B_{\bar{R}+q_0-1}(\xi^{j_\ell})}(\eta_{q_0} U_s) - J_{\mathcal{U}_{j_\ell} \setminus B_{\bar{R}+q_0-1}(\xi^{j_\ell})}(U_s). \end{aligned}$$

By (3.50),

$$(3.55) \quad J_{\mathcal{U}_{j_\ell} \setminus B_{\bar{R}+q_0-1}(\xi^{j_\ell})}(U_s) \geq \frac{1}{4} \|U_s\|_{B_{2\bar{R}+1}(\xi^{j_\ell}) \setminus B_{2\bar{R}}(\xi^{j_\ell})}^2.$$

Since  $\|\eta_{p_0} U_s\|_{B_{\bar{R}+q_0}(\xi^{j_\ell}) \setminus B_{\bar{R}+q_0-1}(\xi^{j_\ell})}^2 \leq 3 \|U_s\|_{B_{\bar{R}+q_0}(\xi^{j_\ell}) \setminus B_{\bar{R}+q_0-1}(\xi^{j_\ell})}^2$ , we find

$$(3.56) \quad \begin{aligned} J_{B_{\bar{R}+q_0}(\xi^{j_\ell}) \setminus B_{\bar{R}+q_0-1}(\xi^{j_\ell})}(\eta_{p_0} U_s) &\leq \frac{1}{2} \|\eta_{p_0} U_s\|_{B_{\bar{R}+q_0}(\xi^{j_\ell}) \setminus B_{\bar{R}+q_0-1}(\xi^{j_\ell})}^2 \\ &\leq \frac{3}{2} \|U_s\|_{B_{\bar{R}+q_0}(\xi^{j_\ell}) \setminus B_{\bar{R}+q_0-1}(\xi^{j_\ell})}^2. \end{aligned}$$

Hence (3.46) follows from (3.54), (3.55), (3.56).

Lastly  $5^o$ , will be verified. By  $2^o$ ,  $\|U_s\|_{\mathcal{U}_{j_\ell} \setminus B_{\bar{R}}(\xi^{j_\ell})} \leq 2\delta$  so

$$(3.57) \quad \sum_{i=1}^{[\bar{R}]} \|U_s\|_{B_{\bar{R}+i}(\xi^{j_\ell}) \setminus B_{\bar{R}+i-1}(\xi^{j_\ell})}^2 \leq 4\delta^2.$$

Using (3.18), (3.57) leads to

$$(3.58) \quad \min_{1 \leq i \leq \bar{R}} \|U_s\|_{B_{\bar{R}+i}(\xi^{j_\ell}) \setminus B_{\bar{R}+i-1}(\xi^{j_\ell})}^2 \leq \frac{1}{24} \min\{\frac{1}{4}|\lambda_- - \lambda_0|, \delta^2\}$$

for any  $s \in [0, 1]$ . Thus (3.47) and therefore 5<sup>o</sup> follow from (3.46) and (3.58).

Continuing with the construction of  $g^*$ , an intermediate step is needed to get from  $g$  to  $g^*$ . For  $s \in [0, 1]$ , define

$$\tilde{g}(s)(x) = \begin{cases} g(s)(x) & \text{for } x \in B_{\bar{R}}(\xi^{j_\ell}) \\ U_s(x) & \text{for } x \in S = \mathcal{U}_{j_\ell} \setminus B_{\bar{R}}(\xi^{j_\ell}) \end{cases}$$

The uniqueness of  $U_s$  for each  $s$  and the continuity of  $g$  shows that  $\tilde{g} \in C([0, 1], W^{1,2}(\mathcal{U}_{j_\ell}, \mathbb{R}^m))$ . See Section 5 of [11] for a related argument. Moreover the minimality property of  $U_s$  implies that for any  $s \in [0, 1]$

$$(3.59) \quad J_{j_\ell}(\tilde{g}(s)) = J_{B_{\bar{R}}(\xi^{j_\ell})}(g(s)) + J_S(U_s) \leq J_{j_\ell}(g(s)).$$

Consider the cutoff function

$$\eta(x) \equiv \eta_{R+1}(x) = \begin{cases} 1 & x \in B_{2\bar{R}}(\xi^{j_\ell}), \\ 2\bar{R} + 1 - |x - \xi^{j_\ell}| & x \in B_{2\bar{R}+1}(\xi^{j_\ell}) \setminus B_{2\bar{R}}(\xi^{j_\ell}), \\ 0 & x \in \mathbb{R}^n \setminus B_{2\bar{R}+1}(\xi^{j_\ell}) \end{cases}$$

and define the path,  $g^*$ , via

$$g^*(s)(x) = \begin{cases} \eta(x)\tilde{g}(s)(x) & \text{for } x \in \mathcal{U}_{j_\ell} \\ 0 & \text{for } x \in \mathbb{R}^n \setminus \mathcal{U}_{j_\ell}, \end{cases} \quad s \in [0, 1].$$

Then  $g^* \in C([0, 1], W^{1,2}(\mathbb{R}^n, \mathbb{R}^m))$  and its support lies in  $\bar{\mathcal{U}}_{j_\ell}$  for each  $s \in [0, 1]$ . We will prove that  $g^*$  satisfies  $(g_1^*) - (g_3^*)$ . Properties  $(g_1)$  and  $(\gamma_4)$  show  $\text{supp } g(0), \text{supp } g(1) \subset \bar{B}_{\bar{R}}(\xi^{j_\ell})$ . Thus  $g(0)|_{\partial B_{\bar{R}}(\xi^{j_\ell})} = g(1)|_{\partial B_{\bar{R}}(\xi^{j_\ell})} = 0$  so the definition of  $\Lambda(s)$  and (3.50) implies  $U_0 = U_1 = 0$ . Hence  $\tilde{g}(0) = g(0)$  and  $\tilde{g}(1) = g(1)$  on  $\mathcal{U}_{j_\ell}$  and  $g^*(0) = \eta g(0) = g(0)$  and  $g^*(1) = \eta g(1) = g(1)$  on  $\mathbb{R}^n$ . These observations then yield

$$(3.60) \quad g^*(0) = f_{\xi^{j_\ell}}(\bar{\gamma}_{r, \bar{h}, \bar{R}}(0)), \quad g^*(1) = f_{\xi^{j_\ell}}(\bar{\gamma}_{r, \bar{h}, \bar{R}}(1)),$$

i.e.  $(g_1^*)$ . To verify  $(g_2^*)$ , note first that

$$(3.61) \quad J(g^*(s)) = J_{j_\ell}(\eta \tilde{g}(s)) = J_{B_{2\bar{R}}(\xi^{j_\ell})}(\tilde{g}(s)) + J_{B_{2\bar{R}+1}(\xi^{j_\ell}) \setminus B_{2\bar{R}}(\xi^{j_\ell})}(\eta U_s).$$

We claim

$$(3.62) \quad J_{B_{2\bar{R}}(\xi^{j_\ell})}(\tilde{g}(s)) \leq J_{j_\ell}(g(s)).$$

Assuming (3.62) for the moment, (3.61) becomes

$$(3.63) \quad J(g^*(s)) \leq J_{j_\ell}(g(s)) + \frac{1}{2}\|\eta U_s\|_{B_{2\bar{R}+1}(\xi^{j_\ell}) \setminus B_{2\bar{R}}(\xi^{j_\ell})}^2.$$

Recalling that

$$\|\eta U_s\|_{B_{2\bar{R}+1}(\xi^{j_\ell}) \setminus B_{2\bar{R}}(\xi^{j_\ell})}^2 \leq 3\|U_s\|_{B_{2\bar{R}+1}(\xi^{j_\ell}) \setminus B_{2\bar{R}}(\xi^{j_\ell})}^2$$

and using  $(g_2)$  and (3.47), (3.63) leads to

$$(3.64) \quad J(g^*(s)) \leq \bar{c} + \frac{1}{2}(\lambda_- - \lambda_0) + \frac{3}{16}|\lambda_- - \lambda_0| < \bar{c} + \frac{1}{4}(\lambda_- - \lambda_0),$$

i.e.  $(g_2^*)$ . To prove (3.62), note first that it is equivalent to showing that

$$J_{B_{2\bar{R}}(\xi^{j_\ell}) \setminus B_{\bar{R}}(\xi^{j_\ell})}(U_s) \leq J_S(g(s)).$$

By (3.59),  $J_S(U_s) \leq J_S(g(s))$ . Thus to complete the proof here, it suffices to show

$$(3.65) \quad J_{\mathcal{U}_{j_\ell} \setminus B_{2\bar{R}}(\xi^{j_\ell})}(U_s) \geq 0$$

and this follows from (2.9), (3.4), and  $2^o$  of Proposition 3.45.

Lastly to verify  $(g_3^*)$ ,  $\|g^*(s) - f_{\xi^{j_\ell}}(K)\|$  will be estimated. Since  $g^* = 0$  in  $\mathbb{R}^n \setminus B_{2\bar{R}+1}(\xi^{j_\ell})$ ,

$$(3.66) \quad \|g^*(s) - f_{\xi^{j_\ell}}(K)\| \leq \|g^*(s) - f_{\xi^{j_\ell}}(K)\|_{B_{2\bar{R}+1}(\xi^{j_\ell})} + \|f_{\xi^{j_\ell}}(K)\|_{\mathbb{R}^n \setminus B_{2\bar{R}+1}(\xi^{j_\ell})}.$$

The second term on the right in (3.66) is  $\leq r/16$  due to (3.17). Next note that

$$(3.67) \quad \|g^*(s) - f_{\xi^{j_\ell}}(K)\|_{B_{2\bar{R}+1}(\xi^{j_\ell})} \leq \|g^* - g\|_{B_{2\bar{R}+1}(\xi^{j_\ell})} + \|g - f_{\xi^{j_\ell}}(K)\|_{B_{2\bar{R}+1}(\xi^{j_\ell})}$$

and the second term on the right in (3.67) is  $\leq 5r$  by (3.42). To bound the first term on the right in (3.67), note that

$$\|U_s\|_{B_{2\bar{R}+1}(\xi^{j_\ell}) \setminus B_{\bar{R}}(\xi^{j_\ell})} \leq \|U_s\|_S < 2\delta$$

by  $2^\circ$  of Proposition 3.45, and

$$\|g(s)\|_{B_{2\bar{R}+1}(\xi^{j_\ell}) \setminus B_{\bar{R}}(\xi^{j_\ell})} \leq \|g(s)\|_{U_{j_\ell} \setminus B_{\bar{R}}(\xi^{j_\ell})} \leq \delta$$

by  $(g_3)$ . These inequalities with (3.4) show

$$\begin{aligned} \|g^*(s) - g(s)\|_{B_{2\bar{R}+1}(\xi^{j_\ell})} &= \|\eta U_s - g(s)\|_{B_{2\bar{R}+1}(\xi^{j_\ell}) \setminus B_{\bar{R}}(\xi^{j_\ell})} \\ &\leq \|\eta U_s\|_{B_{2\bar{R}+1}(\xi^{j_\ell}) \setminus B_{\bar{R}}(\xi^{j_\ell})} + \|g(s)\|_{B_{2\bar{R}+1}(\xi^{j_\ell}) \setminus B_{\bar{R}}(\xi^{j_\ell})} \\ &\leq \sqrt{3} 2\delta + \delta < r^*/2. \end{aligned}$$

Combining these observations and using (3.4) again yields

$$(3.68) \quad \|g^*(s) - f_{\xi^{j_\ell}}(K)\| \leq r^*/2 + 5r < r^*,$$

i.e.  $(g_3^*)$  holds. Thus there is a critical point of  $J$  in  $\mathcal{B}(5r, \xi, K)$ . By Proposition 2.21, the critical point is a classical solution of (PDE) and finally the proof of Theorem 3.2 is complete.

**Remark 3.69.** Using arguments as in [11], it follows that the k-bump solutions decay to 0 at an exponential rate as  $|x| \rightarrow \infty$ .

This section now concludes with the

**Proof of Corollary 3.3:** Let  $(\xi^i)$  be a sequence as in the statement of the Corollary. Let  $k \in \mathbb{N}$  and  $P_k = \{\xi^1, \dots, \xi^k\}$ . With this choice of vectors, by Theorem 3.2 and Corollary 2.21, there is a solution,  $U_k \in C_{loc}^{2,\alpha}(\mathbb{R}^n)$  of (PDE) satisfying (ii) 1) – 2) of Theorem 3.2. Let  $(y_i)_{i \in \mathbb{N}} \subset \mathbb{R}^n$  be such that  $\cup_{i \in \mathbb{N}} B_{\bar{\mathcal{L}}}(y_i) = \mathbb{R}^n$ . We claim there is a constant,  $M > 0$  independent of  $i$  and  $k$  such that

$$(3.70) \quad \|F_u(\cdot, U_k)\|_{B_{\bar{\mathcal{L}}+1}(y_i)} \leq M.$$

Assuming (3.70) for the moment, it implies that there is a subsequence of  $U_k$  and a function,  $U \in C_{loc}^2(\mathbb{R}^n)$  such that  $U_k \rightarrow U$  in  $C_{loc}^2(\mathbb{R}^n)$ . Therefore  $U$  is a solution of (PDE) in  $\mathbb{R}^n$  and the linear Schauder regularity theory [13] implies  $U \in C_{loc}^{2,\alpha}(\mathbb{R}^n)$  for each  $\alpha \in (0, 1)$ . In addition, by (ii) 1) – 2) for  $U_k$ ,  $U$  also satisfies these conditions with equality being possible. To verify (3.70), note first that due to the compactness of  $K$  in  $E$ ,  $\{\|f_{\xi^j}(K)\|_{B_{\bar{\mathcal{L}}+1}(y_i)}\}$  is bounded independently of  $i$  and  $j$ . Therefore via (ii) 1) – 2), the same is true of  $\{\|U_k\|_{B_{\bar{\mathcal{L}}+1}(y_i)}\}$  independently of  $i$  and  $k$ . As in the proof of Proposition 2.21, by (F1) – (F4), there is a  $p > 1$  such that  $\|F_u(\cdot, U_k)\|_{L^p(B_{\bar{\mathcal{L}}+1}(y_i))}$  is also

bounded independently of  $i$  and  $k$ . The linear  $L^p$  Schauder interior estimates then give a bound on  $\{\|U_k\|_{W^{2,p}(B_{\tilde{\mathcal{L}}}(y_i))}\}$  independently of  $i$  and  $k$ . Bootstrap arguments e.g. in the spirit of section 5 of [11] and using the linear Schauder  $C^\alpha$  theory for the final step show (3.70) is verified and complete the proof of Corollary 3.3.

## 4 Proof of Proposition 3.14

The goal of this section is to prove Proposition 3.14. The Proposition will be obtained as a consequence of the following result which provides a vector field with useful properties on  $\mathcal{B}(4r, \xi, K)$ .

**Proposition 4.1.** *Let  $r$  be as in (3.4),  $\tilde{h} \in (0, \frac{1}{4}\lambda(r))$ , with  $\lambda(r)$  as given by Proposition 3.1, and  $h \in (0, \tilde{h})$ ,  $\lambda_-, \lambda_+, \lambda_0$  given by (P1). Then there exist constants  $\mu_1 = \mu_1(r)$ ,  $\mu_2 = \mu_2(r, h)$  and  $\mathcal{L}_0 = \mathcal{L}_0(r, h) > 0$  such that if  $\mathcal{L} \geq 4\mathcal{L}_0$ ,  $k \geq 2$  and the points  $\xi^1, \dots, \xi^k \in \mathbb{Z}^n$  satisfy  $\min_{1 \leq i \neq j \leq k} |\xi^i - \xi^j| > 30\sqrt{n}\mathcal{L}$ , then with the partition  $\mathcal{U}(\xi, \mathcal{L})$  as given by (3.13), for any  $u \in \mathcal{B}(4r, \xi, K)$ , there exists a  $\mathcal{V}_u \in E$  possessing the properties:*

$$1^\circ \max_{j=1, \dots, M} \|\mathcal{V}_u\|_{\mathcal{U}_j} \leq 1,$$

2 $^\circ$  if for some  $j_0 \in \{1, \dots, k\}$ , the inequalities

$$3r < \|u - f_{\xi^{j_0}}(K)\|_{\mathcal{U}_{j_0}} < 4r \text{ and } |J_{j_0}(u) - \bar{c}| \leq \frac{3}{2}\lambda(r),$$

are satisfied, then  $J'_{j_0}(u)\mathcal{V}_u \geq 2\mu_1$ , while if for some  $j \in \{k+1, \dots, M\}$ ,

$$3r \leq \|u\|_{\mathcal{U}_j} < 4r,$$

then  $J'_j(u)\mathcal{V}_u \geq 2\mu_1$ ;

3 $^\circ$  if for some  $j_0 \in \{1, \dots, k\}$ , the inequalities

$$J_{j_0}(u) - \bar{c} \in (\lambda_- - 2\lambda_0, \lambda_- + 2\lambda_0) \cup (\lambda_+ - 2\lambda_0, \lambda_+ + 2\lambda_0)$$

are satisfied, then  $J'_{j_0}(u)\mathcal{V}_u \geq 2\mu_2$ , while if for some  $j \in \{k+1, \dots, M\}$ , we have

$$\lambda_+ - 2\lambda_0 < J_j(u) < \lambda_+ + 2\lambda_0,$$

then  $J'_j(u)\mathcal{V}(u) \geq 2\mu_2$ .

If in addition, the set  $\bar{\mathcal{B}}(4r, \xi, K)$  does not contain critical points of  $J$ , there exists a  $\mu_\xi > 0$  for which

$$4^\circ \quad J'(u)\mathcal{V}_u \geq 2\mu_\xi \text{ for any } u \in \mathcal{B}(4r, \xi, K).$$

Proposition 4.1 will be proved below. First it will be used to give a

**Proof of Proposition 3.14:** Recall that  $r_1 = 3r + r/8$ ,  $r_2 = 3r + r/4$ ,  $r_3 = 4r - r/8$ . Let  $u \in \bar{\mathcal{B}}(r_3, \xi, K)$ , and let the constants  $\mu_\xi, \mu_1, \mu_2, \lambda(r), \lambda_0$  be as in Proposition 4.1. The parameter  $\lambda_0$  is given by  $(P_1)$  which is operative (as is Proposition 3.14) when (i) of Theorem 3.2 fails. Choose a constant  $\rho_u > 0$  so that the following conditions are satisfied.

$$(\rho_1) \quad \rho_u < r/8;$$

$$(\rho_2) \quad \text{if } v \in B_{\rho_u}(u), \text{ then } |J_j(v) - J_j(u)| \leq \frac{1}{2} \min\{\lambda(r), \lambda_0\} \text{ for any } j \in \{1, \dots, M\};$$

$$(\rho_3) \quad \text{if } v \in B_{\rho_u}(u), \text{ then } |(J'(v) - J'(u))\mathcal{V}_u| \leq \mu_\xi \text{ and } |(J'_j(v) - J'_j(u))\mathcal{V}_u| \leq \min\{\mu_1, \mu_2\} \text{ for any } j \in \{1, \dots, M\}.$$

The family of open balls,  $\{B_{\rho_u}(u) \mid u \in \bar{\mathcal{B}}(r_3, \xi, K)\}$ , is a covering of  $\bar{\mathcal{B}}(r_3, \xi, K)$ . Hence, by paracompactness, it admits an open locally finite refinement,  $\{\mathcal{N}_i \subset E \mid i \in \mathbb{N}\}$ . To verify  $(1^\circ)$ , we argue as in e.g. Appendix A of [26]. For  $u \in E$ , define

$$\phi_i(u) = \text{dist}_E(u, E \setminus \mathcal{N}_i), \quad \Phi(u) = \sum_{i \in \mathbb{N}} \phi_i(u) \text{ and } \psi_i(u) = \frac{\phi_i(u)}{\Phi(u)}$$

Each function,  $\phi_i$ , is Lipschitz continuous with  $\text{supp } \phi_i \subset \bar{\mathcal{N}}_i$ . Since the covering  $\{\mathcal{N}_i\}$  is locally finite,  $\Phi$  is strictly positive and locally Lipschitz continuous on  $\bar{\mathcal{B}}(r_3, \xi, K)$ . Consequently the functions  $\psi_i$ ,  $i \in \mathbb{N}$ , are also locally Lipschitz continuous on  $\bar{\mathcal{B}}(r_3, \xi, K)$  and form a partition of unity on  $\bar{\mathcal{B}}(r_3, \xi, K)$  subordinate to the open covering  $\{\mathcal{N}_i\}$ .

Since  $\{\mathcal{N}_i\}$  is a refinement of  $\{B_{\rho_u}(u) \mid u \in \bar{\mathcal{B}}(r_3, \xi, K)\}$ , for any  $i \in \mathbb{N}$ , a function  $v_i \in \bar{\mathcal{B}}(r_3, \xi, K)$  can be selected such that  $\mathcal{N}_i \subset B_{\rho_{v_i}}(v_i)$ . Set

$$\chi(u) = \frac{\text{dist}_E(u, E \setminus \bar{\mathcal{B}}(r_3, \xi, K))}{\text{dist}_E(u, E \setminus \bar{\mathcal{B}}(r_3, \xi, K)) + \text{dist}_E(u, \bar{\mathcal{B}}(r_2, \xi, K))},$$

and define

$$(4.2) \quad \mathcal{V}(u) = \chi(u) \sum_{i \in \mathbb{N}} \psi_i(u) \mathcal{V}_{v_i}.$$

Observing that  $\chi$  is locally Lipschitz continuous on  $E$ ,  $\chi = 0$  on  $E \setminus \bar{\mathcal{B}}(r_3, \xi, K)$ , the functions  $\psi_j$  are locally Lipschitz continuous on  $\bar{\mathcal{B}}(r_3, \xi, K)$  and the sum in the definition of  $\mathcal{V}$  is locally a finite sum, it follows that  $\mathcal{V}$  is also locally Lipschitz continuous on  $E$ . By Proposition 4.1, the vectors  $\mathcal{V}_{v_i}$  satisfy  $\max_{1 \leq j \leq M} \|\mathcal{V}_{v_i}\|_{\mathcal{U}_j} \leq 1$  and  $J'(u)\mathcal{V}_{v_i} \geq 0$ . Thus  $\mathcal{V}(u)$ , being the product of the positive function  $\chi(u)$ , which has modulus less than or equal to one, and a convex combination of a finite number of vectors  $\mathcal{V}_{v_i}$ , also satisfies  $\|\mathcal{V}(u)\|_{\mathcal{U}_j} \leq 1$  for any  $j \in \{1, \dots, M\}$  and  $J'(u)\mathcal{V}(u) \geq 0$ . i.e  $\mathcal{V}$  satisfies (i) of Proposition 3.14. To prove (ii) of the Proposition, observe that  $\chi(u) = 0$  for  $u \in E \setminus \mathcal{B}(r_3, \xi, K)$ . Thus for such  $u$ ,  $\mathcal{V}(u) = 0$ .

The verification of (iii) of Proposition 3.14 is more involved. Let (p1) and (p2) denote the two possible cases considered in (iii) of Proposition 3.14, i.e.

(p1) for some  $j_0 \in \{1, \dots, k\}$ ,

$$r_1 \leq \|u - f_{\xi^{j_0}}(K)\|_{\mathcal{U}_{j_0}} < r_2 \text{ and } |J_{j_0}(u) - \bar{c}| \leq \lambda(r);$$

(p2) for some  $j_1 \in \{k+1, \dots, M\}$ ,  $r_1 \leq \|u\|_{\mathcal{U}_{j_1}} < r_2$ .

Since  $u \in \mathcal{B}(r_2, \xi, K)$ , observing that  $\mathcal{B}(r_2, \xi, K) \subset \cup_{i \in \mathbb{N}} \mathcal{N}_i$ , it follows that

(a) there is an  $i \in \mathbb{N}$  such that  $\psi_i(u) \neq 0$ .

Thus there is a  $v_i \in \bar{\mathcal{B}}(r_3, \xi, K)$  such that  $u \in \mathcal{N}_i \subset B_{\rho_{v_i}}(v_i)$ . Since  $r_3 < 4r$ ,  $v_i \in \mathcal{B}(4r, \xi, K)$ . Note further that if (p1) occurs,

$$\|v_i - f_{\xi^{j_0}}(K)\|_{\mathcal{U}_{j_0}} \geq \|u - f_{\xi^{j_0}}(K)\|_{\mathcal{U}_{j_0}} - \|u - v_i\|_{\mathcal{U}_{j_0}} \geq r_1 - \rho_{v_i} > 3r$$

and by  $(\rho_2)$ ,  $|J_{j_0}(v_i) - J_{j_0}(u)| \leq \frac{1}{2}\lambda(r)$  so

$$|J_{j_0}(v_i) - \bar{c}| \leq |J_{j_0}(u) - \bar{c}| + |J_{j_0}(v_i) - J_{j_0}(u)| \leq \frac{3}{2}\lambda(r).$$

Thus we have shown if (p1) holds,

$$(4.3) \quad v_i \in \mathcal{B}(4r, \xi, K), \quad 3r < \|v_i - f_{\xi^{j_0}}(K)\|_{\mathcal{U}_{j_0}} < 4r \text{ and } |J_{j_0}(v_i) - \bar{c}| \leq \frac{3}{2}\lambda(r).$$

Similarly if (p2) occurs, again using  $(\rho_1)$  gives

$$\|v_i\|_{\mathcal{U}_{j_1}} \geq \|u\|_{\mathcal{U}_{j_1}} - \|u - v_i\|_{\mathcal{U}_{j_1}} \geq r_1 - \rho_{v_i} > 3r$$

which combined with what was established above yields

$$(4.4) \quad v_i \in \mathcal{B}(4r, \xi, K) \text{ and } 3r < \|v_i\|_{\mathcal{U}_{j_1}} < 4r.$$

Using (4.3) and (4.4),  $2^\circ$  of Proposition 4.1 can be applied where  $\bar{j} = j_0$  if (p1) holds and  $\bar{j} = j_1$  if (p2) occurs. Thus with  $\mu_1$  as given by Proposition 4.1, we find  $J'_{\bar{j}}(v_i)\mathcal{V}_{v_i} \geq 2\mu_1$  and by  $(\rho_3)$ ,

$$J'_j(u)\mathcal{V}_{v_i} \geq J'_j(v_i)\mathcal{V}_{v_i} - |(J'_j(v_i) - J'_j(u))\mathcal{V}_{v_i}| \geq \mu_1.$$

Noting that  $\chi(u) = 1$  since  $u \in \mathcal{B}(r_2, \xi, K)$  gives

$$J'_j(u)\mathcal{V}(u) = \sum_{\{i|\psi_i(u) \neq 0\}} \psi_i(u)J'_j(u)\mathcal{V}_{v_i} \geq \sum_{\{i|\psi_i(u) \neq 0\}} \psi_i(u)\mu_1 = \mu_1,$$

and (iii) of Proposition 3.14 follows.

A similar argument proves (iv) of Proposition 3.14. Assume that  $u \in \mathcal{B}(r_3, \xi, K)$  is such that one of the following properties is satisfied:

(p3) for some  $j_0 \in \{1, \dots, k\}$ ,

$$J_{j_0}(u) - \bar{c} \in (\lambda_- - \lambda_0, \lambda_- + \lambda_0) \cup (\lambda_+ - \lambda_0, \lambda_+ + \lambda_0)$$

(p4) for some  $j_1 \in \{k+1, \dots, M\}$ ,

$$\lambda_+ - \lambda_0 < J_{j_1}(u) < \lambda_+ + \lambda_0.$$

As in the proof of (iii), (a) holds, so by  $(\rho_1)$ ,  $v_i \in \mathcal{B}(4r, \xi, K)$  and by  $(\rho_2)$ ,  $|J_j(v_i) - J_j(u)| \leq \frac{1}{2}\lambda_0$  for  $1 \leq j \leq M$ . If (p3) or (p4) hold, the hypotheses of  $3^\circ$  of Proposition 4.1 are satisfied so setting  $\bar{j} = j_0$  if (p3) occurs or  $\bar{j} = j_1$  if (p4) occurs, it follows that  $J'_{\bar{j}}(v_i)\mathcal{V}_{v_i} \geq 2\mu_2$ . Hence, by  $(\rho_3)$ ,

$$J'_j(u)\mathcal{V}_{v_i} \geq J'_{\bar{j}}(v_i)\mathcal{V}_{v_i} - |(J'_{\bar{j}}(v_i) - J'_j(u))\mathcal{V}_{v_i}| \geq \mu_2.$$

As earlier,  $\chi(u) = 1$  so we conclude

$$J'_j(u)\mathcal{V}(u) = \sum_{\{i|\psi_i(u) \neq 0\}} \psi_i(u)J'_j(u)\mathcal{V}_{v_i} \geq \mu_2 > 0,$$

establishing (iv) of Proposition 3.14.

To complete the proof of Proposition 3.14, it remains only to verify property (v). Let  $u \in \mathcal{B}(r_2, \xi, K)$ . Due to (a) and  $(\rho_1)$ ,  $v_i \in \mathcal{B}(4r, \xi, K)$ . By assumption, there are no critical points of  $J$  in  $\mathcal{B}(4r, \xi, K)$ . Consequently by 4<sup>o</sup> of Proposition 4.1,  $J'(v_i)\mathcal{V}_{v_i} \geq 2\mu_\xi$  so by  $(\rho_3)$ ,

$$J'(u)\mathcal{V}_{v_j} \geq \mu_\xi \text{ for any } j \in \mathbb{N} \text{ such that } \psi_j(u) \neq 0.$$

Again  $\chi(u) = 1$  so

$$J'(u)\mathcal{V}(u) = \sum_{\{j|\psi_j(u) \neq 0\}} \psi_j(u)J'(u)\mathcal{V}_{v_j} \geq \mu_\xi,$$

finishing the proof of Proposition 3.14.

The remainder of the paper consists of the proof of Proposition 4.1. Due to its length and technical nature, we preface the proof with some clarifying remarks and an outline of the main steps. The proof of the Proposition is based on the use of Property (A) of Proposition 3.1, which is the main tool used to verify 2<sup>o</sup> of Proposition 4.1, and the employment of property  $(P_1)$  to derive 3<sup>o</sup>. Property 4<sup>o</sup> of Proposition 4.1 is obtained as a consequence of Proposition 2.10 under the assumption that  $\mathcal{B}(4r, \xi, K)$  does not contain critical points of  $J$ .

To describe the underlying ideas a bit more fully, consider the first part of Property 2<sup>o</sup>. It states that if  $u \in \mathcal{B}(4r, \xi, K)$  satisfies

$$(4.5) \quad 3r < \|u - f_{\xi^{j_0}}(K)\|_{\mathcal{U}_{j_0}} < 4r \text{ and } |J_{j_0}(u) - \bar{c}| \leq \frac{3}{2}\lambda(r),$$

for some  $j_0 \in \{1, \dots, k\}$ , then  $J'_{j_0}(u)\mathcal{V}_u \geq 2\mu_1$ . The relationship between this statement and Property (A) of Proposition 3.1 is particularly explicit when the restriction of  $u$  to  $\mathcal{U}_{j_0}$ , the function  $v_{j_0} = u|_{\mathcal{U}_{j_0}}$ , is such that  $\text{supp}(v_{j_0}) \subset \text{int}(\mathcal{U}_{j_0})$ . Indeed, then extending  $v_{j_0}$  as 0 outside  $\mathcal{U}_{j_0}$ , shows that  $v_{j_0} \in E$  and by (4.5),  $v_{j_0}$  satisfies

$$(4.6) \quad |J(v_{j_0}) - \bar{c}| = |J_{j_0}(u) - \bar{c}| \leq \frac{3}{2}\lambda(r),$$

$$(4.7) \quad 3r < \|v_{j_0} - f_{\xi^{j_0}}(K)\| < 5r \text{ if } \mathcal{L} \text{ is suitably large.}$$

By (4.6) - (4.7), Property (A) of Proposition 3.1 can be applied to the function  $v_{j_0}$  yielding  $\|J'(v_{j_0})\| \geq 2\mu_r$ . Since  $J'(v_{j_0})h = J'_{j_0}(u)h$  for any  $h \in E$ , we find  $V_{j_0} \in E$  with  $\|V_{j_0}\| \leq 1$ ,  $\text{supp}V_{j_0} \subset \text{int}(\mathcal{U}_{j_0})$  and  $J'_{j_0}(u)V_{j_0} \geq \mu_r$ . Then

$V_{j_0}$  can be used to construct  $\mathcal{V}_u$ . In other words, when  $\text{supp}(u|_{\mathcal{U}_{j_0}}) \subset \text{int}(\mathcal{U}_{j_0})$ , Property (A) of Proposition 3.1 can be applied to the single bump function  $v_{j_0} = u|_{\mathcal{U}_{j_0}}$ . A similar mechanism exploiting Property ( $P_1$ ) should then lead to  $3^\circ$ . To use these ideas a suitable family of cutoff functions related to the partition  $\mathcal{U}_1, \dots, \mathcal{U}_M$  will be constructed. It will allow us to isolate the behavior of  $u$  on each domain  $\mathcal{U}_j$ .

An outline of the above process is:

**Step 1** : Various constants are fixed and the family of cutoff functions is defined. The construction has to take account of the errors due to the cutting procedure and requires several preliminaries and some estimates which are summarized in Proposition 4.19 below.

**Step 2** : In preparation for the proof of  $2^\circ$ , Property (A) of Proposition 3.1 is used in conjunction with the family of cutoff functions. See Proposition 4.37 below.

**Step 3** : Property ( $P_1$ ) is used in a similar fashion to obtain  $3^\circ$ . See Proposition 4.49.

**Step 4** : In preparation for  $4^\circ$  of Proposition 4.1, Proposition 2.10 is used exploiting the fact that  $\mathcal{B}(4r, \xi, K)$  does not contain critical points of  $J$ . See Proposition 4.57.

**Step 5** : The final part of the proof shows how to put together all the contributions derived from the preceding steps to define a vector field  $\mathcal{V}_u$  satisfying the properties stated in Proposition 4.1. See (4.63).

Now we are ready for the

**Proof of Proposition 4.1:** Define

$$(4.8) \quad \mu_1 = \mu_1(r) = \frac{1}{100} \min\{\mu_r^2, r^2, \lambda(r)\}, \quad \bar{\mu}_2 = \bar{\mu}_2(r, h) = \frac{1}{100} \min\{\nu^2, r^2, \lambda_0\}.$$

where  $\mu_r$  is given by (A) in Proposition 3.1,  $h$  is fixed via (3.15) and  $\nu$  by property (P1). Take

$$(4.9) \quad \epsilon_0 < \frac{1}{3^n} \frac{1}{32} \min\{r, \mu_1, \bar{\mu}_2, \lambda(r)^{1/2}, \lambda_0^{1/2}\}$$

Since  $K$  is compact in  $E$ , there exists an  $R_0 > 0$  such that

$$(4.10) \quad \|v\|_{\mathbb{R}^n \setminus B_{R_0}(0)} \leq \epsilon_0, \quad \text{for all } v \in K.$$

Let

$$(4.11) \quad \mathcal{L}_0 = \mathcal{L}_0(r, h) \in \mathbb{N} \text{ be such that } \mathcal{L}_0 \geq \max\{R_0, 3^n \cdot 50 r^2 / \epsilon_0\}$$

and  $\mathcal{L} \in \mathbb{N}$  such that  $\mathcal{L} \geq 4\mathcal{L}_0$ . Given  $k \geq 2$  and  $\xi^1, \dots, \xi^k \in \mathbb{Z}^n$  satisfying  $|\xi^i - \xi^j| > 30\sqrt{n}\mathcal{L}$  for  $i \neq j$ , consider the family  $\mathcal{U}(\xi, \mathcal{L}) = \{\mathcal{U}_1, \dots, \mathcal{U}_M\}$  defined as in (3.13). Recall that by (iii) of Proposition 3.10, we have  $\xi^j + [-\mathcal{L}, \mathcal{L}]^n \subset \mathcal{U}_j$  for  $1 \leq j \leq k$ . Then, since  $\mathcal{L} \geq 4\mathcal{L}_0$ , (i) and (ii) of Proposition 3.10 imply that for any  $j \in \{1, \dots, k\}$  and  $i \in \{1, \dots, M\}$ , we have

$$(4.12) \quad B_{4\mathcal{L}_0}(\xi^j) \subset \mathcal{U}_j \text{ and } B_{2\mathcal{L}_0}(\xi^j) \cap B_{\mathcal{L}_0}(\mathcal{U}_i) = \emptyset \text{ whenever } i \neq j.$$

Let  $u \in \mathcal{B}(4r, \xi, K)$  and  $j \in \{1, \dots, k\}$ . Since  $\mathcal{L} \geq 4\mathcal{L}_0$  and  $\mathcal{L}_0 \geq R_0$ , (4.10) and (4.12) show that

$$4r \geq \|u - f_{\xi^j}(K)\|_{\mathcal{U}_j \setminus B_{\mathcal{L}_0}(\xi^j)} \geq \|u\|_{\mathcal{U}_j \setminus B_{\mathcal{L}_0}(\xi^j)} - \epsilon_0.$$

Hence by (4.9),

$$(4.13) \quad \|u\|_{\mathcal{U}_j \setminus B_{\mathcal{L}_0}(\xi^j)} \leq 5r \text{ for any } j \in \{1, \dots, k\}.$$

Moreover, since for any  $j \in \{1, \dots, k\}$ ,

$$\{x \in \mathbb{R}^n \mid \mathcal{L}_0 \leq |x - \xi^j| \leq 2\mathcal{L}_0\} \subset \mathcal{U}_j \setminus B_{\mathcal{L}_0}(\xi^j),$$

(4.13) and (4.11) imply that

$$(4.14) \quad \min_{0 \leq l \leq \mathcal{L}_0 - 1} \|u\|_{\{\mathcal{L}_0 + l \leq |x - \xi^j| \leq \mathcal{L}_0 + l + 1\}}^2 \leq \frac{25r^2}{\mathcal{L}_0} \leq \frac{1}{2}\epsilon_0 \text{ for } 1 \leq j \leq k.$$

For each  $u \in \mathcal{B}(4r, \xi, K)$  and  $j \in \{1, \dots, k\}$ , the minimum in (4.14) is achieved at some integer  $l_{u,j} \in \{\mathcal{L}_0, \dots, 2\mathcal{L}_0 - 1\}$ . Although  $l_{u,j}$  is not necessarily determined uniquely, any such choice suffices for our later purposes. For  $j = 1, \dots, k$ , set

$$\mathcal{N}_{u,j}^{int} = B_{l_{u,j}+1}(\xi^j) \setminus B_{l_{u,j}}(\xi^j) \text{ and } A_u = \mathbb{R}^n \setminus \bigcup_{j=1}^k B_{l_{u,j}+1}(\xi^j).$$

See Figure 2 below. Then by (4.14),

$$(4.15) \quad \|u\|_{\mathcal{N}_{u,j}^{int}}^2 \leq \frac{1}{2}\epsilon_0 \text{ for any } j \in \{1, \dots, k\}.$$

The inequalities, (4.15), show that in each such annular region,  $\mathcal{N}_{u,j}^{int}$ , around  $\xi^j$ , the function  $u$  has a very small norm.

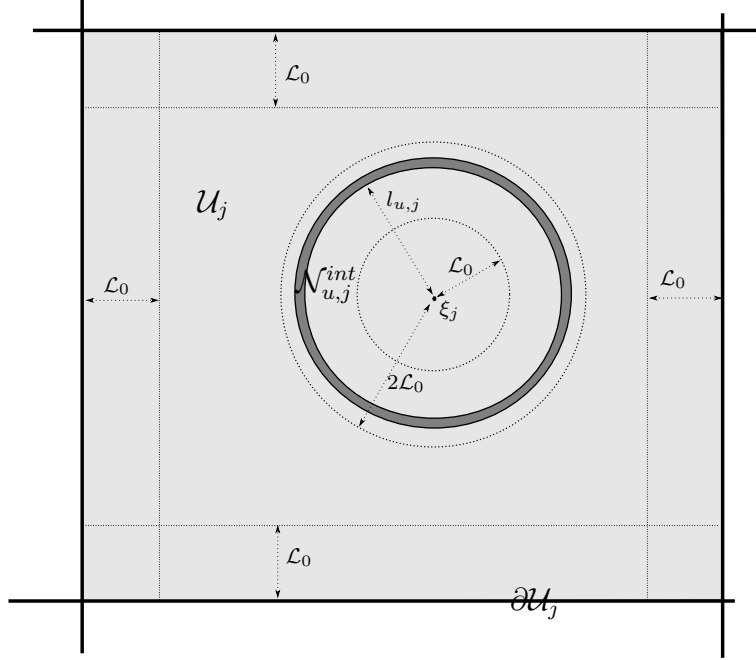

Figure 2:  $\mathcal{N}_{u,j}^{int}$ ,  $j \leq k$ , is represented in dark gray,  $\mathcal{U}_j$  in gray. By (4.12),  
 $\mathcal{N}_{u,j}^{int} \cap B_{\mathcal{L}_0}(\mathcal{U}_i) = \emptyset$  if  $i \neq j$ .

In an analogous fashion, annular regions surrounding each set  $\mathcal{U}_i \in \mathcal{U}(\xi, \mathcal{L})$ ,  $\mathcal{N}_{u,i}^{ext}$  can be constructed for which the same inequality holds. The first step in proving this is to show that

$$(4.16) \quad \|u\|_{B_{\mathcal{L}_0}(\mathcal{U}_i) \setminus \mathcal{U}_i}^2 \leq 3^n \cdot 25 r^2 \text{ for any } i \in \{1, \dots, M\}.$$

Indeed (i), (ii) and (iv) of Proposition 3.10 imply

$$\|u\|_{B_{\mathcal{L}_0}(\mathcal{U}_i) \setminus \mathcal{U}_i}^2 \leq 3^n \max\{\|u\|_{V \cap (B_{\mathcal{L}_0}(\mathcal{U}_i) \setminus \mathcal{U}_i)}^2 \mid V \in \mathcal{U}(\xi, \mathcal{L}), B_{\mathcal{L}}(\mathcal{U}_i) \cap V \neq \emptyset\}.$$

By the definition of  $\mathcal{B}(4r, \xi, K)$ ,  $\|u\|_V^2 \leq 16r^2$  for any  $V \in \{\mathcal{U}_{k+1}, \dots, \mathcal{U}_M\}$ . By (4.12) and (4.13),  $\|u\|_{V \cap (B_{\mathcal{L}_0}(\mathcal{U}_i) \setminus \mathcal{U}_i)}^2 \leq 25r^2$  for any  $V \in \{\mathcal{U}_1, \dots, \mathcal{U}_k\}$ . Combining these observations yields

$$(4.17) \quad \max\{\|u\|_{V \cap (B_{\mathcal{L}_0}(\mathcal{U}_i) \setminus \mathcal{U}_i)}^2 \mid V \in \mathcal{U}(\xi, \mathcal{L}), B_{\mathcal{L}}(\mathcal{U}_i) \cap V \neq \emptyset\} \leq 25r^2$$

and (4.16) follows. Since  $\mathcal{L}_0 \geq 3^n \cdot 50 r^2 / \epsilon_0$ , as for (4.14), we obtain

$$\min_{0 \leq l \leq \mathcal{L}_0 - 1} \|u\|_{B_{l+1}(\mathcal{U}_i) \setminus B_l(\mathcal{U}_i)}^2 \leq \frac{3^n \cdot 25 r^2}{\mathcal{L}_0} \leq \frac{1}{2} \epsilon_0 \text{ for } 1 \leq i \leq M.$$

Hence as above, for each  $u \in \mathcal{B}(4r, \xi, K)$  and  $i \in \{1, \dots, M\}$ , there exists an integer  $\bar{l}_{u,i} \in \{0, \dots, \mathcal{L}_0 - 1\}$ , such that for the set

$$\mathcal{N}_{u,i}^{ext} \equiv B_{\bar{l}_{u,i}+1}(\mathcal{U}_i) \setminus B_{\bar{l}_{u,i}}(\mathcal{U}_i),$$

(pictured in Figure 3) we have

$$(4.18) \quad \|u\|_{\mathcal{N}_{u,i}^{ext}}^2 \leq \frac{1}{2}\epsilon_0.$$

For  $u \in \mathcal{B}(4r, \xi, K)$  and  $j \in \{1, \dots, k\}$ , define the cutoff functions

$$\zeta_{u,j}(x) = \begin{cases} 1 & x \in B_{l_{u,j}}(\xi^j), \\ l_{u,j} + 1 - |x - \xi^j| & x \in \mathcal{N}_{u,j}^{int}, \\ 0 & x \in \mathbb{R}^n \setminus B_{l_{u,j}+1}(\xi^j), \end{cases}$$

and

$$\bar{\zeta}_{u,j}(x) = \begin{cases} 1 - \zeta_{u,j}(x) & x \in B_{\bar{l}_{u,j}}(\mathcal{U}_j), \\ 1 - \text{dist}(x, B_{\bar{l}_{u,j}}(\mathcal{U}_j)) & x \in \mathcal{N}_{u,j}^{ext}, \\ 0 & x \in \mathbb{R}^n \setminus B_{\bar{l}_{u,j}+1}(\mathcal{U}_j), \end{cases}$$

while for  $j \in \{k+1, \dots, M\}$ , set

$$\bar{\zeta}_{u,j}(x) = \begin{cases} 1 & x \in B_{\bar{l}_{u,j}}(\mathcal{U}_j), \\ 1 - \text{dist}(x, B_{\bar{l}_{u,j}}(\mathcal{U}_j)) & x \in \mathcal{N}_{u,j}^{ext}, \\ 0 & x \in \mathbb{R}^n \setminus B_{\bar{l}_{u,j}+1}(\mathcal{U}_j). \end{cases}$$

See Figures 4, 5. These cutoff functions will be used to study the contribution to the norm of  $u$  restricted to each of the sets,  $B_{l_{u,j}+1}(\xi^j)$ , where (roughly)  $u$  is near a single bump,  $f_{\xi^j}(K)$ , and each of the sets,  $A_u \cap \mathcal{U}_j$ , where  $u$  is near 0. The functions  $\bar{\zeta}_j$  for  $j = 1, \dots, M$ , have supports in regions where  $u$  is close to zero in contrast to the functions  $\zeta_j$  for  $j \in \{1, \dots, k\}$  which are supported on sets where  $u$  is close to the bump  $f_{\xi^j}(K)$ . For future reference, note that if  $\zeta$  is any one of the above cutoff functions, then  $0 \leq \zeta(x), |\nabla \zeta(x)| \leq 1$  a.e. on  $\mathbb{R}^n$ . A straightforward computation then shows if  $v \in E$  and  $\Omega$  is a measurable subset of  $\mathbb{R}^n$ ,  $\|\zeta v\|_{\Omega}^2 \leq 3\|v\|_{\Omega}^2$ .

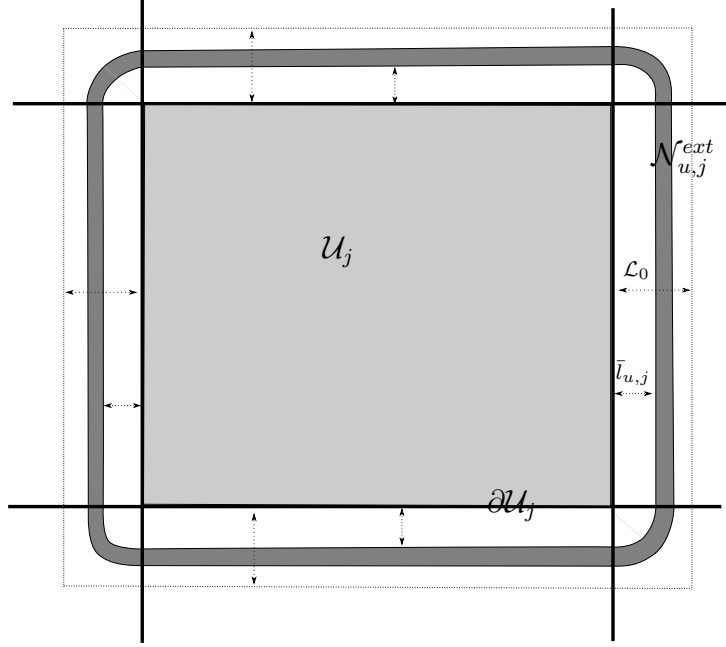
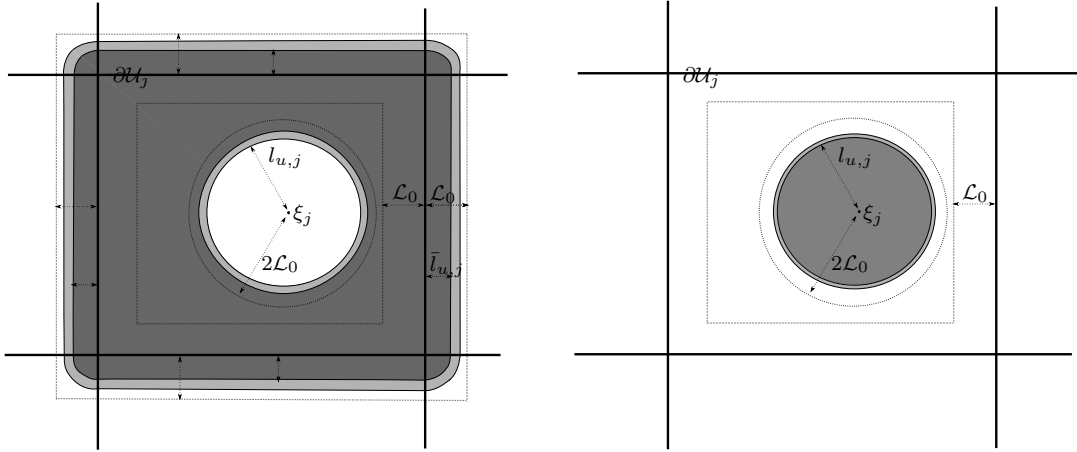

Figure 3:  $N_{u,j}^{ext}$ ,  $1 \leq j \leq M$ , is represented in dark gray. We have  $N_{u,j}^{ext} \subset B_{\mathcal{L}_0}(U_j) \setminus U_j$ .



Figures 4: A representation of  $\bar{\zeta}_{u,j}$  (on the left) and  $\zeta_{u,j}$  (on the right) for  $1 \leq j \leq k$ .  
In the dark gray region they are equal to 1, equal to 0 in the white region.

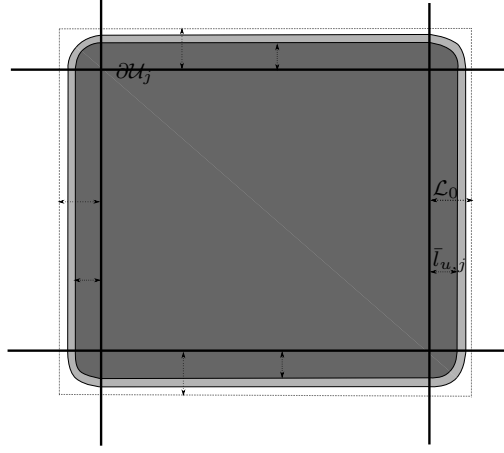

Figure 6: A representation of the functions  $\bar{\zeta}_{u,j}$  when  $k+1 \leq j \leq M$ . In the dark gray region they are equal to 1, equal to 0 in the white region.

The next proposition estimates  $J'_j(u)\bar{\zeta}_{u,i}u$  and  $J'(u)\bar{\zeta}_{u,i}u$ .

**Proposition 4.19.** *If  $u \in \mathcal{B}(4r, \xi, K)$ , then*

- 1°  $J'_j(u)\bar{\zeta}_{u,j}u \geq \frac{1}{2}\|u\|_{\mathcal{U}_j \cap A_u}^2 - \epsilon_0$  for  $1 \leq j \leq k$  and  $J'_j(u)\bar{\zeta}_{u,j}u \geq \frac{1}{2}\|u\|_{\mathcal{U}_j}^2$  for  $k+1 \leq j \leq M$ ;
- 2°  $J'(u)\bar{\zeta}_{u,j}u \geq \frac{1}{2}\|u\|_{\mathcal{U}_j \cap A_u}^2 - 2\epsilon_0$  for  $1 \leq j \leq k$  and  $J'(u)\bar{\zeta}_{u,j}u \geq \frac{1}{2}\|u\|_{\mathcal{U}_j}^2 - \epsilon_0$  for  $k+1 \leq j \leq M$ ;
- 3° if  $i \neq j \in \{1, \dots, M\}$  are such that the associated members of  $\mathbb{Z}^n \cap \mathcal{R}_\xi$  are  $p^i, p^j$  and  $\|p^i - p^j\| \leq 1$ , then  $J'_j(u)\bar{\zeta}_{u,i}u \geq -\epsilon_0$  while if  $\|p^i - p^j\| \geq 2$ , then  $J'_j(u)\bar{\zeta}_{u,i}u = 0$ .

**Proof:** To prove 1°, for  $u \in \mathcal{B}(4r, \xi, K)$ , an estimate is needed for

$$J'_j(u)\bar{\zeta}_{u,j}u = \langle u, \bar{\zeta}_{u,j}u \rangle_{\mathcal{U}_j} - \int_{\mathcal{U}_j} F_u(x, u)\bar{\zeta}_{u,j}u \, dx$$

for two ranges of values of the index  $j$ :  $1 \leq j \leq k$  and  $k+1 \leq j \leq M$ . Suppose first that  $1 \leq j \leq k$ . For such values of  $j$ ,

$$\bar{\zeta}_{u,j}(x) = 1 \text{ on } \mathcal{U}_j \setminus B_{l_{u,j+1}}(\xi^j) = \mathcal{U}_j \cap A_u, \quad \bar{\zeta}_{u,j}(x) = 0 \text{ on } B_{l_{u,j}}(\xi^j), \text{ and}$$

$$0 \leq \bar{\zeta}_{u,i}(x), |\nabla \bar{\zeta}_{u,i}(x)| \leq 1 \text{ for } x \in \mathcal{N}_{u,j}^{int} = B_{l_{u,j+1}}(\xi^j) \setminus B_{l_{u,j}}(\xi^j).$$

Consequently, to evaluate  $\langle u, \bar{\zeta}_{u,j} u \rangle_{\mathcal{U}_j} = \langle u, \bar{\zeta}_{u,j} u \rangle_{\mathcal{U}_j \cap A_u} + \langle u, \bar{\zeta}_{u,j} u \rangle_{\mathcal{N}_{u,j}^{int}}$ , observe that

$$\begin{aligned}
(4.20) \quad & \sum_{\iota=1}^m \int_{\mathcal{U}_j} \nabla u_\iota \cdot \nabla (\bar{\zeta}_{u,j} u_\iota) dx = \\
& = \sum_{\iota=1}^m \left( \int_{\mathcal{U}_j \cap A_u} |\nabla u_\iota|^2 dx + \int_{\mathcal{N}_{u,j}^{int}} \bar{\zeta}_{u,j} |\nabla u_\iota|^2 dx + \int_{\mathcal{N}_{u,j}^{int}} (\nabla u_\iota \cdot \nabla \bar{\zeta}_{u,j}) u_\iota dx \right) \\
& \geq \sum_{\iota=1}^m \left( \|\nabla u_\iota\|_{L^2(\mathcal{U}_j \cap A_u)}^2 - \|\nabla u\|_{L^2(\mathcal{N}_{u,j}^{int})} \|u\|_{L^2(\mathcal{N}_{u,j}^{int}, \mathbb{R}^m)} \right) \\
& \geq \sum_{\iota=1}^m \left( \|\nabla u_\iota\|_{L^2(\mathcal{U}_j \cap A_u)}^2 - \|u\|_{\mathcal{N}_{u,j}^{int}}^2 \right).
\end{aligned}$$

Since

$$(4.21) \quad \langle u, \bar{\zeta}_{u,j} u \rangle_{L^2(\mathcal{U}_j, \mathbb{R}^m)} \geq \|u\|_{L^2(\mathcal{U}_j \cap A_u, \mathbb{R}^m)}^2,$$

combining (4.20) and (4.21) and using (4.15) yields

$$(4.22) \quad \langle u, \bar{\zeta}_{u,j} u \rangle_{\mathcal{U}_j} \geq \|u\|_{\mathcal{U}_j \cap A_u}^2 - \frac{1}{2} \epsilon_0 \text{ for any } j \in \{1, \dots, k\}.$$

To complete the estimate of  $J'_j(u) \bar{\zeta}_{u,j} u$ , the contribution from  $\int_{\mathcal{U}_j} F_u(x, u) \bar{\zeta}_{u,j} u dx$  must also be taken into account. Towards this end, we first claim that for any  $v \in E$ ,

$$(4.23) \quad \int_{\mathcal{U}_j \setminus B_{l_{u,j}}(\xi^j)} |F_u(x, u)v| dx \leq \frac{1}{2} \|u\|_{\mathcal{U}_j \setminus B_{l_{u,j}}(\xi^j)} \|v\|_{\mathcal{U}_j \setminus B_{l_{u,j}}(\xi^j)}.$$

Indeed, by (4.13), (4.9), and (3.4),

$$\|u\|_{\mathcal{U}_j \setminus B_{l_{u,j}}(\xi^j)} < \bar{\rho}.$$

Thus, since the set  $\Omega = \mathcal{U}_j \setminus B_{l_{u,j}}(\xi^j)$  satisfies the cone property with respect to the cone  $\mathcal{T}$ , (4.23) follows from (2.9) in Remark 2.7. For future reference, note also that the same reasoning gives

$$(4.24) \quad \int_{\mathcal{U}_j \setminus B_{l_{u,j}}(\xi^j)} F(x, u) dx \leq \frac{1}{4} \|u\|_{\mathcal{U}_j \setminus B_{l_{u,j}}(\xi^j)}^2.$$

Using (4.15) and (4.23), shows for any  $j \in \{1, \dots, k\}$ ,

$$(4.25) \quad \int_{\mathcal{U}_j} |F_u(x, u) \bar{\zeta}_{u,j} u| dx \leq \int_{\mathcal{U}_j \setminus B_{\bar{t}_{u,j}}(\xi^j)} |F_u(x, u) u| dx \\ \leq \frac{1}{2} \|u\|_{\mathcal{U}_j \cap A_u}^2 + \frac{1}{2} \|u\|_{\mathcal{N}_{u,j}^{int}}^2 \leq \frac{1}{2} (\|u\|_{\mathcal{U}_j \cap A_u}^2 + \frac{1}{2} \epsilon_0).$$

Combining the estimates (4.22) and (4.25) then gives

$$(4.26) \quad J'_j(u) \bar{\zeta}_{u,j} u = \langle u, \bar{\zeta}_{u,j} u \rangle_{\mathcal{U}_j} - \int_{\mathcal{U}_j} F_u(x, u) \bar{\zeta}_{u,j} u dx \geq \frac{1}{2} \|u\|_{\mathcal{U}_j \cap A_u}^2 - \epsilon_0$$

and the first statement of 1<sup>o</sup> of Proposition 4.19 follows for  $j = 1, \dots, k$ .

When  $j \in \{k+1, \dots, M\}$ ,  $\bar{\zeta}_{u,j}(x) = 1$  and  $\nabla \bar{\zeta}_{u,j}(x) = 0$  for any  $x \in \mathcal{U}_j$ . Moreover  $\|u\|_{\mathcal{U}_j} \leq 4r < \bar{\rho}$  due to the definition of  $\mathcal{B}(4r, \xi, K)$ . Then as in (4.23),  $\int_{\mathcal{U}_j} |F_u(x, u) v| dx \leq \frac{1}{2} \|u\|_{\mathcal{U}_j} \|v\|_{\mathcal{U}_j}$ . Hence

$$J'_j(u) \bar{\zeta}_{u,j} u \geq \|u\|_{\mathcal{U}_j}^2 - \frac{1}{2} \|u\|_{\mathcal{U}_j}^2 = \frac{1}{2} \|u\|_{\mathcal{U}_j}^2 \text{ for any } j \in \{k+1, \dots, M\}$$

and the verification of 1<sup>o</sup> is complete.

To prove 2<sup>o</sup>, let  $u \in \mathcal{B}(4r, \xi, K)$  and  $1 \leq j \leq M$ . Then independently of the choice of  $j$ , due to the definition of  $\bar{\zeta}_{u,j}$ ,

$$\text{supp } \bar{\zeta}_{u,j} \subset \overline{B_{\bar{t}_{u,j+1}}(\mathcal{U}_j)} \text{ and } \bar{\zeta}_{u,j}(x) = 1 \text{ for } x \in B_{\bar{t}_{u,j}}(\mathcal{U}_j) \setminus \mathcal{U}_j.$$

Hence,

$$(4.27) \quad J'(u) \bar{\zeta}_{u,j} u = \\ = J'_j(u) \bar{\zeta}_{u,j} u + \langle u, \bar{\zeta}_{u,j} u \rangle_{B_{\bar{t}_{u,j+1}}(\mathcal{U}_j) \setminus \mathcal{U}_j} - \int_{B_{\bar{t}_{u,j+1}}(\mathcal{U}_j) \setminus \mathcal{U}_j} F_u(x, u) \bar{\zeta}_{u,j} u dx \\ = J'_j(u) \bar{\zeta}_{u,j} u + \|u\|_{B_{\bar{t}_{u,j}}(\mathcal{U}_j) \setminus \mathcal{U}_j}^2 - \int_{B_{\bar{t}_{u,j}}(\mathcal{U}_j) \setminus \mathcal{U}_j} F_u(x, u) u dx + \\ + \langle u, \bar{\zeta}_{u,j} u \rangle_{\mathcal{N}_{u,j}^{ext}} - \int_{\mathcal{N}_{u,j}^{ext}} F_u(x, u) \bar{\zeta}_{u,j} u dx.$$

Lower bounds for the first term on the right hand side of (4.27) are provided by 1<sup>o</sup>, so 2<sup>o</sup> follows from (4.27) once we show that for  $1 \leq j \leq M$ ,

$$(4.28) \quad \|u\|_{B_{\bar{t}_{u,j}}(\mathcal{U}_j) \setminus \mathcal{U}_j}^2 - \int_{B_{\bar{t}_{u,j}}(\mathcal{U}_j) \setminus \mathcal{U}_j} F_u(x, u) u dx \geq 0$$

$$(4.29) \quad \langle u, \bar{\zeta}_{u,j} u \rangle_{\mathcal{N}_{u,j}^{ext}} - \int_{\mathcal{N}_{u,j}^{ext}} F_u(x, u) \bar{\zeta}_{u,j} u dx \geq -\epsilon_0.$$

The inequality (4.28) involves the behaviour of  $u$  on the set  $B_{\bar{l}_{u,j}}(\mathcal{U}_j) \setminus \mathcal{U}_j$ . This set can be decomposed as follows:

$$B_{\bar{l}_{u,j}}(\mathcal{U}_j) \setminus \mathcal{U}_j = \cup_{i \neq j} \mathcal{U}_i \cap (B_{\bar{l}_{u,j}}(\mathcal{U}_j) \setminus \mathcal{U}_j).$$

By (4.17), since  $\bar{l}_{u,j} \leq \mathcal{L}_0 - 1$ ,

$$\|u\|_{\mathcal{U}_i \cap (B_{\bar{l}_{u,j}+1}(\mathcal{U}_j) \setminus \mathcal{U}_j)} \leq 5r < \bar{\rho} \text{ for any } i \neq j \text{ such that } \mathcal{U}_i \cap B_{\mathcal{L}_0}(\mathcal{U}_j) \neq \emptyset.$$

Then again as for (4.23), for any  $i \neq j$  such that  $\mathcal{U}_i \cap B_{\mathcal{L}_0}(\mathcal{U}_j) \neq \emptyset$ , we have

$$\int_{\mathcal{U}_i \cap (B_{\bar{l}_{u,j}}(\mathcal{U}_j) \setminus \mathcal{U}_j)} |F_u(x, u)u| dx \leq \frac{1}{2} \|u\|_{\mathcal{U}_i \cap (B_{\bar{l}_{u,j}}(\mathcal{U}_j) \setminus \mathcal{U}_j)}^2$$

from which it follows that

$$\begin{aligned} & \|u\|_{B_{\bar{l}_{u,j}}(\mathcal{U}_j) \setminus \mathcal{U}_j}^2 - \int_{B_{\bar{l}_{u,j}}(\mathcal{U}_j) \setminus \mathcal{U}_j} F_u(x, u)u dx = \\ & = \sum_{i \neq j} (\|u\|_{\mathcal{U}_i \cap (B_{\bar{l}_{u,j}}(\mathcal{U}_j) \setminus \mathcal{U}_j)}^2 - \int_{\mathcal{U}_i \cap (B_{\bar{l}_{u,j}}(\mathcal{U}_j) \setminus \mathcal{U}_j)} F_u(x, u)u dx) \geq 0, \end{aligned}$$

i.e. (4.28) follows. A similar argument proves (4.29), namely by (4.18),  $\|u\|_{\mathcal{N}_{u,i}^{ext}}^2 \leq \frac{1}{2} \epsilon_0 < \rho$  so as for (4.23),

$$\int_{\mathcal{N}_{u,j}^{ext}} |F_u(x, u) \bar{\zeta}_{u,j} u| dx \leq \int_{\mathcal{N}_{u,j}^{ext}} |F_u(x, u)u| dx \leq \frac{1}{2} \|u\|_{\mathcal{N}_{u,i}^{ext}}^2 \leq \frac{1}{4} \epsilon_0.$$

Moreover, since  $\bar{\zeta}_{u,j} \geq 0$ ,  $\langle u, \bar{\zeta}_{u,j} u \rangle_{L^2(\mathcal{N}_{u,j}^{ext}; \mathbb{R}^m)} \geq 0$ , so as for (4.20),

$$\begin{aligned} \langle u, \bar{\zeta}_{u,j} u \rangle_{\mathcal{N}_{u,j}^{ext}} & \geq \sum_{\iota=1}^m \int_{\mathcal{N}_{u,j}^{ext}} \nabla u_\iota \nabla (\bar{\zeta}_{u,j} u_\iota) dx \\ & = \sum_{\iota=1}^m \int_{\mathcal{N}_{u,j}^{ext}} \bar{\zeta}_{u,j} |\nabla u_\iota|^2 dx + \int_{\mathcal{N}_{u,j}^{ext}} (\nabla u_\iota \cdot \nabla \bar{\zeta}_{u,j}) u_\iota dx \\ & \geq -\|\nabla u\|_{L^2(\mathcal{N}_{u,j}^{ext})} \|u\|_{L^2(\mathcal{N}_{u,j}^{ext}; \mathbb{R}^m)} \geq -\|u\|_{\mathcal{N}_{u,j}^{ext}}^2 \geq -\frac{1}{2} \epsilon_0. \end{aligned}$$

Thus using the results of the last two inequalities shows

$$\langle u, \bar{\zeta}_{u,j} u \rangle_{\mathcal{N}_{u,j}^{ext}} - \int_{\mathcal{N}_{u,j}^{ext}} F_u(x, u) \bar{\zeta}_{u,j} u dx \geq -\epsilon_0,$$

i.e. (4.29) and completing the proof of 2<sup>o</sup>.

Lastly 3<sup>o</sup> will be established. Let  $u \in \mathcal{B}(4r, \xi, K)$ , and  $i, j \in \{1, \dots, M\}$  with  $i \neq j$ . By (iv) of Lemma 3.10, if  $\|p^i - p^j\| \geq 2$ , then  $B_{\mathcal{L}_0}(\mathcal{U}_i) \cap \mathcal{U}_j = \emptyset$ . Hence  $\bar{\zeta}_{u,i}(x) = 0$  for any  $x \in \mathcal{U}_j$  and  $J'_j(u)\bar{\zeta}_{u,i}u = 0$  as stated in the second part of 3<sup>o</sup>.

Thus assume  $\|p^i - p^j\| \leq 1$ . To estimate

$$J'_j(u)\bar{\zeta}_{u,i}u = \langle u, \bar{\zeta}_{u,i}u \rangle_{\mathcal{U}_j} - \int_{\mathcal{U}_j} F_u(x, u)\bar{\zeta}_{u,i}u \, dx,$$

recall that by the definition of  $\bar{\zeta}_{u,i}$ , for any  $i \in \{1, \dots, M\}$ ,

- (i)  $\text{supp } \bar{\zeta}_{u,i} \subset B_{\bar{l}_{u,i}}(\mathcal{U}_i) \cup \mathcal{N}_{u,i}^{ext}$ ,
- (ii)  $\bar{\zeta}_{u,i}(x) = 1$  for  $x \in B_{\bar{l}_{u,i}}(\mathcal{U}_i) \setminus \mathcal{U}_i$ ,
- (iii)  $0 \leq \bar{\zeta}_{u,i}(x)$ ,  $|\nabla \bar{\zeta}_{u,i}(x)| \leq 1$  for  $x \in \mathcal{N}_{u,i}^{ext}$ .

By property (i),

$$J'_j(u)\bar{\zeta}_{u,i}u = \langle u, \bar{\zeta}_{u,i}u \rangle_{\mathcal{U}_j \cap (B_{\bar{l}_{u,i}}(\mathcal{U}_i) \cup \mathcal{N}_{u,i}^{ext})} - \int_{\mathcal{U}_j \cap (B_{\bar{l}_{u,i}}(\mathcal{U}_i) \cup \mathcal{N}_{u,i}^{ext})} F_u(x, u)\bar{\zeta}_{u,i}u \, dx.$$

By (ii),  $\bar{\zeta}_{u,i}(x) = 1$  for  $x \in \mathcal{U}_j \cap B_{\bar{l}_{u,i}}(\mathcal{U}_i)$  so the scalar product term can be written as

$$\langle u, \bar{\zeta}_{u,i}u \rangle_{\mathcal{U}_j \cap (B_{\bar{l}_{u,i}}(\mathcal{U}_i) \cup \mathcal{N}_{u,i}^{ext})} = \|u\|_{\mathcal{U}_j \cap B_{\bar{l}_{u,i}}(\mathcal{U}_i)}^2 + \langle u, \bar{\zeta}_{u,i}u \rangle_{\mathcal{U}_j \cap \mathcal{N}_{u,i}^{ext}}.$$

Moreover  $0 \leq \bar{\zeta}_{u,i}(x)$  for  $x \in \mathcal{U}_j \cap \mathcal{N}_{u,i}^{ext}$  via (iii) so  $\langle u, \bar{\zeta}_{u,i}u \rangle_{L^2(\mathcal{U}_j \cap \mathcal{N}_{u,i}^{ext}, \mathbb{R}^m)} \geq 0$ . Then, since again by (iii),  $|\nabla \bar{\zeta}_{u,i}(x)| \leq 1$  for  $x \in \mathcal{U}_j \cap \mathcal{N}_{u,i}^{ext}$ , using (4.18) as in (4.20) leads to

$$\begin{aligned} \langle u, \bar{\zeta}_{u,i}u \rangle_{\mathcal{U}_j \cap \mathcal{N}_{u,i}^{ext}} &\geq \sum_{\iota=1}^m \int_{\mathcal{U}_j \cap \mathcal{N}_{u,i}^{ext}} \nabla u_\iota \cdot \nabla(\bar{\zeta}_{u,i}u_\iota) \, dx = \\ &= \sum_{\iota=1}^m \int_{\mathcal{U}_j \cap \mathcal{N}_{u,i}^{ext}} \bar{\zeta}_{u,i} |\nabla u_\iota|^2 \, dx + \int_{\mathcal{U}_j \cap \mathcal{N}_{u,i}^{ext}} (\nabla u_\iota \cdot \nabla \bar{\zeta}_{u,i}) u_\iota \, dx \\ &\geq -\|\nabla u\|_{L^2(\mathcal{U}_j \cap \mathcal{N}_{u,i}^{ext})} \|u\|_{L^2(\mathcal{U}_j \cap \mathcal{N}_{u,i}^{ext}, \mathbb{R}^m)} \\ &\geq -\|u\|_{\mathcal{U}_j \cap \mathcal{N}_{u,i}^{ext}}^2 \geq -\frac{1}{2}\epsilon_0. \end{aligned}$$

Combining the two above inequalities yields

$$(4.30) \quad \langle u, \bar{\zeta}_{u,i} u \rangle_{\mathcal{U}_j} \geq \|u\|_{\mathcal{U}_j \cap B_{\bar{r}_{u,i}}(\mathcal{U}_i)}^2 - \frac{1}{2}\epsilon_0.$$

To complete the lower bound for  $J'_j(u)\bar{\zeta}_{u,i}u$ , an estimate is needed for

$$\int_{\mathcal{U}_j \cap (B_{\bar{r}_{u,i}}(\mathcal{U}_i) \cup \mathcal{N}_{u,i}^{ext})} F_u(x, u) \bar{\zeta}_{u,i} u \, dx = \int_{\mathcal{U}_j \cap B_{\bar{r}_{u,i+1}}(\mathcal{U}_i)} F_u(x, u) \bar{\zeta}_{u,i} u \, dx$$

For this purpose, observe first that due to (4.17),

$$(4.31) \quad \|u\|_{\mathcal{U}_j \cap B_{\mathcal{L}_0}(\mathcal{U}_i)} \leq 5r < \bar{\rho}.$$

Thus since  $\bar{l}_{u,i} + 1 \leq \mathcal{L}_0$ , as for (4.23), for any  $v \in E$ ,

$$(4.32) \quad \int_{\mathcal{U}_j \cap B_{\bar{r}_{u,i+1}}(\mathcal{U}_i)} |F_u(x, u)v| \, dx \leq \frac{1}{2} \|u\|_{\mathcal{U}_j \cap B_{\bar{r}_{u,i+1}}(\mathcal{U}_i)} \|v\|_{\mathcal{U}_j \cap B_{\bar{r}_{u,i+1}}(\mathcal{U}_i)}.$$

Then by (4.18) and (4.32),

$$(4.33) \quad \begin{aligned} \int_{\mathcal{U}_j \cap B_{\bar{r}_{u,i+1}}(\mathcal{U}_i)} |F_u(x, u) \bar{\zeta}_{u,i} u| \, dx &\leq \int_{\mathcal{U}_j \cap B_{\bar{r}_{u,i+1}}(\mathcal{U}_i)} |F_u(x, u) u| \, dx \\ &\leq \frac{1}{2} \|u\|_{\mathcal{U}_j \cap B_{\bar{r}_{u,i}}(\mathcal{U}_i)}^2 + \frac{1}{2} \|u\|_{\mathcal{U}_j \cap \mathcal{N}_{u,i}^{ext}}^2 \leq \frac{1}{2} (\|u\|_{\mathcal{U}_j \cap B_{\bar{r}_{u,i}}(\mathcal{U}_i)}^2 + \frac{1}{2}\epsilon_0). \end{aligned}$$

By (4.30) and (4.33), if  $i \neq j \in \{1, \dots, M\}$  are such that  $\|p^i - p^j\| \leq 1$ , then

$$(4.34) \quad J'_j(u)\bar{\zeta}_{u,i}u = \langle u, \bar{\zeta}_{u,i}u \rangle_{\mathcal{U}_j} - \int_{\mathcal{U}_j} F_u(x, u) \bar{\zeta}_{u,i} u \, dx \geq \frac{1}{2} \|u\|_{\mathcal{U}_j \cap B_{\bar{r}_{u,i}}(\mathcal{U}_i)}^2 - \epsilon_0.$$

Thus the proof of 3<sup>o</sup> and Proposition 4.19 is complete.

To investigate the properties of  $J'(u)$  further and in particular to prepare for the verification of 2<sup>o</sup> of Proposition 4.1, use will be made of (A) of Proposition 3.1. For each  $u \in \mathcal{B}(4r, \xi, K)$ , consider the set of indices

$$\begin{aligned} \mathcal{I}_1(u) = \{j \in \{1, \dots, M\} \mid \text{either} \\ 1 \leq j \leq k, 4r > \|u - f_{\xi^j}(K)\|_{\mathcal{U}_j} \geq 3r \text{ and } |J_j(u) - \bar{c}| \leq \frac{3}{2}\lambda(r) \text{ or} \\ k+1 \leq j \leq M \text{ and } 4r > \|u\|_{\mathcal{U}_j} \geq 3r.\} \end{aligned}$$

If  $j \in \mathcal{I}_1(u)$ , either

$$(a) \|u\|_{\mathcal{U}_j \cap A_u} \geq \frac{1}{2} \min\{r, \lambda(r)^{1/2}\} \quad \text{or} \quad (b) \|u\|_{\mathcal{U}_j \cap A_u} < \frac{1}{2} \min\{r, \lambda(r)^{1/2}\}.$$

For  $\sigma \in \{a, b\}$  let

$$\mathcal{I}_1^{(\sigma)}(u) = \{j \in \mathcal{I}_1(u) \mid \text{case } (\sigma) \text{ occurs}\}.$$

Note that by construction  $\mathcal{U}_j \cap A_u = \mathcal{U}_j$  for any  $j \in \{k+1, \dots, M\}$ . Hence, if  $j \geq k+1$  and  $j \in \mathcal{I}_1(u)$ , then  $\|u\|_{\mathcal{U}_j \cap A_u} = \|u\|_{\mathcal{U}_j} \geq 3r$ . Thus case (a) always occurs when  $j \in \{k+1, \dots, M\} \cap \mathcal{I}_1(u)$ . Consequently

$$(4.35) \quad \mathcal{I}_1^{(b)}(u) \subset \{1, \dots, k\} \cap \mathcal{I}_1(u).$$

Note now that due to the choice of  $\mu_1, \epsilon_0 < \frac{1}{100} \min\{r^2, \lambda(r)\}$ . Therefore if  $j \in \mathcal{I}_1^{(a)}(u)$ , by 1<sup>o</sup> and 2<sup>o</sup> of Proposition 4.19,

$$(4.36) \quad J'_j(u) \bar{\zeta}_{u,j} u > \frac{1}{10} \min\{r^2, \lambda(r)\} \quad \text{and} \quad J'(u) \bar{\zeta}_{u,j} u > \frac{1}{10} \min\{r^2, \lambda(r)\}.$$

When (b) holds, the next result provides more information about  $\zeta_{u,j}u$ :

**Proposition 4.37.** *If  $u \in \mathcal{B}(4r, \xi, K)$  and  $j \in \mathcal{I}_1^{(b)}(u)$ , then*

$$(4.38) \quad \zeta_{u,j}u \in B_{10r}(f_{\xi^j}(K)) \setminus B_r(f_{\xi^j}(K)),$$

$$(4.39) \quad |J_j(\zeta_{u,j}u) - \bar{c}| < 2\lambda(r),$$

and there exists a  $Z_{u,j}^{(1)} \in E$  with  $\|Z_{u,j}^{(1)}\| \leq 1$  for which

$$(4.40) \quad J'(u) \zeta_{u,j} Z_{u,j}^{(1)} = J'_j(u) \zeta_{u,j} Z_{u,j}^{(1)} \geq \frac{\mu_r}{2}.$$

**Proof.** First note that since  $j \in \mathcal{I}_1^{(b)}(u)$ , (4.35) shows  $1 \leq j \leq k$  so  $\zeta_{u,j}$  is well defined. To verify (4.38), recall that  $\text{supp } \zeta_{u,j} \subset B_{l_{u,j}+1}(\xi^j)$ . Hence

$$(4.41) \quad \begin{aligned} \|\zeta_{u,j}u - f_{\xi^j}(K)\|^2 &\leq \|\zeta_{u,j}u - f_{\xi^j}(K)\|_{B_{l_{u,j}+1}(\xi^j)}^2 \\ &\quad + \sup_{v \in f_{\xi^j}(K)} \|v\|_{\mathbb{R}^n \setminus B_{l_{u,j}+1}(\xi^j)}^2. \end{aligned}$$

The second term on the right hand side of (4.41) can be bounded via (4.10). To estimate the first term on the right, observe that since  $\zeta_{u,j} = 1$  on  $B_{l_{u,j}}(\xi_j)$ ,

$$(4.42) \quad \begin{aligned} \|\zeta_{u,j}u - f_{\xi^j}(K)\|_{B_{l_{u,j}+1}(\xi^j)}^2 &= \|u - f_{\xi^j}(K)\|_{B_{l_{u,j}}(\xi^j)}^2 \\ &\quad + \|\zeta_{u,j}u - f_{\xi^j}(K)\|_{\mathcal{N}_{u,j}^{int}}^2. \end{aligned}$$

The inequality

$$\|u - f_{\xi^j}(K)\|_{B_{l_{u,j}}(\xi^j)}^2 \leq (4r)^2 \text{ for } u \in \mathcal{B}(4r, \xi, K)$$

provides a bound for the first term on the right in (4.42) while for the second, we have

$$(4.43) \quad \|\zeta_{u,j}u - f_{\xi^j}(K)\|_{\mathcal{N}_{u,j}^{int}}^2 \leq 2\|\zeta_{u,j}u\|_{\mathcal{N}_{u,j}^{int}}^2 + 2 \sup_{v \in f_{\xi^j}(K)} \|v\|_{\mathcal{N}_{u,j}^{int}}^2.$$

The right hand side of (4.43) can be bounded via (4.15) and (4.10). Combining these observations with the choice of  $\varepsilon_0$  gives

$$(4.44) \quad \|\zeta_{u,j}u - f_{\xi^j}(K)\|^2 \leq (4r)^2 + 10\varepsilon_0 < (10r)^2.$$

Now to complete the proof of (4.38), it remains to show that if case (b) occurs, then

$$\|\zeta_{u,j}u - f_{\xi^j}(K)\| > r.$$

To obtain this estimate, observe that by (b) and (4.10),

$$\|u - f_{\xi^j}(K)\|_{\mathcal{U}_j \cap A_u} \leq \|u\|_{\mathcal{U}_j \cap A_u} + \sup_{v \in f_{\xi^j}(K)} \|v\|_{\mathcal{U}_j \cap A_u} \leq \frac{1}{2}r + \varepsilon_0.$$

Since  $j \in \mathcal{I}_1^b(u)$ , as was noted above,  $1 \leq j \leq k$  and also  $\|u - f_{\xi^j}(K)\|_{\mathcal{U}_j}^2 \geq (3r)^2$ . Hence by (4.9),

$$(4.45) \quad \|u - f_{\xi^j}(K)\|_{\mathcal{U}_j \setminus A_u}^2 \geq (3r)^2 - (\frac{1}{2}r + \varepsilon_0)^2 > 8r^2.$$

Observing that

$$\mathcal{U}_j \setminus A_u = B_{l_{u,j}+1}(\xi_j) = B_{l_{u,j}}(\xi_j) \cup \mathcal{N}_{u,j}^{int}$$

and that  $\zeta_{u,j} = 1$  on  $B_{l_{u,j}}(\xi_j)$ , we have

$$\|(1 - \zeta_{u,j})u\|_{\mathcal{U}_j \setminus A_u} = \|(1 - \zeta_{u,j})u\|_{\mathcal{N}_{u,j}^{int}} \leq \sqrt{3}\|u\|_{\mathcal{N}_{u,j}^{int}}.$$

Thus by (4.45), (4.15) and (4.9),

$$\begin{aligned} \|\zeta_{u,j}u - f_{\xi^j}(K)\| &\geq \|\zeta_{u,j}u - f_{\xi^j}(K)\|_{\mathcal{U}_j \setminus A_u} \\ &\geq \|u - f_{\xi^j}(K)\|_{\mathcal{U}_j \setminus A_u} - \|(1 - \zeta_{u,j})u\|_{\mathcal{U}_j \setminus A_u} \\ &\geq \|u - f_{\xi^j}(K)\|_{\mathcal{U}_j \setminus A_u} - \sqrt{3}\|u\|_{\mathcal{N}_{u,j}^{int}} > r \end{aligned}$$

and (4.38) follows.

To verify (4.39), note that since  $j \in \mathcal{I}_1(u) \cap \{1, \dots, k\}$ ,  $|J_j(u) - \bar{c}| \leq \frac{3}{2}\lambda(r)$ . Hence it suffices to show that  $|J_j(u) - J(\zeta_{u,j}u)| < \frac{1}{2}\lambda(r)$ . Recalling that  $\text{supp } \zeta_{u,j} \subset \mathcal{U}_j \setminus A_u$  and  $\zeta_{u,j}(x) = 1$  on  $\mathcal{U}_j \setminus (A_u \cup \mathcal{N}_{u,j}^{int})$  leads to

$$\begin{aligned} |J_j(u) - J(\zeta_{u,j}u)| &\leq \left| \frac{1}{2}\|u\|_{\mathcal{U}_j}^2 - \frac{1}{2}\|\zeta_{u,j}u\|^2 \right| + \int_{\mathcal{U}_j} |F(x, \zeta_{u,j}u) - F(x, u)| dx \\ &\leq \frac{1}{2}\|u\|_{\mathcal{U}_j \cap A_u}^2 + \frac{1}{2}\|u\|_{\mathcal{N}_{u,j}^{int}}^2 + \frac{1}{2}\|\zeta_{u,j}u\|_{\mathcal{N}_{u,j}^{int}}^2 + \\ &\quad + \int_{\mathcal{N}_{u,j}^{int}} F(x, \zeta_{u,j}u) + F(x, u) dx + \int_{\mathcal{U}_j \cap A_u} F(x, u) dx. \end{aligned}$$

We will estimate each of the terms on the right hand side of this inequality. Observe that

- 1<sup>o</sup>  $\|u\|_{\mathcal{U}_j \cap A_u} \leq \frac{1}{2} \min\{r, \lambda(r)^{1/2}\} < \bar{\rho}$  via (b) and (3.4);
- 2<sup>o</sup>  $\|\zeta_{u,j}u\|_{\mathcal{N}_{u,j}^{int}}^2 \leq 3\|u\|_{\mathcal{N}_{u,j}^{int}}^2 \leq 3\epsilon_0/2$  by (4.15);
- 3<sup>o</sup>  $\int_{\mathcal{N}_{u,j}^{int}} F(x, u) dx \leq \frac{1}{16}\lambda(r)$  by applying (4.24) with  $\mathcal{U}_j \cap A_u$  replaced by  $\mathcal{N}_{u,j}^{int}$ ;
- 4<sup>o</sup>  $\int_{\mathcal{N}_{u,j}^{int}} F(x, \zeta_{u,j}u) dx \leq \frac{1}{16}\lambda(r)$  as in item 3<sup>o</sup>;
- 5<sup>o</sup>  $\int_{\mathcal{U}_j \cap A_u} F(x, u) dx \leq \frac{1}{4}\|u\|_{\mathcal{U}_j \cap A_u}^2 \leq \frac{1}{16}\lambda(r)$  by (4.24) and 1<sup>o</sup>.

To obtain the estimate for  $\int_{\mathcal{N}_{u,j}^{int}} F(x, \zeta_{u,j}u) dx$ , the fact that  $\|\zeta_{u,j}u\|_{\mathcal{N}_{u,j}^{int}} \leq \bar{\rho}$  was used. Combining these estimates and using (4.9) yields

$$|J_j(u) - J(\zeta_{u,j}u)| \leq \frac{5}{16}\lambda(r) + 2\epsilon_0 < \frac{1}{2}\lambda(r)$$

and (4.39) is proved.

Now that (4.38) - (4.39) hold, property (A) in Proposition 3.1 can be invoked giving a  $Z_{u,j}^{(1)} \in E$  with  $\|Z_{u,j}^{(1)}\| \leq 1$  such that  $J'(\zeta_{u,j}u)Z_{u,j}^{(1)} \geq \mu_r$ . Thus (4.40) follows once it is shown that

$$(4.46) \quad |J'(u)\zeta_{u,j}Z_{u,j}^{(1)} - J'(\zeta_{u,j}u)Z_{u,j}^{(1)}| \leq \mu_r/2.$$

To verify (4.46), observe that

$$\begin{aligned} & |J'(u)\zeta_{u,j}Z_{u,j}^{(1)} - J'(\zeta_{u,j}u)Z_{u,j}^{(1)}| \\ & \leq |\langle u, \zeta_{u,j}Z_{u,j}^{(1)} \rangle - \langle \zeta_{u,j}u, Z_{u,j}^{(1)} \rangle| + \int_{\mathbb{R}^n} |F_u(x, \zeta_{u,j}u)Z_{u,j}^{(1)} - F_u(x, u)\zeta_{u,j}Z_{u,j}^{(1)}| dx \\ & = |\langle u, \zeta_{u,j}Z_{u,j}^{(1)} \rangle_{\mathcal{N}_{u,j}^{int}} - \langle \zeta_{u,j}u, Z_{u,j}^{(1)} \rangle_{\mathcal{N}_{u,j}^{int}}| + \int_{\mathcal{N}_{u,j}^{int}} |F_u(x, \zeta_{u,j}u)Z_{u,j}^{(1)} - F_u(x, u)\zeta_{u,j}Z_{u,j}^{(1)}| dx \\ & \leq 3\sqrt{3}\|u\|_{\mathcal{N}_{u,j}^{int}} \leq 4\sqrt{\varepsilon_0} \end{aligned}$$

where item 2<sup>o</sup> as well as the analogies of items 4<sup>o</sup> – 5<sup>o</sup> for  $F_u$  were used. Now (4.46) follows via (4.9) and the definition of  $\mu_1$  in (4.8).

Next, as the third step in the proof, we will prepare for the proof of 3<sup>o</sup> of Proposition 4.1. This discussion parallels what was just done in preparation for 2<sup>o</sup>. Let  $\lambda_{\pm}, \lambda_0$  be as in (P1) and  $u \in \mathcal{B}(4r, \xi, K)$ . Consider the set of indices

$$\begin{aligned} \mathcal{I}_2(u) = \{j \in \{1, \dots, M\} \setminus \mathcal{I}_1(u) \mid & \text{either} \\ & 1 \leq j \leq k \text{ and } J_j(u) - \bar{c} \in (\lambda_- - 2\lambda_0, \lambda_- + 2\lambda_0) \cup (\lambda_+ - 2\lambda_0, \lambda_+ + 2\lambda_0) \text{ or} \\ & k+1 \leq j \leq M \text{ and } J_j(u) \in [\lambda_+ - 2\lambda_0, \lambda_+ + 2\lambda_0]\}. \end{aligned}$$

For  $j \in \mathcal{I}_2(u)$ , either

$$(a) \|u\|_{\mathcal{U}_j \cap A_u} \geq \frac{1}{2} \min\{r, \lambda_0^{1/2}\} \quad \text{or} \quad (b) \|u\|_{\mathcal{U}_j \cap A_u} < \frac{1}{2} \min\{r, \lambda_0^{1/2}\}.$$

For  $\sigma \in \{a, b\}$ , let

$$\mathcal{I}_2^{(\sigma)}(u) = \{j \in \mathcal{I}_2(u) \mid \text{case } (\sigma) \text{ occurs}\}.$$

As in the previous case,

$$(4.47) \quad \mathcal{I}_2^{(b)}(u) \subset \{1, \dots, k\} \cap \mathcal{I}_2(u).$$

Indeed assume that  $j \in \mathcal{I}_2(u) \cap \{k+1, \dots, M\}$ . Since  $j \geq k+1$ ,  $\mathcal{U}_j \cap A_u = \mathcal{U}_j$ . In addition, since  $j \in \mathcal{I}_2(u) \cap \{k+1, \dots, M\}$ , by definition,

$$J_j(u) \geq \lambda_+ - 2\lambda_0 > \frac{1}{8}\lambda_0.$$

Since  $J_j(u) \leq \frac{1}{2}\|u\|_{\mathcal{U}_j}^2$ , the above two observations give

$$\|u\|_{\mathcal{U}_j \cap A_u}^2 = \|u\|_{\mathcal{U}_j}^2 \geq 2J_j(u) > \frac{1}{4}\lambda_0,$$

showing that case (a) always occurs when  $j \in \mathcal{I}_2(u) \cap \{k+1, \dots, M\}$  and (4.47) follows.

If  $j \in \mathcal{I}_2^{(a)}(u)$ , since  $\epsilon_0 < \frac{1}{100} \min\{r^2, \lambda_0\}$ , by 1<sup>o</sup> and 2<sup>o</sup> of Proposition 4.19,

$$(4.48) \quad J'_j(u)\bar{\zeta}_{u,j}u > \frac{1}{10} \min\{r^2, \lambda_0\} \text{ and } J'(u)\bar{\zeta}_{u,j}u > \frac{1}{10} \min\{r^2, \lambda_0\}.$$

When case (b) occurs, there is an analogue of Proposition 4.37:

**Proposition 4.49.** *If  $u \in \mathcal{B}(4r, \xi, K)$  and  $j \in \mathcal{I}_2^{(b)}(u)$ , then*

$$(4.50) \quad \zeta_{u,j}u \in B_{10r}(f_{\xi^j}(K)),$$

$$(4.51) \quad J_j(\zeta_{u,j}u) - \bar{c} \in (\lambda_- - 4\lambda_0, \lambda_- + 4\lambda_0) \cup (\lambda_+ - 4\lambda_0, \lambda_+ + 4\lambda_0),$$

and there exists a  $Z_{u,j}^{(2)} \in E$  with  $\|Z_{u,j}^{(2)}\| \leq 1$  such that

$$(4.52) \quad J'(u)\zeta_{u,j}Z_{u,j}^{(2)} = J'_j(u)\zeta_{u,j}Z_{u,j}^{(2)} \geq \frac{\nu}{2}.$$

**Proof.** Since several arguments are the same as in the proof of Proposition 4.37, we will be brief. Note again that since  $j \in \mathcal{I}_2^{(b)}(u)$  by (4.47),  $1 \leq j \leq k$ , so  $\zeta_{u,j}$  is well defined and

$$(4.53) \quad J_j(u) - \bar{c} \in (\lambda_- - 2\lambda_0, \lambda_- + 2\lambda_0) \cup (\lambda_+ - 2\lambda_0, \lambda_+ + 2\lambda_0).$$

As a consequence of (i) of (P1) in Section 3,

$$(4.54) \quad (\lambda_{\pm} - 2\lambda_0, \lambda_{\pm} + 2\lambda_0) \subset \left(-\frac{3}{2}\lambda(r), \frac{3}{2}\lambda(r)\right).$$

Combining (4.54) and (4.53) shows

$$(4.55) \quad |J_j(u) - \bar{c}| \leq \frac{3}{2}\lambda(r).$$

Now (4.55) and  $j \in \mathcal{I}^{(b)}(u)$  imply  $\|u - f_{\xi^j}(K)\|_{\mathcal{U}_j} < 3r$  for otherwise  $j \in \mathcal{I}_1(u)$ . The estimates which led to (4.44) in the proof of Proposition 4.37 can be used here to get (4.50) and will be omitted. Next to prove (4.51), it suffices to show that

$$(4.56) \quad |J_j(u) - J(\zeta_{u,j}u)| \leq 2\lambda_0.$$

The verification of (4.56) follows the same lines of that of (4.39). Again we have

$$\begin{aligned} |J_j(u) - J(\zeta_{u,j}u)| &\leq \frac{1}{2}\|u\|_{\mathcal{U}_j \cap A_u}^2 + \frac{1}{2}\|u\|_{\mathcal{N}_{u,j}^{int}}^2 + \frac{1}{2}\|\zeta_{u,j}u\|_{\mathcal{N}_{u,j}^{int}}^2 + \\ &\quad + \int_{\mathcal{N}_{u,j}^{int}} F(x, \zeta_{u,j}u) + F(x, u) dx + \int_{\mathcal{U}_j \cap A_u} F(x, u) dx. \end{aligned}$$

By (b),  $\|u\|_{\mathcal{U}_j \cap A_u} \leq \frac{1}{2} \min\{r, \lambda_0^{1/2}\} < \bar{\rho}$  so item 1<sup>o</sup> in the proof of Proposition 4.37 holds. Analogues of the remaining items follow in a similar fashion and (4.56) obtains. Now to verify (4.52), by (4.50), (4.51) and property (P1), whenever  $u \in \mathcal{B}(4r, \xi, K)$  and  $j \in \mathcal{I}_2^{(b)}(u)$ , there exists a  $Z_{u,j}^{(2)} \in E$  with  $\|Z_{u,j}^{(2)}\| \leq 1$  and  $J'(\zeta_{u,j}u)Z_{u,j}^{(2)} \geq \nu$ . The corresponding part of the proof of Proposition 4.37 then gives (4.52).

Lastly to prepare for 4<sup>o</sup> of Proposition 4.1, recall that for this setting,  $\mathcal{B}(4r, \xi, K)$  does not contain critical points of  $J$ . This leads to:

**Proposition 4.57.** *If  $u \in \mathcal{B}(4r, \xi, K)$  and  $\mathcal{I}_1(u) = \mathcal{I}_2(u) = \emptyset$ , then there exists a constant,  $\bar{\mu}_\xi > 0$  and a  $Z_u^{(3)} \in E$  with  $\|Z_u^{(3)}\| \leq 1$  for which  $J'(u)Z_u^{(3)} \geq \bar{\mu}_\xi$ .*

**Proof:** The proof relies on a more quantitative version of Proposition 2.10. Indeed set

$$R = 6\mathcal{L}(\max_{q \in \mathcal{R}_\xi} \|q\| + 3).$$

Below it will be proved that for any  $u \in \mathcal{B}(4r, \xi, K)$ , we have

$$(4.58) \quad \|u\|_{T_p} < 2\bar{\rho} \text{ for any } p \in \mathbb{Z}^n \text{ such that } \|p\| \geq R.$$

Then via (4.58), Proposition 2.10 can be invoked yielding

$$(4.59) \quad \text{there exists a } \bar{\mu}_\xi > 0 \text{ such that } \|J'(u)\| \geq 2\bar{\mu}_\xi \text{ for any } v \in \mathcal{B}(4r, \xi, K)$$

from which the existence of a  $Z_u^{(3)}$  as in Proposition 4.57 follows.

To verify (4.58), let  $p \in \mathbb{Z}^n$  be such that

$$(4.60) \quad \|p\| \geq R = 6\mathcal{L}(\max_{q \in \mathcal{R}_\xi} \|q\| + 3).$$

Property (4.60) implies that

$$(4.61) \quad \text{if } T_p \cap \mathcal{U}_j \neq \emptyset, \text{ then } j \in \{k+1, \dots, M\}.$$

To prove (4.61), arguing indirectly, suppose that  $T_p \cap \mathcal{U}_j \neq \emptyset$  for some  $j \in \{1, \dots, k\}$ . By definition,  $\mathcal{U}_j = Q_{p(\xi^j)}(\mathcal{L}) \cup (\xi^j + [-\mathcal{L}, \mathcal{L}]^n)$  with  $p(\xi^j) \in \text{int}(\mathcal{R}_\xi)$  and  $Q_{p(\xi^j)}(\mathcal{L}) = 6\mathcal{L}p(\xi^j) + [\frac{1}{2} - 3\mathcal{L}, \frac{1}{2} + 3\mathcal{L}]^n$ . Therefore the condition  $T_p \cap \mathcal{U}_j \neq \emptyset$  implies

$$\|p - 6\mathcal{L}p(\xi^j)\| \leq 4\mathcal{L} + 2.$$

Combining this inequality with (4.60) shows

$$\|p(\xi^j)\| \geq \frac{1}{6\mathcal{L}}\|p\| - \frac{4\mathcal{L}+2}{6\mathcal{L}} \geq \frac{1}{6\mathcal{L}}R - 1 \geq \max_{q \in \mathcal{R}_\xi} \|q\| + 2$$

which contradicts that  $p(\xi^j) \in \text{int}(\mathcal{R}_\xi)$ .

Due to (4.61),  $T_p$  intersects at most  $3^n$  different sets  $\mathcal{U}_j$  with  $j \in \{k+1, \dots, M\}$ , i.e. there is a set of  $i_0 \leq 3^n$  indices  $j_1 < \dots < j_{i_0} \in \{k+1, \dots, M\}$  such that  $T_p \subset \cup_{i=1}^{i_0} \mathcal{U}_{j_i}$ . Since  $\|u\|_{\mathcal{U}_j} \leq 4r$  for  $k+1 \leq j \leq M$  and by (3.4),  $4r < \bar{\rho}/3^n$ ,

$$\|u\|_{T_p} \leq \sum_{i=1}^{i_0} \|u\|_{\mathcal{U}_{j_i}} \leq 3^n \cdot 4r < \bar{\rho}$$

and (4.58) follows.

Having obtained (4.58), an indirect argument will be employed to get (4.59). Assume that there exists a sequence  $(v_i) \subset \mathcal{B}(4r, \xi, K)$  such that  $J'(v_i) \rightarrow 0$  as  $i \rightarrow \infty$ . Using (4.58), Proposition 2.10 can be applied and there is a  $U \in \mathcal{B}(4r, \xi, K)$  with  $v_i \rightarrow U$  as  $i \rightarrow \infty$  and  $J'(U) = 0$ . But this contradicts our assumption that there are no critical points of  $J$  in  $\mathcal{B}(4r, \xi, K)$  and (4.59) and Proposition 4.57 follow.

**Remark 4.62.** Proposition 4.57 defines  $Z_u^{(3)}$  for  $u \in \mathcal{B}(4r, \xi, K)$  when  $\mathcal{I}_1(u) = \mathcal{I}_2(u) = \emptyset$ . For the sequel, we extend the definition of  $Z_u^{(3)}$  to the rest of  $\mathcal{B}(4r, \xi, K)$  by setting  $Z_u^{(3)} = 0$  when  $u \in \mathcal{B}(4r, \xi, K)$  and  $\mathcal{I}_1(u) \neq \emptyset$  or  $\mathcal{I}_2(u) \neq \emptyset$ .

Now using the above preliminaries, for each  $u \in \mathcal{B}(4r, \xi, K)$ , a vector  $\mathcal{V}_u$  satisfying properties 1<sup>o</sup>–4<sup>o</sup> of Proposition 4.1 can be constructed. More precisely, for  $u \in \mathcal{B}(4r, \xi, K)$ , define

$$(4.63) \quad \mathcal{V}_u = \frac{1}{2} \sum_{i \in \mathcal{I}_1^{(a)}(u) \cup \mathcal{I}_2^{(a)}(u)} \bar{\zeta}_{u,i} u + \frac{1}{4} \sum_{i \in \mathcal{I}_1^{(b)}(u)} \zeta_{u,i} Z_{u,i}^{(1)} + \frac{1}{4} \sum_{i \in \mathcal{I}_2^{(b)}(u)} \zeta_{u,i} Z_{u,i}^{(2)} + Z_u^{(3)}$$

where  $Z_{u,i}^{(1)}$  is given by Proposition 4.37,  $Z_{u,i}^{(2)}$  by Proposition 4.49 and  $Z_u^{(3)}$  by Proposition 4.57 and Remark 4.62.

To see that  $\mathcal{V}_u$  satisfies 1<sup>o</sup> – 4<sup>o</sup> requires case analyses. For 1<sup>o</sup>, i.e.

$$(4.64) \quad \|\mathcal{V}_u\|_{\mathcal{U}_j} \leq 1 \text{ for any } j = 1, \dots, M,$$

suppose first that  $\mathcal{I}_1(u) = \mathcal{I}_2(u) = \emptyset$ . Then  $\mathcal{V}_u = Z_u^{(3)}$  and, by Proposition 4.57,  $\|Z_u^{(3)}\| \leq 1$ . Next assume that  $\mathcal{I}_1(u) \neq \emptyset$  or  $\mathcal{I}_2(u) \neq \emptyset$  and let  $j \in \{1, \dots, M\}$ . Then by its definition,  $Z_u^{(3)} = 0$  and since  $\text{supp } \zeta_{u,i} \subset \mathcal{U}_i$ ,

$$(4.65) \quad \begin{aligned} \|\mathcal{V}_u\|_{\mathcal{U}_j} \leq \frac{1}{2} & \left\| \sum_{i \in \mathcal{I}_1^{(a)}(u) \cup \mathcal{I}_2^{(a)}(u)} \bar{\zeta}_{u,i} u \right\|_{\mathcal{U}_j} + \frac{1}{4} \sum_{i \in \mathcal{I}_1^{(b)}(u)} \delta_{i,j} \|\zeta_{u,i} Z_{u,i}^{(1)}\|_{\mathcal{U}_j} \\ & + \frac{1}{4} \sum_{i \in \mathcal{I}_2^{(b)}(u)} \delta_{i,j} \|\zeta_{u,i} Z_{u,i}^{(2)}\|_{\mathcal{U}_j} \end{aligned}$$

where  $\delta_{i,j} = 1$  if  $i = j$  and  $\delta_{i,j} = 0$  if  $i \neq j$ .

To estimate the first term on the right in (4.65), note that  $\text{supp } \bar{\zeta}_{u,i} \subset B_{\mathcal{L}_0}(\mathcal{U}_i)$ . Hence by (iv) of Lemma 3.10, there exist at most  $\iota_0 \leq 3^n$  indices,  $i_1, \dots, i_{\iota_0} \in \mathcal{I}_1^{(a)}(u) \cup \mathcal{I}_2^{(a)}(u)$ , such that  $\text{supp } \bar{\zeta}_{u,i_{\iota}} \cap \mathcal{U}_j \neq \emptyset$ . For any such index  $i_{\iota}$ , using (4.31), (4.18), (3.4), (4.8) and (4.9) leads to

$$\|\bar{\zeta}_{u,i_{\iota}} u\|_{\mathcal{U}_j} \leq \|u\|_{\mathcal{U}_j \cap B_{\bar{\Gamma}_{u,i_{\iota}}}(\mathcal{U}_{i_{\iota}})} + \|\bar{\zeta}_{u,i_{\iota}} u\|_{\mathcal{U}_j \cap \mathcal{N}_{u,i_{\iota}}^{ext}} \leq 5r + \sqrt{3/2} \epsilon_0^{1/2} < \bar{\rho}/3^n.$$

Therefore

$$(4.66) \quad \left\| \sum_{i \in \mathcal{I}_1^{(a)}(u) \cup \mathcal{I}_2^{(a)}(u)} \bar{\zeta}_{u,i} u \right\|_{\mathcal{U}_j} = \left\| \sum_{\iota=1}^{\iota_0} \bar{\zeta}_{u,i_{\iota}} u \right\|_{\mathcal{U}_j} \leq \sum_{\iota=1}^{\iota_0} \bar{\rho}/3^n < \bar{\rho} < 1/2.$$

To handle the remaining two terms in the right hand side of (4.65), observe

that, if  $j \in \mathcal{I}_1^{(b)}(u)$  and  $Z = Z_{u,j}^{(1)}$  or  $j \in \mathcal{I}_2^{(b)}(u)$  and  $Z = Z_{u,j}^{(2)}$ , then, by Propositions 4.37 and 4.49,

$$(4.67) \quad \|\zeta_{u,j}Z\|_{\mathcal{U}_j} \leq \sqrt{3}\|Z\|_{\mathcal{U}_j} \leq \sqrt{3}.$$

By definition  $\mathcal{I}_1(u) \cap \mathcal{I}_2(u) = \emptyset$ , so that by (4.67),

$$(4.68) \quad \frac{1}{4} \sum_{i \in \mathcal{I}_1^{(b)}(u)} \delta_{i,j} \|\zeta_{u,i}Z_{u,i}^{(1)}\|_{\mathcal{U}_j} + \frac{1}{4} \sum_{i \in \mathcal{I}_2^{(b)}(u)} \delta_{i,j} \|\zeta_{u,i}Z_{u,i}^{(2)}\|_{\mathcal{U}_j} \leq \frac{\sqrt{3}}{4}.$$

Then, using (4.66) and (4.68) in (4.65) gives

$$\|\mathcal{V}_u\|_{\mathcal{U}_j} \leq \frac{1}{4} + \frac{\sqrt{3}}{4} < 1.$$

Since  $j$  is arbitrary in  $\{1, \dots, M\}$ , (4.64) follows for this case also and  $1^o$  has been established.

Before going on to the proofs of  $2^o$ - $4^o$ , observe that by Proposition 4.19,

$$J'_j(u)\bar{\zeta}_{u,i}u \geq -\epsilon_0 \text{ for } i, j \in \{1, \dots, M\} \text{ such that } \|\|p^i - p^j\|\| \leq 1,$$

and

$$J'_j(u)\bar{\zeta}_{u,i}u = 0 \text{ for } i, j \in \{1, \dots, M\} \text{ such that } \|\|p^i - p^j\|\| \geq 2.$$

In particular, for any  $j \in \{1, \dots, M\}$ , by (iv) of Lemma 3.10,

$$\#\{i \in \{1, \dots, M\} \mid \|\|p^i - p^j\|\| \leq 1\} \leq 3^n.$$

Therefore for any  $\mathcal{I} \subset \mathcal{I}_1^{(a)}(u) \cup \mathcal{I}^{(a)}(u)$  and any  $j \in \{1, \dots, M\}$ , this leads to the lower bound

$$(4.69) \quad J'_j(u) \left( \sum_{i \in \mathcal{I}} \bar{\zeta}_{u,i}u \right) \geq - \sum_{\{i \in \mathcal{I} \mid \|\|p^i - p^j\|\| \leq 1\}} \epsilon_0 \geq -3^n \epsilon_0.$$

Now  $2^o$  can be proved. The first part of  $2^o$  requires us to show that if  $j_0 \in \{1, \dots, k\}$  is such that

$$3r < \|u - f_{\xi^{j_0}}(K)\|_{\mathcal{U}_{j_0}} < 4r \text{ and } |J_{j_0}(u) - \bar{c}| \leq \frac{3}{2}\lambda(r),$$

then  $J'_{j_0}(u)\mathcal{V}_u \geq 2\mu_1$ . By definition,  $j_0 \in \mathcal{I}_1(u)$  so  $j_0 \notin \mathcal{I}_2(u)$  and  $Z_u^3 = 0$ . In particular it follows that

$$(4.70) \quad J'_{j_0}(u)\mathcal{V}_u = \frac{1}{2} \sum_{i \in \mathcal{I}_1^{(a)}(u) \cup \mathcal{I}_2^{(a)}(u)} J'_{j_0}(u)\bar{\zeta}_{u,i}u + \frac{1}{4} \sum_{j \in \mathcal{I}_1^{(b)}(u)} \delta_{j,j_0} J'_{j_0}(u)\zeta_{u,j}Z_{u,j}^{(1)}.$$

There are two subcases to consider: either

$$(c) \quad j_0 \in \mathcal{I}_1^{(a)}(u) \quad \text{or} \quad (d) \quad j_0 \in \mathcal{I}_1^{(b)}(u).$$

If (c) occurs,  $j_0 \in \mathcal{I}_1^{(a)}(u)$  and then  $\delta_{j,j_0} = 0$  for any  $j \in \mathcal{I}_1^{(b)}(u)$ . Thus by (4.70),

$$(4.71) \quad J'_{j_0}(u)\mathcal{V}_u = \frac{1}{2} \sum_{i \in \mathcal{I}_1^{(a)}(u) \cup \mathcal{I}_2^{(a)}(u)} J'_{j_0}(u)\bar{\zeta}_{u,i}u.$$

Observe now that by (4.36),  $J'_{j_0}(u)\bar{\zeta}_{u,j_0}u \geq \frac{1}{10} \min\{r^2, \lambda(r)\}$ . Hence by (4.9), (4.71) and (4.69),

$$(4.72) \quad \begin{aligned} J'_{j_0}(u)\mathcal{V}_u &= \frac{1}{2} J'_{j_0}(u)\bar{\zeta}_{u,j_0}u + \frac{1}{2} J'_{j_0}(u) \left( \sum_{i \neq j_0, i \in \mathcal{I}_1^{(a)}(u) \cup \mathcal{I}_2^{(a)}(u)} \bar{\zeta}_{u,i}u \right) \\ &> \frac{1}{20} \min\{r^2, \lambda(r)\} - \frac{1}{2} 3^n \epsilon_0 > 2\mu_1. \end{aligned}$$

Consider now subcase (d) where  $j_0 \in \mathcal{I}_1^{(b)}(u)$ . Hence by (4.70),

$$(4.73) \quad J'_{j_0}(u)\mathcal{V}_u = \frac{1}{2} \sum_{i \in \mathcal{I}_1^{(a)}(u) \cup \mathcal{I}_2^{(a)}(u)} J'_{j_0}(u)\bar{\zeta}_{u,i}u + \frac{1}{4} J'_{j_0}(u)\zeta_{u,j_0}Z_{u,j_0}^{(1)}.$$

By Proposition 4.37,  $J'_{j_0}(u)\zeta_{u,j_0}Z_{u,j_0}^{(1)} \geq \mu_r/2$ . Thus the use of (4.9), (4.73) and (4.69) shows

$$(4.74) \quad \begin{aligned} J'_{j_0}(u)\mathcal{V}_u &= \frac{1}{2} J'_{j_0}(u) \left( \sum_{i \in \mathcal{I}_1^{(a)}(u) \cup \mathcal{I}_2^{(a)}(u)} \bar{\zeta}_{u,i}u \right) + \frac{1}{4} J'_{j_0}(u)\zeta_{u,j_0}Z_{u,j_0}^{(1)} \\ &\geq -\frac{1}{2} 3^n \epsilon_0 + \frac{1}{8} \mu_r > 2\mu_1. \end{aligned}$$

Combining (4.74) and (4.72) shows  $J'_{j_0}(u)\mathcal{V}_u \geq 2\mu_1$  and the first part of  $2^\circ$  follows.

For the second part of  $2^\circ$ , it must be shown that if  $j_1 \in \{k+1, \dots, M\}$  is such that  $3r \leq \|u\|_{\mathcal{U}_{j_0}} < 4r$ , then  $J'_{j_1}(u)\mathcal{V}_u \geq 2\mu_1$ . Even in this case  $j_1 \in \mathcal{I}_1(u)$  so that  $j_1 \notin \mathcal{I}_2(u)$ ,  $Z_u^3 = 0$  and

$$(4.75) \quad J'_{j_1}(u)\mathcal{V}_u = \frac{1}{2} \sum_{i \in \mathcal{I}_1^{(a)}(u) \cup \mathcal{I}_2^{(a)}(u)} J'_{j_1}(u)\bar{\zeta}_{u,i}u + \frac{1}{4} \sum_{j \in \mathcal{I}_1^{(b)}(u)} \delta_{j,j_1} J'_{j_1}(u)\zeta_{u,j}Z_{u,j}^{(1)}.$$

Since  $j_1 \geq k+1$ , by (4.35),  $j_1 \in \mathcal{I}_1^{(a)}(u)$ . Therefore  $\delta_{j,j_1} = 0$  for any  $j \in \mathcal{I}_1^{(b)}(u)$  and by (4.36),  $J'_{j_1}(u)\bar{\zeta}_{u,j_1}u \geq \frac{1}{10} \min\{r^2, \lambda(r)\}$ . Thus using (4.9), (4.75) and (4.69) shows,

$$(4.76) \quad \begin{aligned} J'_{j_1}(u)\mathcal{V}_u &= \frac{1}{2} J'_{j_1}(u)\bar{\zeta}_{u,j_1}u + \frac{1}{2} J'_{j_1}(u) \left( \sum_{i \neq j_1, i \in \mathcal{I}_1^{(a)}(u) \cup \mathcal{I}_2^{(a)}(u)} \bar{\zeta}_{u,i}u \right) \\ &> \frac{1}{20} \min\{r^2, \lambda(r)\} - \frac{1}{2} 3^n \epsilon_1 > 2\mu_1. \end{aligned}$$

This gives the second part of  $2^\circ$ .

The proof of  $3^\circ$  involves similar arguments. Suppose that  $u \in \mathcal{B}(4r, \xi, K)$ . The first part of ( $3^\circ$ ) states that if

$$J_{j_0}(u) - \bar{c} \in (\lambda_- - 2\lambda_0, \lambda_- + 2\lambda_0) \cup (\lambda_+ - 2\lambda_0, \lambda_+ + 2\lambda_0)$$

for some  $j_0 \in \{1, \dots, k\}$ , then  $J'_{j_0}(u)\mathcal{V}_u \geq 2\mu_2$ . In this case  $j_0 \in \mathcal{I}_1(u) \cup \mathcal{I}_2(u)$ . Then  $Z_u^3 = 0$  and

$$(4.77) \quad \begin{aligned} J'_{j_0}(u)\mathcal{V}_u &= \frac{1}{2} \sum_{i \in \mathcal{I}_1^{(a)}(u) \cup \mathcal{I}_2^{(a)}(u)} J'_{j_0}(u)\bar{\zeta}_{u,i}u + \frac{1}{4} \sum_{j \in \mathcal{I}_1^{(b)}(u)} \delta_{j,j_0} J'_{j_0}(u)\zeta_{u,j}Z_{u,j}^{(1)} \\ &\quad + \frac{1}{4} \sum_{j \in \mathcal{I}_2^{(b)}(u)} \delta_{j,j_0} J'_{j_0}(u)\zeta_{u,j}Z_{u,j}^{(2)}. \end{aligned}$$

If  $j_0 \in \mathcal{I}_1(u)$ , then  $\delta_{j,j_0} = 0$  for any  $j \in \mathcal{I}_2^{(b)}(u)$  and (4.77) reduces to (4.70). The argument used for  $2^\circ$  then applies unchanged to show

$$(4.78) \quad J'_{j_0}(u)\mathcal{V}_u > 2\mu_1.$$

If  $j_0 \in \mathcal{I}_2(u)$ , then  $\delta_{j,j_0} = 0$  for any  $j \in \mathcal{I}_1^{(b)}(u)$  and

$$(4.79) \quad J'_{j_0}(u)\mathcal{V}_u = \frac{1}{2} \sum_{i \in \mathcal{I}_1^{(a)}(u) \cup \mathcal{I}_2^{(a)}(u)} J'_{j_0}(u)\bar{\zeta}_{u,i}u + \frac{1}{4} \sum_{j \in \mathcal{I}_2^{(b)}(u)} \delta_{j,j_0} J'_{j_0}(u)\zeta_{u,j}Z_{u,j}^{(2)}.$$

Again two subcases must be considered:

$$(e) j_0 \in \mathcal{I}_2^{(a)}(u) \quad \text{or} \quad (f) j_0 \in \mathcal{I}_2^{(b)}(u).$$

If (e) occurs,  $j_0 \in \mathcal{I}_2^{(a)}(u)$  and  $\delta_{j,j_0} = 0$  for any  $j \in \mathcal{I}_2^{(b)}(u)$ . Moreover, by (4.48),  $J'_{j_0}(u)\bar{\zeta}_{u,j_0}u > \frac{1}{10} \min\{r^2, \lambda_0\}$  so using (4.9), (4.79) and (4.69) leads to

$$(4.80) \quad \begin{aligned} J'_{j_0}(u)\mathcal{V}_u &= \frac{1}{2}J'_{j_0}(u)\bar{\zeta}_{u,j_0}u + \frac{1}{2}J'_{j_0}(u)\left(\sum_{i \in \mathcal{I}_1^{(a)}(u) \cup \mathcal{I}_2^{(a)}(u) \setminus \{j_0\}} \bar{\zeta}_{u,i}u\right) \\ &\geq \frac{1}{20} \min\{r^2, \lambda_0\} - \frac{1}{2}3^n \epsilon_0 > 2\bar{\mu}_2. \end{aligned}$$

If (f) occurs,  $j_0 \in \mathcal{I}_2^{(b)}(u)$ , so by Proposition 4.52,  $J'_{j_0}(u)\zeta_{u,j_0}Z_{u,j_0}^{(2)} \geq \nu/2$  and the use of (4.9), (4.79) and (4.69) gives

$$(4.81) \quad \begin{aligned} J'_{j_0}(u)\mathcal{V}_u &= \frac{1}{2}J'_{j_0}(u)\left(\sum_{i \in \mathcal{I}_1^{(a)}(u) \cup \mathcal{I}_2^{(a)}(u)} \bar{\zeta}_{u,i}u\right) + \frac{1}{4}J'_{j_0}(u)\zeta_{u,j_0}Z_{u,j_0}^{(1)} \\ &\geq -\frac{1}{2}3^n \epsilon_0 + \frac{1}{8}\nu > 2\bar{\mu}_2. \end{aligned}$$

Combining (4.78), (4.80) and (4.81) yields the first part of  $3^\circ$  with  $\mu_2 = \min\{\mu_1, \bar{\mu}_2\}$ .

To complete the proof of  $3^\circ$ , assume that  $j_1 \in \{k+1, \dots, M\}$  is such that  $\lambda_+ - 2\lambda_0 \leq J_{j_1}(u) \leq \lambda_+ + 2\lambda_0$ . To be shown is that  $J'_{j_1}(u)\mathcal{V}_u \geq 2\mu_2$ . Again if  $j_1 \in \mathcal{I}_1(u)$ , the same argument used to obtain  $2^\circ$  proves

$$(4.82) \quad J'_{j_1}(u)\mathcal{V}_u > 2\mu_1.$$

If  $j_1 \in \mathcal{I}_2(u)$ , then  $Z_u^3 = 0$  and since  $j_1 \geq k+1$ , (4.47) implies  $j_1 \in \mathcal{I}_2^{(a)}(u)$ . Hence by (4.48),  $J'_{j_1}(u)\bar{\zeta}_{u,j_1}u \geq \frac{1}{10} \min\{r^2, \lambda(r)\}$  and as for (4.80),

$$(4.83) \quad J'_{j_1}(u)\mathcal{V}_u > \frac{1}{20} \min\{r^2, \lambda(r)\} - \frac{1}{2}3^n \epsilon_0 > 2\mu_2.$$

The second part of ( $3^\circ$ ) follows from (4.82) and (4.83) with  $\mu_2 = \min\{\mu_1, \bar{\mu}_2\}$ .

Lastly ( $4^\circ$ ) will be proved. To do so, note first that by (4.8), (4.9), (4.36) and (4.48),

$$(4.84) \quad J'(u)\bar{\zeta}_{u,j}u > 4\mu_1 \text{ if } j \in \mathcal{I}_1^{(a)} \text{ and } J'(u)\bar{\zeta}_{u,j}u > 4\mu_2 \text{ if } j \in \mathcal{I}_2^{(a)}$$

Moreover, since  $\text{supp}(\zeta_{u,j}) \subset \mathcal{U}_j$  for any  $j \in \mathcal{I}_1^b \cup \mathcal{I}_2^{(b)}$ , by (4.8), (4.9) and Propositions 4.37 and 4.49 we have,

$$(4.85) \quad J'(u)\zeta_{u,j}Z_j^{(1)} = J'_j(u)\zeta_{u,j}Z_j^{(1)} > 8\mu_1 \text{ if } j \in \mathcal{I}_1^{(b)} \text{ and}$$

$$(4.86) \quad J'(u)\zeta_{u,j}Z_j^{(2)} = J'_j(u)\zeta_{u,j}Z_j^{(2)} > 8\mu_2 \text{ if } j \in \mathcal{I}_2^{(b)}.$$

Hence (4.63), (4.84), (4.85), (4.86) imply that if  $\mathcal{I}_1(u) \cup \mathcal{I}_2(u) \neq \emptyset$ , for the case in which  $Z_u^{(3)} = 0$  we have

$$(4.87) \quad J'(u)\mathcal{V}_u = \frac{1}{2} \sum_{i \in \mathcal{I}_1^{(a)}(u) \cup \mathcal{I}_2^{(a)}(u)} J'(u)\bar{\zeta}_{u,i}u + \frac{1}{4} \sum_{i \in \mathcal{I}_1^{(b)}(u)} J'(u)\zeta_{u,i}Z_{u,i}^{(1)} \\ + \frac{1}{4} \sum_{i \in \mathcal{I}_2^{(b)}(u)} J'(u)\zeta_{u,i}Z_{u,i}^{(2)} \geq \min\{2\mu_1, 2\mu_2\}.$$

If  $\mathcal{I}_1(u) = \emptyset$  and  $\mathcal{I}_2(u) = \emptyset$ , then  $\mathcal{V}_u = Z_u^{(3)}$  and for this case, Proposition 4.57 gives

$$(4.88) \quad J'(u)\mathcal{V}_u = J'(u)Z_u^{(0)} \geq 2\bar{\mu}_\xi.$$

Combining (4.87) and (4.88), (4<sup>o</sup>) follows with  $\mu_\xi = \min\{\bar{\mu}_\xi, \mu_1, \mu_2\}$  and Proposition 4.1 is proved.

## References

- [1] S. Angenent, *The shadowing lemma for elliptic pde, Dynamics of infinite dimensional systems*, (Berlin Heidelberg New York) (S. Chow and J. Hale, eds.), NATO ASI, vol. F37, Springer- Verlag, 1987, pp. 7–22.
- [2] S. Alama, Y.Y. Li, *On "Multibump" Bound States for Certain Semilinear Elliptic Equations*, Indiana J. Math., **41**, , 983–1026, (1992).
- [3] F. Alessio, P. Caldiroli, P. Montecchiari, *Genericity of the existence of infinitely many solutions for a class of semilinear elliptic equations in  $\mathbb{R}^N$* , Ann. Sc. Norm. Super. Pisa, Cl. Sci., IV. Ser. 27, No.1, 47-68 (1998).
- [4] J. Byeon, P. Montecchiari & P.H. Rabinowitz, *A double well potential System*, Analysis & PDE, Vol. 9, No. 7, 1737–1772, (2016).

- [5] S. Bolotin & P.H. Rabinowitz, *A note on hybrid heteroclinic solutions for a class of semilinear elliptic PDEs*, Atti Accad. Naz. Lincei Cl. Sci. Fis. Mat. Natur. Rend. Lincei (9) Mat. Appl. **22** 151–160 (2011) .
- [6] S. Bolotin & P.H. Rabinowitz, *Hybrid mountain pass homoclinic solutions of a class of semilinear elliptic PDEs* Ann. I. H. Poincaré AN **31** 103–128 (2014)
- [7] P. Caldiroli, P. Montecchiari, *Homoclinic orbits for second order Hamiltonian systems with potential changing sign*, Commun. Appl. Nonlinear Anal. 1, No.2, 97-129 (1994).
- [8] K. Cieliebak and E. Séré, *Pseudoholomorphic curves and the shadowing lemma*, Duke Math. J **99**, 41-73 (1999).
- [9] C. V. Coffman, *A minimum-maximum principle for a class of integral equations*, J. Analyse Math.,**22**, 391-419 (1969).
- [10] V. Coti Zelati & P.H. Rabinowitz, *Homoclinic orbits for second order hamiltonian systems possessing superquadratic potentials*, J. Amer. Math. Soc., **4**, 693-727, (1991).
- [11] V. Coti Zelati and P.H. Rabinowitz, *Homoclinic type solutions for a semilinear elliptic PDE on  $\mathbf{R}^n$* , Comm. Pure Appl. Math., **45**, 1217-1269, (1992),.
- [12] V. Coti Zelati and P.H. Rabinowitz, *Multibump periodic solutions of a family of Hamiltonian systems*, Top. Meth. in Nonlin. Analysis, **4**, 31-57, (1994).
- [13] Gilbarg, D. and Trudinger, N. S., *Elliptic Partial Differential Equations of Second Order*, 2nd ed., Springer-Verlag, 1983.
- [14] J. A. Hempel, *Superlinear variational boundary value problems and nonuniqueness*, thesis, University of New England, Australia, 141 pages, 1970.
- [15] Jeanjean,L. and Tanaka, K., *A remark on least energy solutions in  $R^N$* , Proceedings of the American Mathematical Society, **131(8)**2399-2408, (2003).

- [16] C. Miranda, *Un'osservazione su un teorema di Brouwer*, Boll. Unione Mat. Ital.,**3**, 5-7, (1940).
- [17] P. Montecchiari, *Existence and multiplicity of homoclinic solutions for a class of asymptotically periodic second order Hamiltonian systems*, Ann. Mat. Pura ed App., **CLXVIII**, 317-354, (1995).
- [18] P. Montecchiari, *Multiplicity results for a class of Semilinear Elliptic Equations on  $\mathbb{R}^m$* , Rend. Sem. Mat. Univ. Padova, **95**, 1-36, (1996).
- [19] P. Montecchiari, M. Nolasco, S. Terracini, *Multiplicity of homoclinics for a class of time recurrent second order Hamiltonian systems*, Calc. Var. Partial Differ. Equ. 5, No.6, 523-555 (1997).
- [20] P. Montecchiari, M. Nolasco, S. Terracini, *A global condition for periodic Duffing-like equations*, Trans. Am. Math. Soc. 351, No.9, 3713-3724 (1999).
- [21] P. Montecchiari and P. H. Rabinowitz, *On the existence of multi-transition solutions for a class of elliptic systems*, Ann. Inst. H. Poincaré Anal. Non Linéaire, **33**, 199–219, (2016).
- [22] P. Montecchiari and P. H. Rabinowitz, *Solutions of mountain pass type for double well potential systems*, Calc. Var. PDE (2018) 57: 114. <https://doi.org/10.1007/s00526-018-1400-4>.
- [23] P. Montecchiari and P. H. Rabinowitz, *On global non-degeneracy conditions for chaotic behavior for a class of dynamical systems*, Ann. Inst. H. Poincaré Anal. Non Linéaire, **36**, 3, 627–653 (2019) <https://doi.org/10.1016/j.anihpc.2018.08.002>.
- [24] P. Montecchiari and P. H. Rabinowitz, *A nondegeneracy condition for a semilinear elliptic system and the existence of 1- bump solutions* Discrete and Continuous Dynamical Systems - A, 39, (12) 6995-7012 (2019).
- [25] Z. Nehari, *On a class of nonlinear second order differential equations*, Trans. A.M.S., **95**, 101-123, (1960).
- [26] P. H. Rabinowitz, *Minimax Methods in Critical Point Theory with Applications to Differential Equations*, CBMS Regional Conference Series in Mathematics , **65**, Amer. Math. Soc., Providence, R.I., (1986).

- [27] P. H. Rabinowitz, *Homoclinic orbits for a class of Hamiltonian systems*, Proc. Roy. Soc. Edinburgh Sect. A **114**, 33–38 (1990).
- [28] P. H. Rabinowitz, *On a class of nonlinear Schrödinger equations*, ZAMP, **43**, 270-291, (1992).
- [29] P. H. Rabinowitz, *A note on a semilinear elliptic equation on  $\mathbb{R}^n$* , in *Nonlinear Analysis, A tribute in honour of G. Prodi*. Quaderni Scuola Normale Superiore, Pisa, A. Ambrosetti and A. Marino, editors, 307-317, (1991).
- [30] P. H. Rabinowitz, *A multibump construction in a degenerate setting*, Calc. Var. Partial Differential Equations **5**, 15–182 (1997).
- [31] E. Séré, *Existence of infinitely many homoclinic orbits in Hamiltonian systems*, Math. Z. , **209**, 27–42, (1992).
- [32] E. Séré *Looking for the Bernoulli shift* Ann. Inst. H. Poincaré. Anal. Non Linéaire, **10**, 561-590, (1993).
- [33] G. S. Spradlin, *Multibump solutions to a class of semilinear partial differential equations*, University of Wisconsin thesis, 138 pages,(1995).